

PLANETENGETRIEBE PS

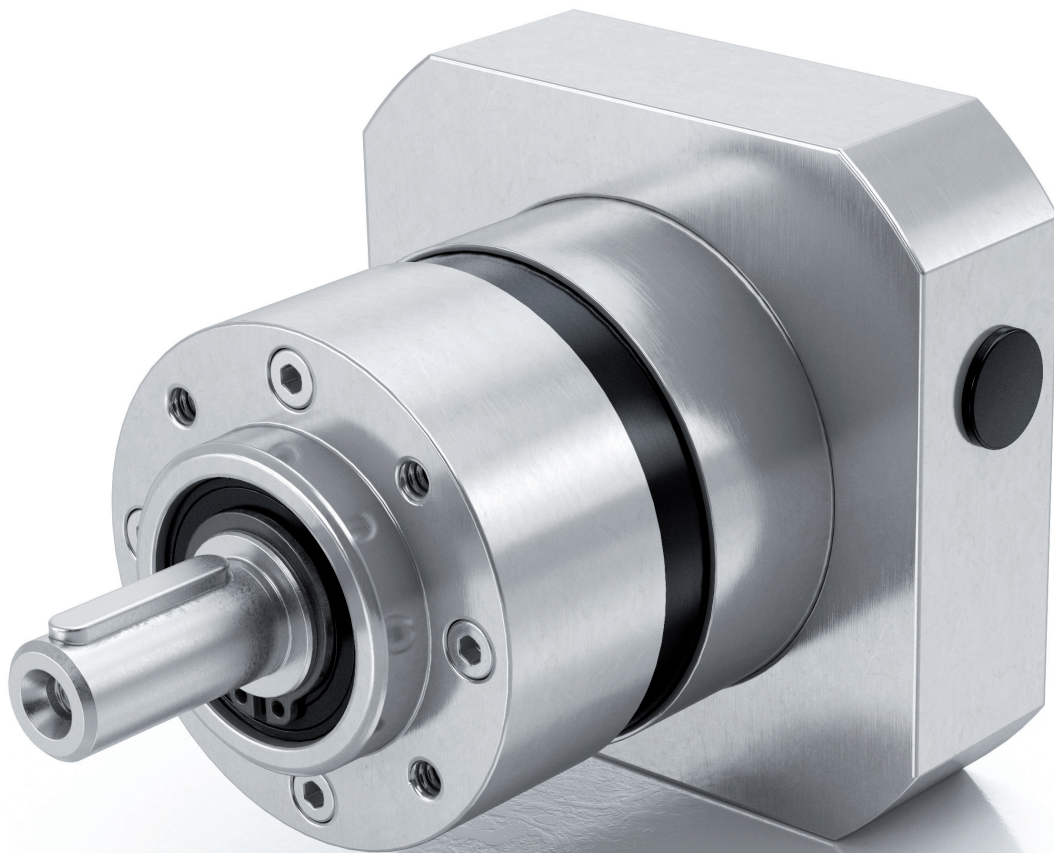

**success based on
quality and reliability**

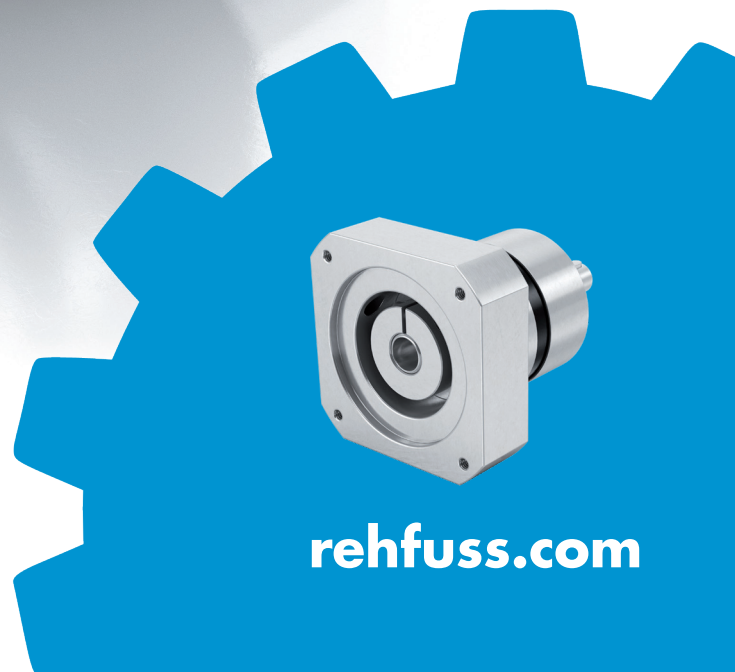

rehfuss.com

Technische Daten

T2N = Nenn-Abtriebsmoment, T2B = max. Beschleunigungsmoment 1000x/h, T2S = Not-Aus Moment (max. 1000x), J = Massenträgheitsmoment, VS = Verdrehsteifigkeit

1-stufig		PS104Z					PS106Z					PS108Z					PS110Z					PS130Z				
Unter- setzung i	T2N	T2B	T2S	J	VS	T2N	T2B	T2S	J	VS	T2N	T2B	T2S	J	VS	T2N	T2B	T2S	J	VS	T2N	T2B	T2S	J	VS	
	Nm	Nm	Nm	kgcm ²	Nm/arcmin	Nm	Nm	Nm	kgcm ²	Nm/arcmin	Nm	Nm	Nm	kgcm ²	Nm/arcmin	Nm	Nm	Nm	kgcm ²	Nm/arcmin	Nm	Nm	Nm	kgcm ²	Nm/arcmin	
3	5,0	10	20	0,06	0,85	30	45	72	0,45	2,4	88	120	180	1,37	7,1	150	260	350	6,54	17	405	490	860	12,3	33	
4	8,5	13	26	0,04	0,85	40	62	84	0,38	2,4	120	130	216	1,14	7,1	230	300	480	4,80	17	480	500	1000	7,65	33	
5	7,5	13	26	0,04	0,85	35	56	84	0,36	2,4	110	110	216	1,05	7,1	200	275	480	4,05	17	440	460	1000	6,24	33	
7	7	13	26	0,04	0,65	26	44	84	0,35	1,7	66	85	216	0,97	4,8	120	200	480	3,40	14	310	460	1000	4,70	27	
8	7,5	9	22	0,04	0,65	19	26	80	0,35	1,7	53	68	180	0,97	4,8	152	175	390	3,40	14	390	440	900	4,70	27	
10	10	13	20	0,04	0,45	16	24	62	0,34	1,3	40	75	160	0,93	3,4	105	180	410	3,10	8,3	180	340	800	3,80	22	
Verdrehspiel [arcmin]		< 15					< 10					< 7					< 7					< 7				
Gewicht ca. [kg]		0,4					0,9					2,2					5,6					10,3				
Wirkungsgrad [%] bei Vollast		94																								

2-stufig		PS204Z					PS206Z					PS208Z					PS210Z					PS230Z				
Unter- setzung i	T2N	T2B	T2S	J	VS	T2N	T2B	T2S	J	VS	T2N	T2B	T2S	J	VS	T2N	T2B	T2S	J	VS	T2N	T2B	T2S	J	VS	
	Nm	Nm	Nm	kgcm ²	Nm/arcmin	Nm	Nm	Nm	kgcm ²	Nm/arcmin	Nm	Nm	Nm	kgcm ²	Nm/arcmin	Nm	Nm	Nm	kgcm ²	Nm/arcmin	Nm	Nm	Nm	kgcm ²	Nm/arcmin	
9	10	12,5	20	0,04	0,85	35	52	72	0,38	2,4	105	140	160	1,14	7,1	210	260	400	4,80	17	450	500	860	12,3	33	
12	10	12,5	20	0,04	0,85	43	57	72	0,38	2,4	110	160	160	1,14	7,1	260	310	500	4,80	17	500	500	1000	12,3	33	
15	10	12,5	20	0,04	0,85	44	55	84	0,38	2,4	118	150	216	1,14	7,1	230	350	400	4,80	17	470	460	1000	7,65	33	
16	14	17,5	26	0,04	0,85	52	71	84	0,38	2,4	139	163	216	1,14	7,1	320	380	500	4,80	17	500	500	1000	7,65	33	
20	14	17,5	26	0,04	0,85	52	71	84	0,36	2,4	139	163	216	1,05	7,1	320	380	500	4,80	17	500	500	1000	6,24	33	
25	12	14	26	0,04	0,85	47	62	84	0,36	2,4	118	138	216	1,05	7,1	260	350	500	4,80	17	460	460	1000	6,25	33	
32	13	18	26	0,04	0,85	52	71	84	0,35	2,4	139	163	216	1,05	7,1	320	380	500	4,80	17	500	500	1000	4,70	33	
35	12	14	26	0,04	0,85	44	62	84	0,35	2,4	118	138	216	0,97	7,1	260	350	480	3,40	17	460	460	1000	4,70	33	
40	14	17,5	26	0,04	0,85	42	71	84	0,34	2,4	139	163	216	0,93	7,1	320	380	480	4,80	17	500	500	1000	3,80	33	
50	12	14	26	0,04	0,85	44	62	84	0,34	2,4	118	138	216	0,93	7,1	260	350	480	4,80	17	460	460	1000	3,80	33	
64	10	14	27	0,04	0,85	21	29	80	0,34	2,4	66	75	180	0,93	7,1	155	175	390	4,80	17	420	480	900	3,80	27	
70	14	17,5	26	0,04	0,85	42	52	84	0,34	1,7	100	125	216	0,93	4,8	210	255	480	4,80	14	340	460	1000	3,80	27	
80	20	24	27	0,04	0,85	21	30	80	0,34	1,7	65	75	180	0,93	4,8	155	175	390	4,80	14	420	480	900	3,80	27	
100	17	24	20	0,04	0,45	18	28	62	0,34	1,3	64	80	160	0,93	3,4	165	180	410	4,80	8,3	190	340	800	3,80	22	
Verdrehspiel [arcmin]		< 19					< 12					< 9					< 9					< 10				
Gewicht ca. [kg]		0,5					1,2					3,0					7,7					12,8				
Wirkungsgrad [%] bei Vollast		92																								

Radialkraft / Axialkraft [N] bei n2 = 100 1/min, Lh Lager > 10.000 St.										
400 / 300		450 / 550		800 / 1200		1600 / 2000		6500 / 7500		
Schallemission [dbA] bei n1= 3000 1/min, Messpunkt 1m Abstand, ohne Last										
< 62		< 62		< 64		< 67		< 70		
Nenn-Eingangsdrehzahl / max. Eingangsdrehzahl [1/min] – zulässige Betriebstemperatur darf nicht überschritten werden										
3500 / 6000		3500 / 6000		3000 / 6000		2500 / 5000		2500 / 4500		
Lebensdauer [h]										
> 30.000										
Schmierung										
Lebensdauerschmierung										
Schutzart										
IP54										
Einbaulage										
beliebig										
Zul. Betriebstemperatur										
-20°C bis +90°C										

Maße (in mm):

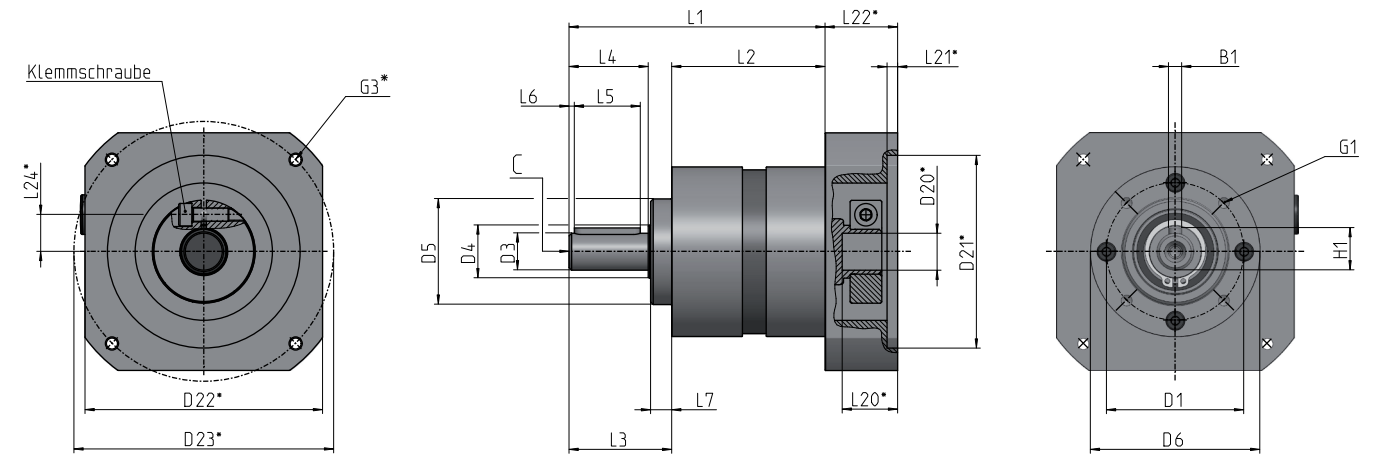

Getriebetyp	PS104Z	PS204Z	PS106Z	PS206Z	PS108Z	PS208Z	PS110Z	PS210Z	PS130Z	PS230Z														
	1-stufig	2-stufig	1-stufig	2-stufig	1-stufig	2-stufig	1-stufig	2-stufig	1-stufig	2-stufig														
D1	Lochkreis Ø		34		52		70		100		145													
D3 _{h7}	Abtriebswelle Ø		10		14		20		25		40													
D4	Wellenbund Ø		12		17		25		35		50													
D5 _{h7}	Zentrierung Ø		26		40		60		80		130													
D6	Gehäuse Ø		40		60		80		115		160													
G1	Gewinde / Tiefe (4x)		M4/6,5		M5/12		M6/14		M10/16		M12/22													
C	Zentriergewinde / Tiefe		M3/9		M5/12		M6/16		M10/22		M16/36													
L1	Länge ohne Antriebsflansch		75,7		91,3		98,2		120,3		113,5		138		155,1		187,1		248,5		290			
L2	Gehäuselänge		49,7		65,3		63,3		85,4		73,5		98		100,1		132,1		161,5		203			
L3	Einbaumaß		26		35		40		55		87													
L4	Wellenlänge		23		30		36		50		80													
L7	Zentrierbundlänge		2		4		3		4		5													
L5	Länge Passfeder		18		25		28		40		65													
L6	Lage Passfeder		2,5		2		4,5		5		8													
B1	Passfederbreite		3		5		6		8		12													
H1	Höhe über Passfeder		11,2		16		22,5		28		43													
Antriebsflansch / Motorwelle																								
Stand. Bohrung Spannsystem			11		14		19		24		32													
Max. Bohrung Spannsystem			14		19		24		35		38													
D20*	Durchmesser Bohrung Antrieb																							
D21 ^{G7*}	Durchmesser Innenzentrierung																							
D22*	□- Antriebsflansch																							
D23*	Lochkreis Gewinde Antriebsfl.																							
L20*	Länge Durchmesser Antrieb																							
L21*	Länge Innenzentrierung																							
L22*	Länge Antriebsflansch																							
L24*	Lage Klemmschraube																							
G3*	Anschraubgewinde																							

*Motorspezifische Flansch- und Motorwellen-Geometrien. Für Motorwellen ohne Paßfeder. Maße variieren.

Bestellschlüssel:

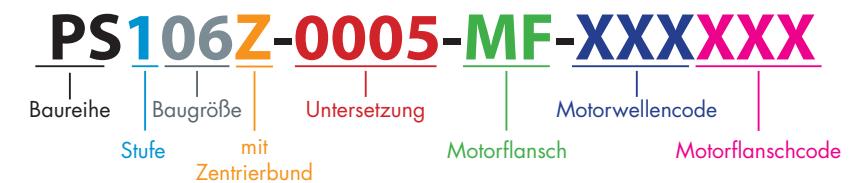

Highlights

HOHER WIRKUNGSGRAD

BELIEBIGE EINBAULAGE

SCHUTZART IP54

HOHE
VERDREHSTEIFIGKEIT

GANZZAHLIGE
UNTERSETZUNGEN

LEBENSDAUERSCHMIERUNG

KOMPAKTE BAUFORM

GERINGES
VERDREHSPIEL

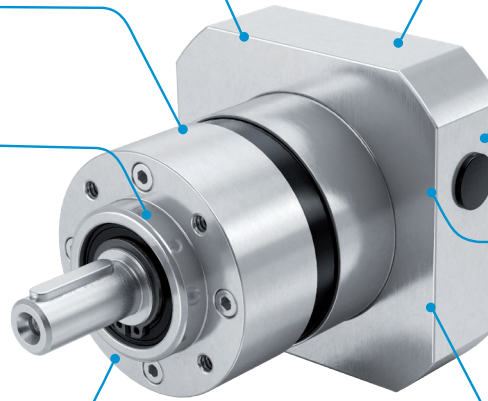

AXIALBELASTUNGSFREIE
MOTOR-DIREKTMONTAGE
MITTELS KLEMMVER-
BINDUNG

MODULARES
WECHSELFLANSCHSYSTEM
mit allen gängigen Servo-
motoren adaptierbar

SICHERES
MOTORSPEZIFISCHES
ANBAUSYSTEM

HOHE EINGANGS-
DREHZAHLEN

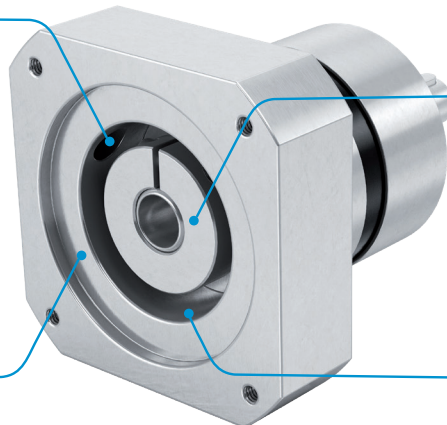

Optionen:

- Kombinierbar mit all unseren Motoren und unterschiedlichsten Motoranbindungen
- Geeignet für Applikationen in nahezu allen Branchen
- Flanschoptionen für Synchron Servomotoren

Eigenschaften:

- Robust und kompakt
- Lebensdauerschmierung
- Gehäuse aus Aluminium
- beliebige Einbaulage

Reh fuss Drive Solutions GmbH

E-Mail: info@rehfuss.com
rehfuss.com

Tel.: +49 7432 7015-0
Fax: +49 7432 7015-90