

BC2 SOLID BEARING RODLESS CYLINDER



CONTENTS

Features	BC2_2
Performance	BC2_4
Carrier Adjustment	BC2_5
BC205	BC2_6
BC210	BC2_8
BC212 & 15	BC2_10
BC220 & 25	BC2_12
Auxiliary Carrier	BC2_14
Tube Supports	BC2_16
Foot Mount	BC2_17
Floating Mount	BC2_18
Switches	BC2_20
Shock Absorbers	BC2_22
Application Data Worksheet	BC2_24
Selection Guidelines	BC2_25
Application Guidelines	BC2_26
Service Parts	BC2_27
Ordering	BC2_28

ART
MXP
BC2
BC3
BC4
LS
MG
CC
PB
ENGR

BC2 BAND CYLINDER

ENDURANCE TECHNOLOGYSM

Endurance Technology features are designed for maximum durability to provide extended service life.

The BC2 is the direct descendent of the industry's first pneumatic rodless cylinder, manufactured by Tolomatic, the number one rodless supplier. Featuring durable stainless steel bands, field replaceable engineered bearings and a large carrier mounting pattern the BC2 is a great solution for applications that require increased Mx bending moment capacity. Built-to-order in stroke lengths up to 350 inches.

FORMED STEEL PISTON BRACKET

- Provides maximum strength at major stress points
- Heat treated carbon steel withstands the toughest dynamic forces
- Strongest bracket design in the industry assures long life with less maintenance

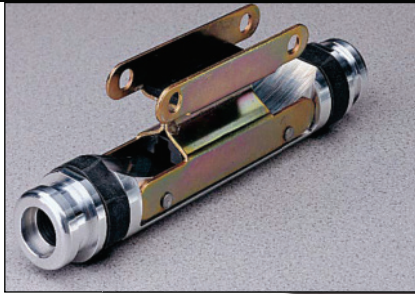

STAINLESS STEEL SEALING BAND SYSTEM

- Fatigue resistant stainless steel bands are specifically made to provide longer life and will not elongate, like elastomers
- Outer band keeps out contaminants for extended performance
- Inner band provides a smooth surface for less seal wear

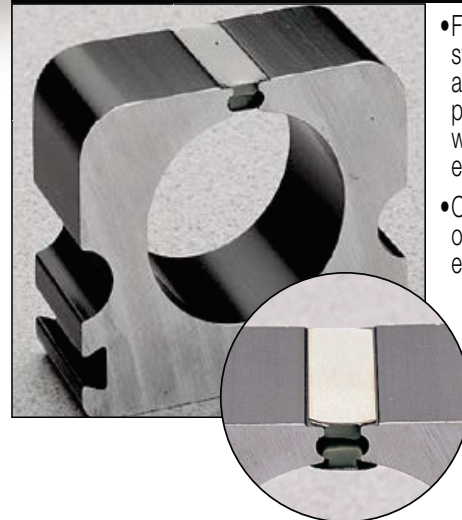

FORMED END CAP WIPER SEAL

- Keeps contaminants from entering the sealing area
- Protects internal components
- Reduces maintenance while increasing productivity

ADJUSTABLE CUSHIONS

- Adjustable cushions are standard, not optional
- Easy screw adjustment for end-of-stroke deceleration
- Protects actuator and load from damage

TOLOMATIC...THE RODLESS CYLINDER LEADER



3-PORTED HEADS

- Standard feature
- Simplifies air connections

RIGID BLACK-ANODIZED EXTRUDED ALUMINUM TUBE

- Stronger, stiffer tube retains tolerance specs when chamber is pressurized
- Keeps sealing band in place for maximized air efficiency
- Tube supports are minimized
- Solid structural support provides durability and long life performance

ADJUSTABLE CARRIER BRACKET



- 2-bolt adjustment instead of a series of set screws
- Easy to set tension for freer running or stiffer systems
- Minimizes free play while maintaining a higher level of load guidance

LOAD-BEARING CARRIER DESIGN

- Load and piston are independent - piston floats, resulting in less friction and longer seal life
- Engineered resin load bearings offer consistently low friction and long wear



OPTIONS



AUXILIARY CARRIER

- Substantially higher load capacity
- Substantially higher bending moment capacity



FLOATING MOUNT

- Compensates for non-parallelism between band cylinder and externally guided load



TUBE SUPPORT MOUNTS

- Used for intermediate support



FOOT MOUNTS

- For end mounting of band cylinder



SHOCK ABSORBERS

- Smooth deceleration
- Allows increased operating speed
- Self-compensates for load or speed changes
- Minimizes impact load to equipment
- Higher equipment productivity
- Adjustable position shocks available



SWITCHES

- Available in Reed, Hall-effect and Triac
- 15ft. cable with flying leads; available with quick-disconnect couplers

BC2 Solid Bearing Rodless Cylinder

PERFORMANCE

BC2 BENDING MOMENTS AND LOAD, ALL SIZES

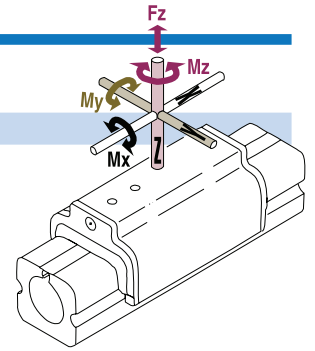

STANDARD ACTUATOR

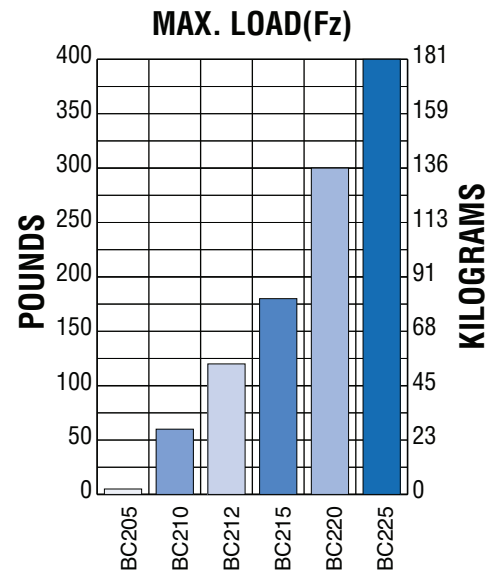
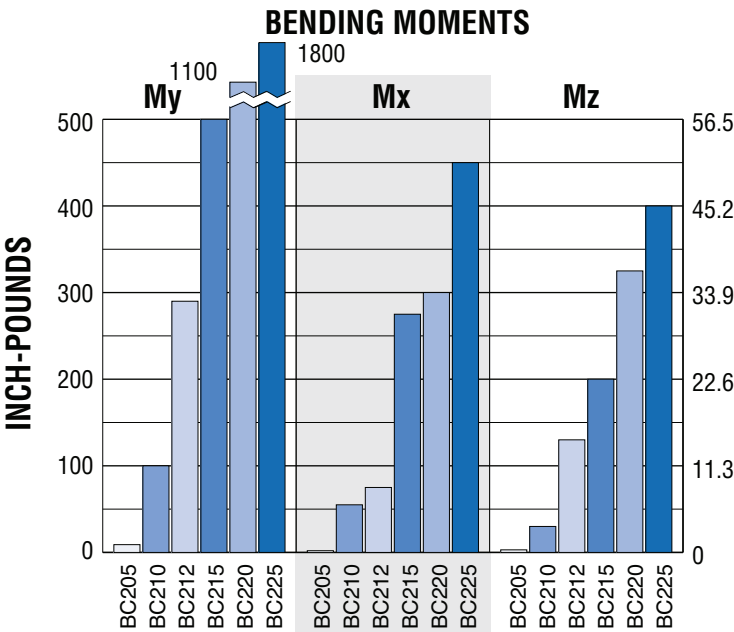

AUXILIARY CARRIER OPTION

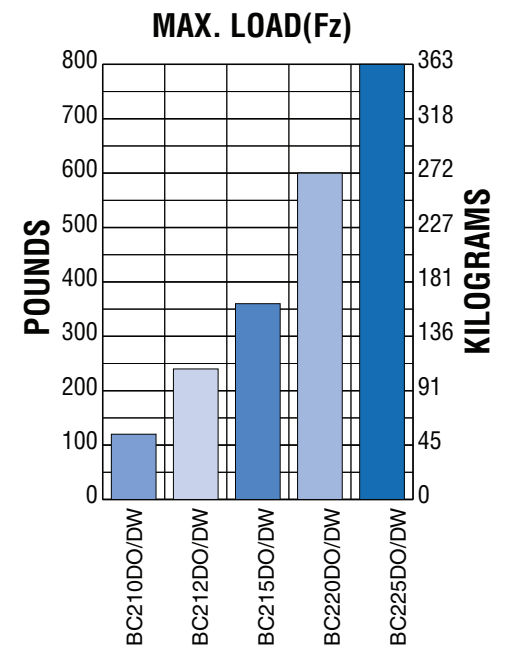
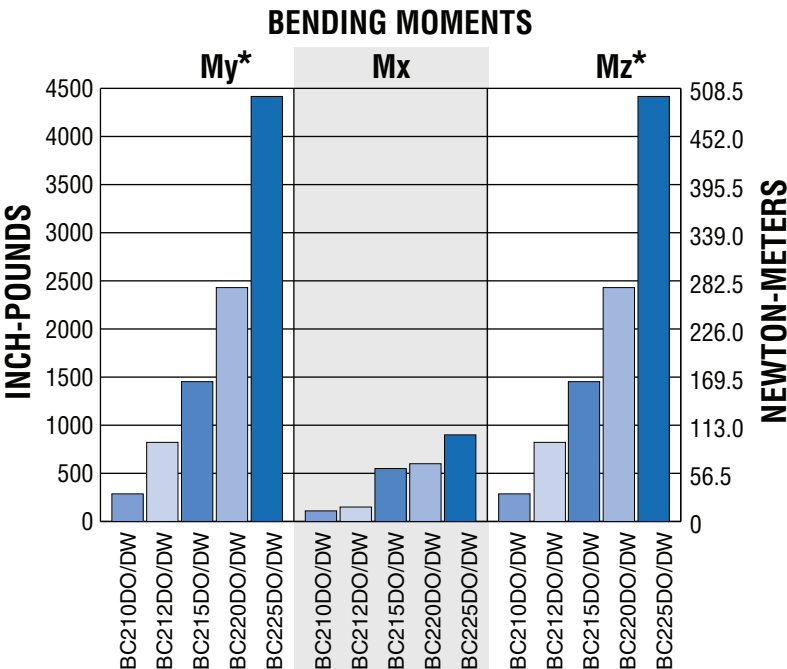

*Auxiliary carrier bending moments indicated are at minimum center to center distance. Additional My + Mz load capacity can be obtained by increasing "D" dimension. Refer to auxiliary carrier data on page BC2_14.

BC2 Solid Bearing Rodless Cylinder

GUIDELINES

BC2 THEORETICAL FORCE vs PRESSURE

BC2 CARRIER BRACKET BOLT ADJUSTMENT

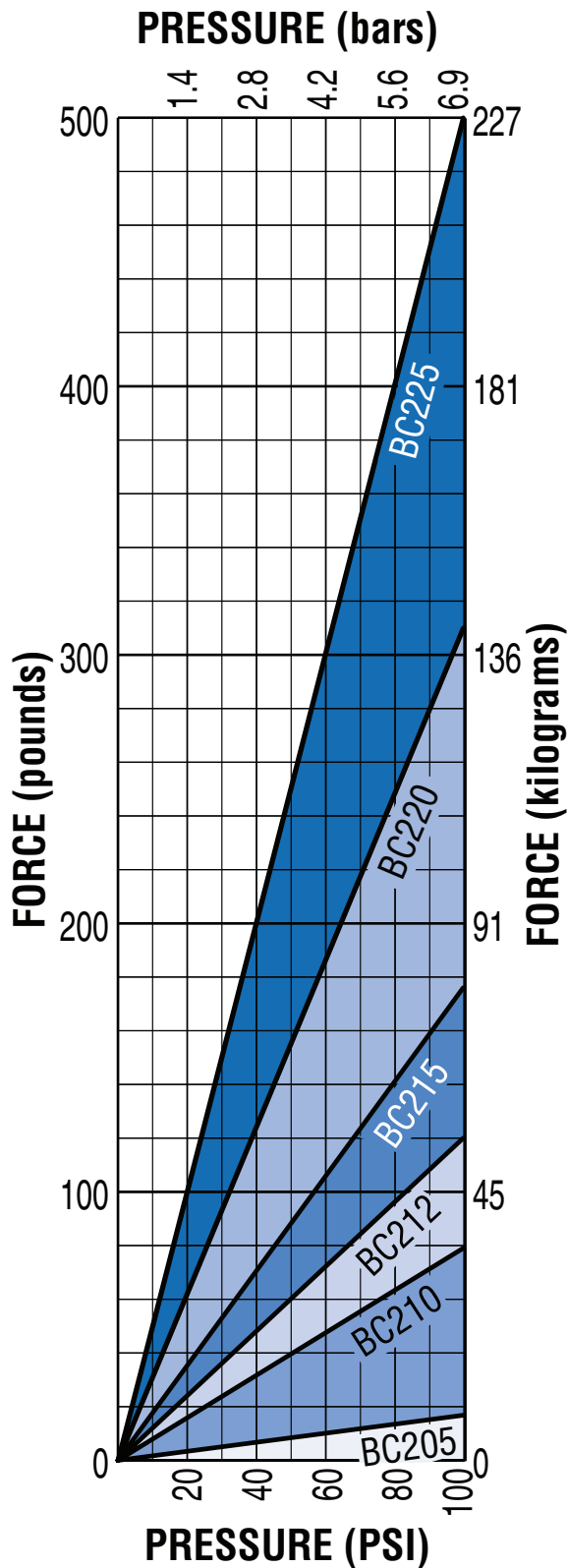

BC2 carrier bracket adjustment bolts should be adjusted to suit each individual application, depending on the degree of rigidity required. A good starting point is to tighten the nut on the bolt until there is no lateral movement of the bolt. Then, equally tighten each nut on the carrier bolt while moving the carrier by hand along the length of the stroke. When all lateral play in the carrier is eliminated and free movement along the length of the stroke is maintained, your carrier bracket is adjusted properly. Some applications may require fine tuning of this adjustment to gain more lateral play or a higher degree of rigidity. In demanding applications, carrier adjustments should be done periodically.

BC205 Solid Bearing Rodless Cylinder

PERFORMANCE

BC205



BC205 OPTIONS	Page
Floating Mount	BC2_18
Foot Mount	BC2_17
Switches	BC2_20
Tube Supports	BC2_16
MORE INFORMATION	Page
Application Guidelines	BC2_26
Ordering	BC2_28
Selection	BC2_25

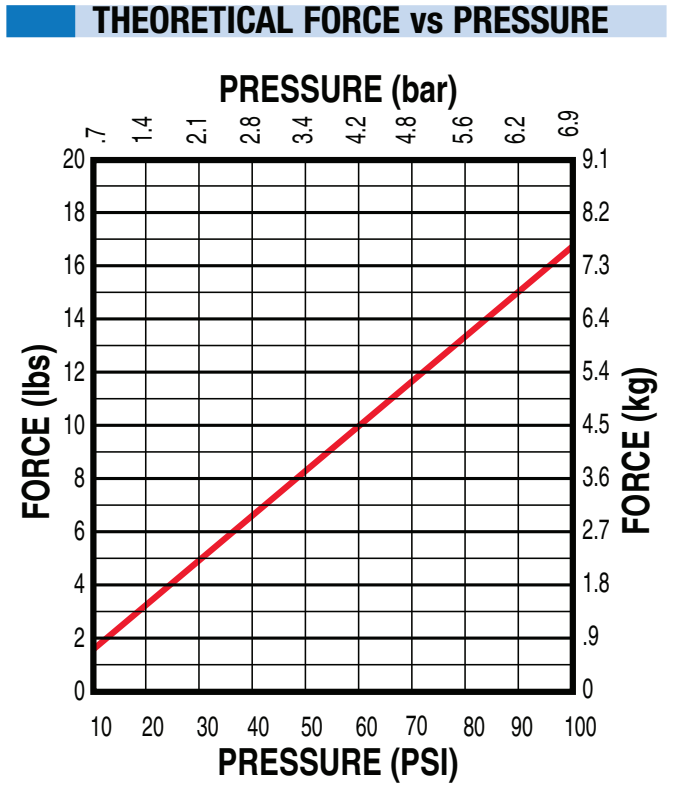

BUMPER DAMPENING

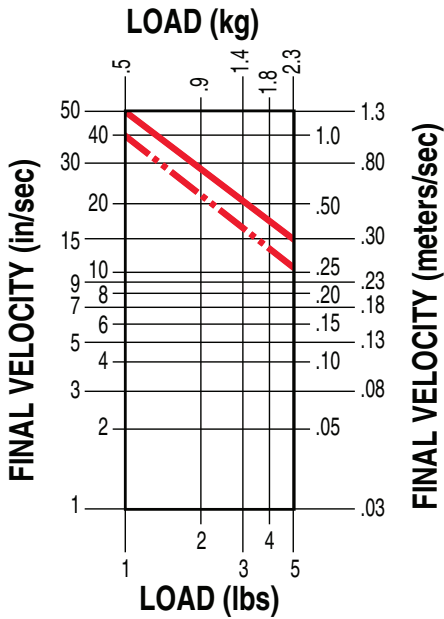

NOTE:
— Max. for any application
- - - Max. for continuously cycled application

TUBE SUPPORT REQUIREMENTS

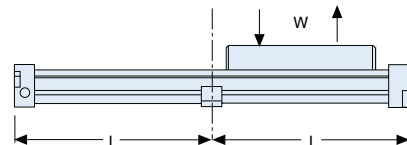
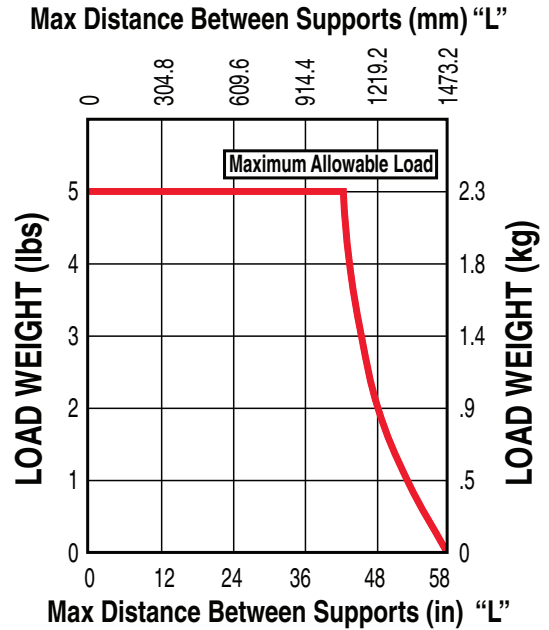

BC205 Solid Bearing Rodless Cylinder

3D CAD available at
www.tolomatic.com



DIMENSIONS

Always use configured CAD solid model to determine critical dimensions

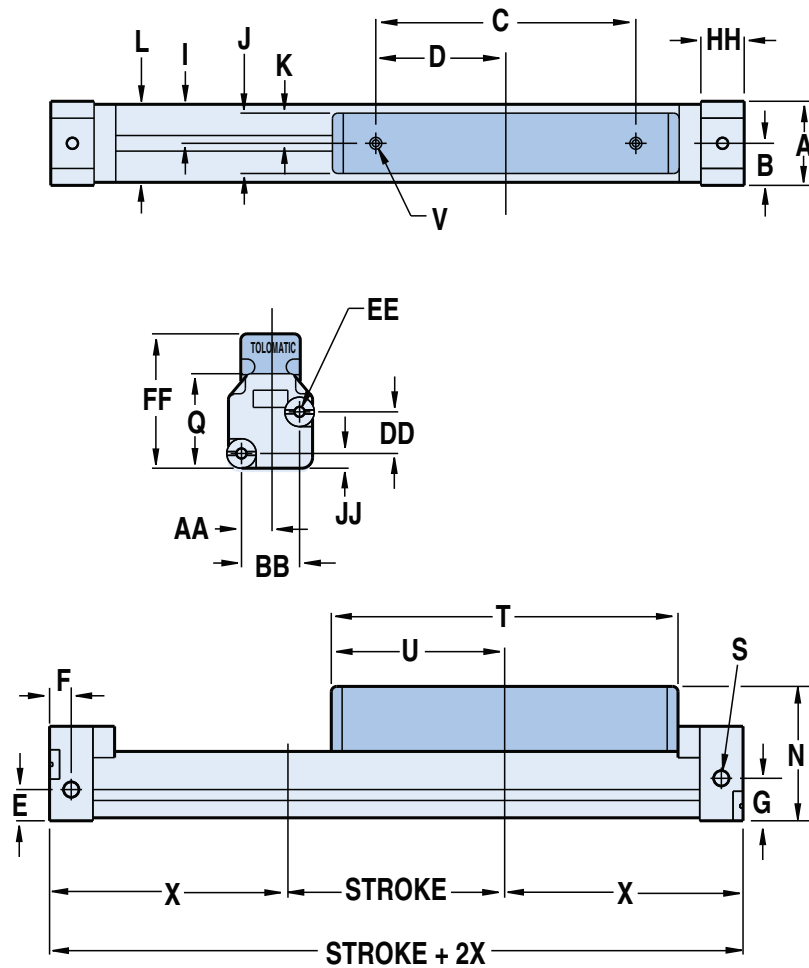

	U.S. Standard	Metric
A	0.97	24.6
B	0.48	12.3
C	3.00	76.2
D	1.50	38.1
E	0.36	9.1
F	0.25	6.35
G	0.49	12.4
I	0.45	11.45
J	0.70	17.8
K	0.35	8.9
L	0.90	22.9
N	1.55	39.4
Q	1.09	27.7
S	#10-32 UNF	M5
T	4.00	101.6
U	2.00	50.8
V	2x #6-32 UNC x .38 DEEP	M3 x 9.7 DEEP
X*	2.60 @ 80-100 PSI	66.0 @ 80-100 PSI
	2.66 @ 40-80 PSI	67.6 @ 40-80 PSI
	2.71 @ 0-40 PSI	68.8 @ 0-40 PSI
AA	0.33	8.4
BB	0.66	16.8
DD	0.48	12.2
EE	4x #6-32UNC x .25 DEEP	M3 x 6.4 DEEP
FF	1.55	39.4
HH	0.50	12.7
JJ	0.17	4.3
	INCHES	MILLIMETERS

SPECIFICATIONS

BC205 BENDING MOMENTS AND LOAD

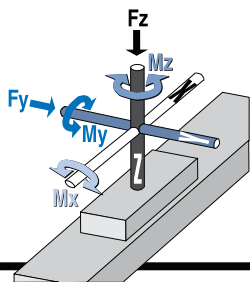

	BORE SIZE	MAX. BENDING MOMENT			MAX. LOAD
		My	Mx	Mz	Fz
U.S.	0.50 in	9.0 in-lbs	2.0 in-lbs	3.0 in-lbs	5.0 lbs
Metric	12 mm	1.01 N-m	0.22 N-m	0.33 N-m	2.27 kg

	BORE SIZE	WEIGHT		MAX. STROKE LENGTH*	MAX. PRESSURE	TEMPERATURE RANGE
		BASE	PER UNIT OF STROKE			
U.S.	0.50 in	0.38 lb	0.036 lb/in	171 in	100 PSI	20° to 140° F
Metric	12 mm	0.169 kg	0.0164 kg/mm	4343 mm	6.895 bar	-7° to 60° C

*For longer strokes, alternate materials, mounting and/or fasteners – consult Tolomatic

BC210 Solid Bearing Rodless Cylinder

PERFORMANCE

BC210



BC210 OPTIONS	Page
Auxiliary Carrier	BC2_14
Floating Mount	BC2_18
Foot Mount	BC2_17
Shock Absorbers	BC2_22
Switches	BC2_20
Tube Supports	BC2_16
MORE INFORMATION	Page
Application Guidelines	BC2_26
Ordering	BC2_28
Selection	BC2_25

THEORETICAL FORCE vs PRESSURE

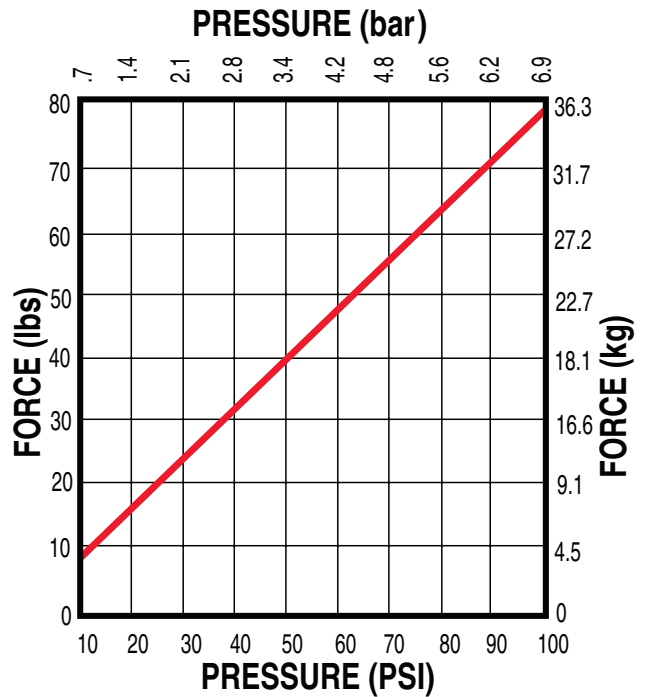

CUSHION DATA

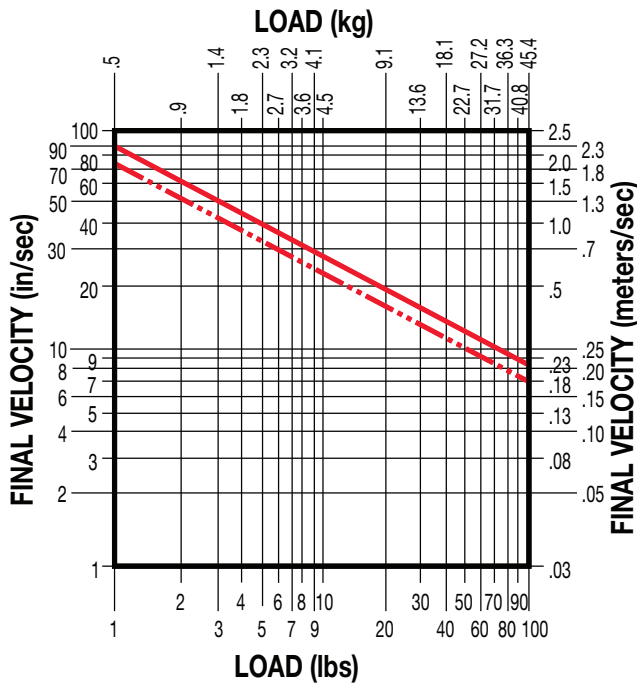

NOTE:
— Max. for any application
- - - Max. for continuously cycled application

TUBE SUPPORT REQUIREMENTS

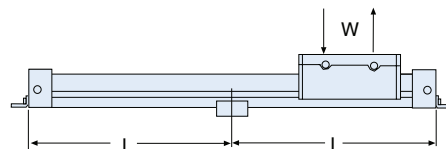
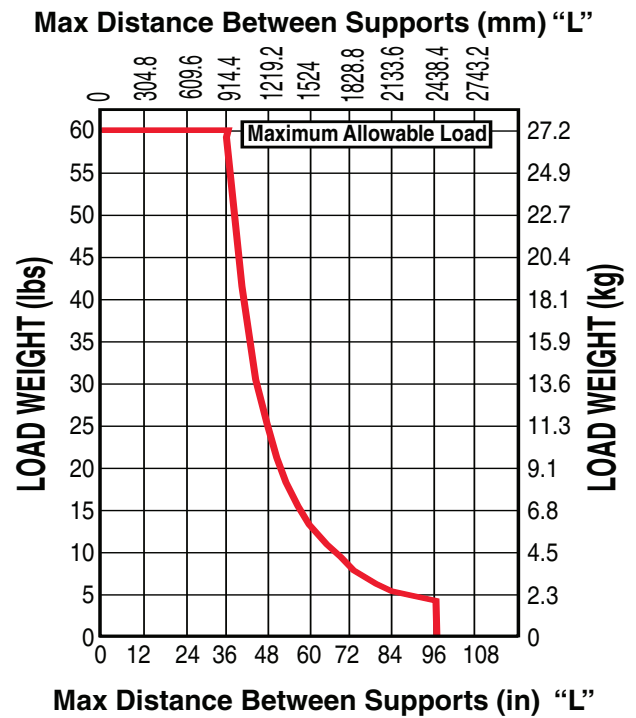

BC210 Solid Bearing Rodless Cylinder

3D CAD available at
www.tolomatic.com



DIMENSIONS

Always use configured CAD solid model to determine critical dimensions

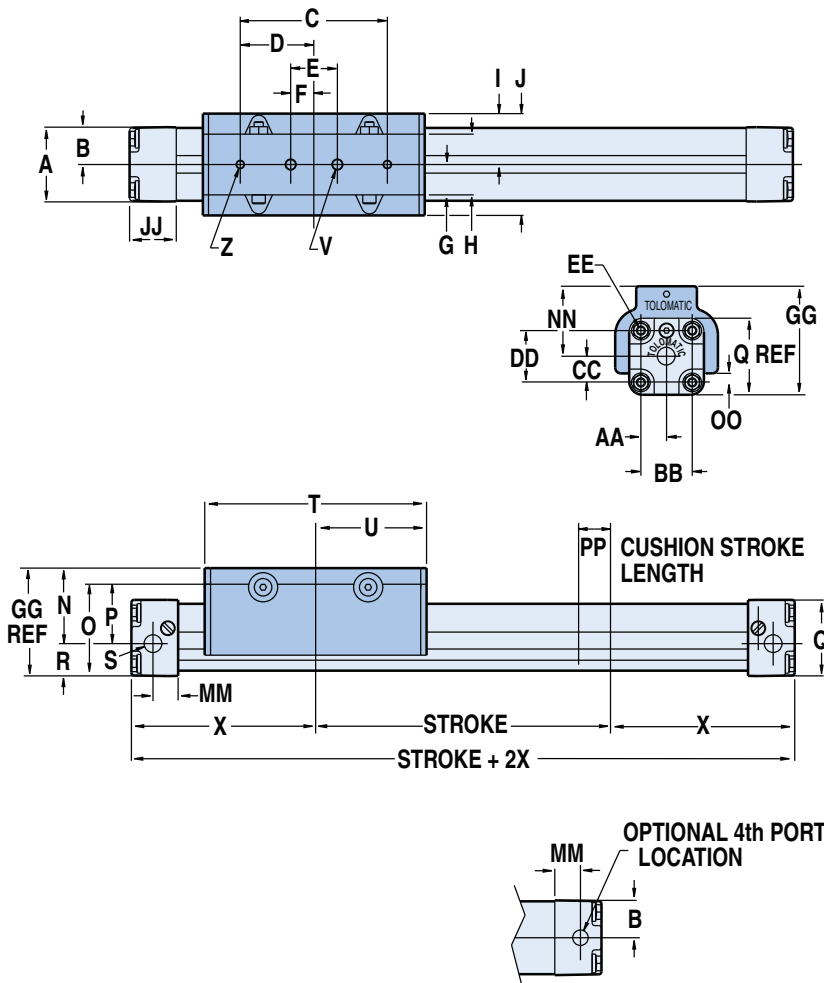

	U.S. Standard	Metric
A	1.58	40.1
B	0.79	20.1
C	3.15	80.0
D	1.57	40.0
E	1.00	25.4
F	0.50	12.7
G	0.65	16.5
H	1.30	33.0
I	1.09	27.7
J	2.18	55.4
N	1.62	41.2
O	1.88	47.7
P	1.20	30.5
Q	1.64	41.5
R	0.68	17.3
S	1/8 NPT (3)	TP 1/8 BSPT(3) GP 1/8 BSPP(3)
T	4.75	120.7
U	2.37	60.2
V	1/4-20 UNC X .25 DEEP	M6 X 6 DEEP
X	3.94	100.1
Z	10-32 UNC X .25 DEEP	M6 X 6 DEEP
AA	0.55	14.0
BB	1.10	27.9
CC	0.55	14.0
DD	1.10	27.9
EE	10-24 X .43 DEEP	M5 X 11.0 DEEP
GG	2.30	58.4
JJ	1.00	25.4
MM	0.55	14.0
NN	1.50	38.1
OO	0.18	4.7
PP	0.68	17.3
	INCHES	MILLIMETERS

SPECIFICATIONS

BC210 BENDING MOMENTS AND LOAD

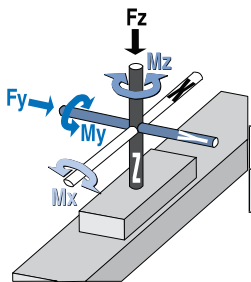

	BORE SIZE	MAX. BENDING MOMENT			MAX. LOAD
		My	Mx	Mz	Fz
U.S.	1.00 in	100 in-lbs	55 in-lbs	30 in-lbs	60 lbs
Metric	25 mm	11.29 N-m	6.21 N-m	3.39 N-m	27.21 kg

	BORE SIZE	WEIGHT		MAX. STROKE LENGTH*	MAX. PRESSURE	TEMPERATURE RANGE
		BASE	PER UNIT OF STROKE			
U.S.	1.00 in	2.26 lbs	0.14 lbs/in	350 in	100 PSI	20° to 140° F
Metric	25 mm	1.025 kg	0.0024 kg/mm	8890 mm	6.895 bar	-7° to 60° C

***For longer strokes, alternate materials, mounting and/or fasteners – consult Tolomatic**

BC212 & BC215 Solid Bearing Rodless Cylinder

PERFORMANCE

BC212
BC215



BC212 & BC215 OPTIONS		Page
Auxiliary Carrier	BC2_14	
Floating Mount	BC2_18	
Foot Mount	BC2_17	
Shock Absorbers	BC2_22	
Switches	BC2_20	
Tube Supports	BC2_16	
MORE INFORMATION		Page
Application Guidelines	BC2_26	
Ordering	BC2_28	
Selection	BC2_25	

THEORETICAL FORCE vs PRESSURE

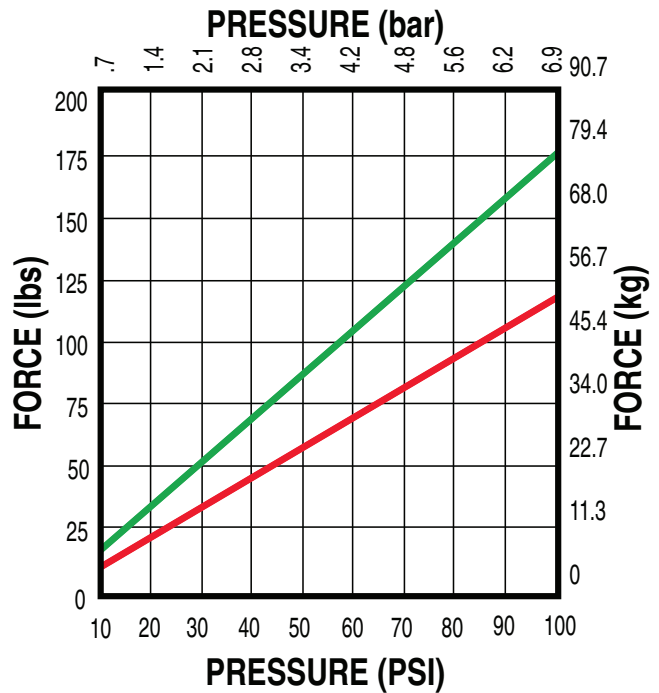

TUBE SUPPORT REQUIREMENTS

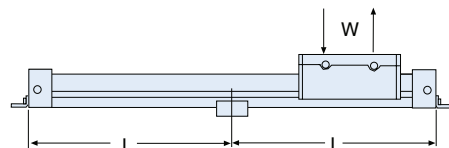
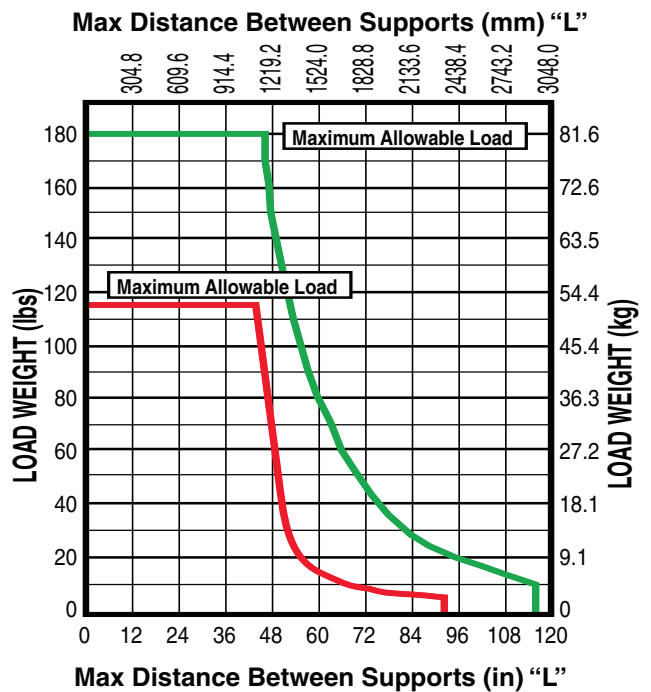

CUSHION DATA

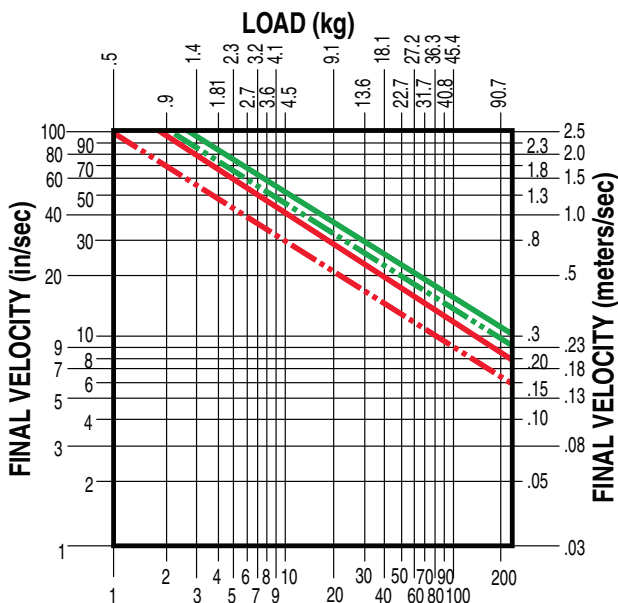

NOTE:
— Max. for any application
- - - Max. for continuously cycled application

BC212 & BC215 Solid Bearing Rodless Cylinder

3D CAD available at
www.tolomatic.com



DIMENSIONS

Always use configured CAD solid model to determine critical dimensions

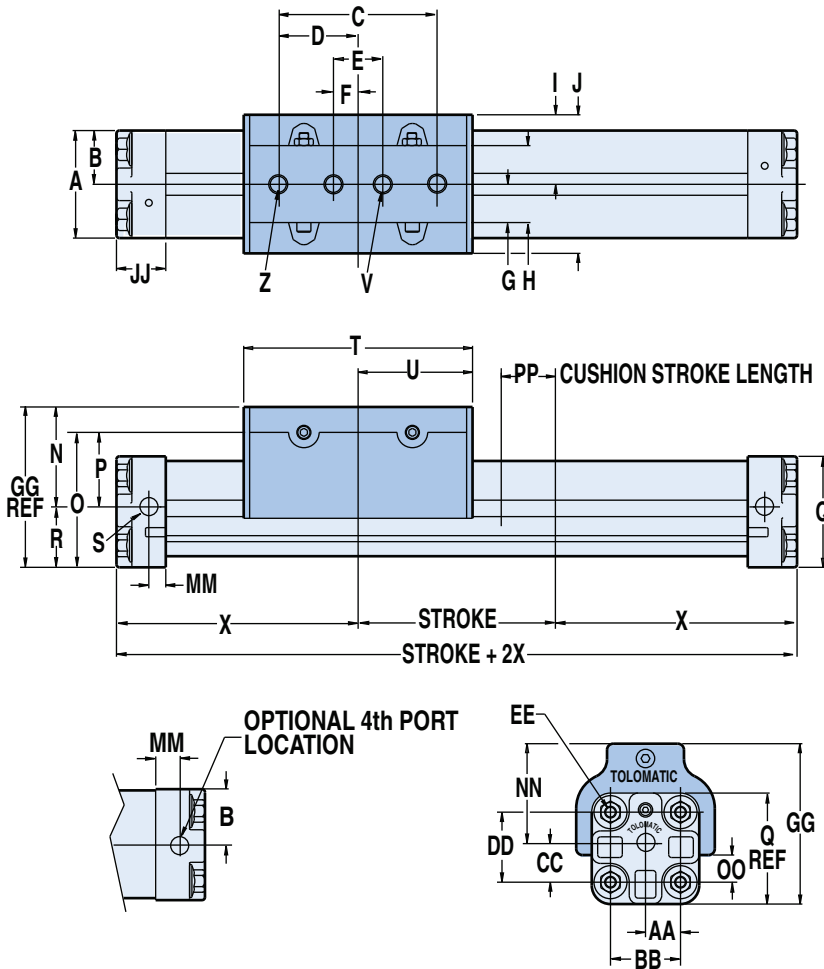

	U.S.12	U.S.15	Metric12	Metric15
A	2.18	2.85	55.4	72.4
B	1.09	1.42	27.7	36.1
C	3.20	4.25	81.3	108.0
D	1.60	2.12	40.6	53.8
E	1.00	1.00	25.4	25.4
F	0.50	0.50	12.7	12.7
G	0.78	0.90	19.8	22.9
H	1.56	1.80	39.6	45.7
I	1.41	1.75	35.8	44.5
J	2.82	3.50	71.6	89.0
N	1.83	2.13	46.5	54.1
O	2.48	2.95	63.0	74.9
P	1.25	1.51	31.0	38.4
Q	2.25	2.59	57.2	65.8
R	1.23	1.41	31.2	36.6
S	1/4 NPT (3)	1/4 NPT (3)	M 1/4 BSPT(3) MM 1/4 BSPP(3)	M 1/4 BSPT(3) MM 1/4 BSPP(3)
T	4.64	5.91	117.9	150.1
U	2.32	2.96	58.9	75.1
V	5/16-18 UNC x .31 DP	1/4-20 UNC x .38 DP	M8 x 7 DP	M8 x 10 DP
X	4.87	5.91	123.7	150.1
Z	1/4-20 UNC x .31 DP	5/16-18 UNC x .38 DP	M8 x 7 DP	M8 x 10 DP
AA	0.71	0.91	18.0	23.1
BB	1.42	1.81	36.1	46.0
CC	0.78	1.03	19.8	26.2
DD	1.42	1.81	36.1	46.0
EE	1/4-20 x .47 DP	1/4-20 x .47 DP	M6 x 12 DP	M6 x 12 DP
GG	3.06	3.54	77.7	90.7
JJ	1.00	1.25	25.4	31.8
MM	0.34	0.50	8.6	12.7
NN	1.83	2.13	46.5	54.1
OO	0.35	0.28	9.0	7.0
PP	1.10	1.29	27.9	32.7
	INCHES		MILLIMETERS	

SPECIFICATIONS

BC212/15 BENDING MOMENTS AND LOAD

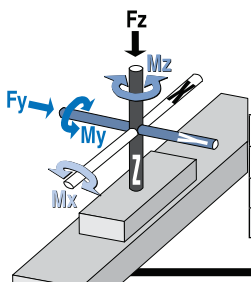

	BORE SIZE	MAX. BENDING MOMENT			MAX. LOAD
		My	Mx	Mz	Fz
U.S.12	1.25 in	290 in-lbs	75 in-lbs	130 in-lbs	120 lbs
U.S.15	1.50 in	500 in-lbs	275 in-lbs	200 in-lbs	180 lbs
Metric12	32 mm	32.77 N-m	8.47 N-m	14.69 N-m	54.42 kg
Metric15	40 mm	56.49 N-m	31.07 N-m	22.60 N-m	81.63 kg

	BORE SIZE	WEIGHT		MAX. STROKE LENGTH*	MAX. PRESSURE	TEMPERATURE RANGE
		BASE	PER UNIT OF STROKE			
U.S.12	1.25 in	4.56 lbs	0.21 lbs/in	288 in	100 PSI	20° to 140° F
U.S.15	1.50 in	8.18 lbs	0.34 lbs/in	298 in	100 PSI	20° to 140° F
Metric12	32 mm	2.068 kg	0.0036 kg/mm	7315 mm	6.895 bar	-7° to 60° C
Metric15	40 mm	3.7 kg	0.0058 kg/mm	7569 mm	6.895 bar	-7° to 60° C

*For longer strokes, alternate materials, mounting and/or fasteners – consult Tolomatic

BC220 & BC225 Solid Bearing Rodless Cylinder

PERFORMANCE

BC220
BC225



BC220 & BC225 OPTIONS		Page
Auxiliary Carrier	BC2_14	
Floating Mount	BC2_18	
Foot Mount	BC2_17	
Shock Absorbers	BC2_22	
Switches	BC2_20	
Tube Supports	BC2_16	
MORE INFORMATION		Page
Application Guidelines	BC2_26	
Ordering	BC2_28	
Selection	BC2_25	

THEORETICAL FORCE vs PRESSURE

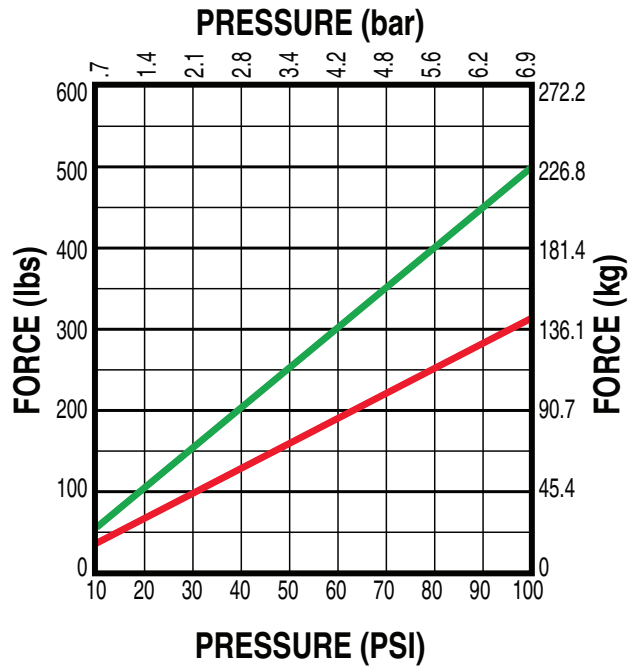

TUBE SUPPORT REQUIREMENTS

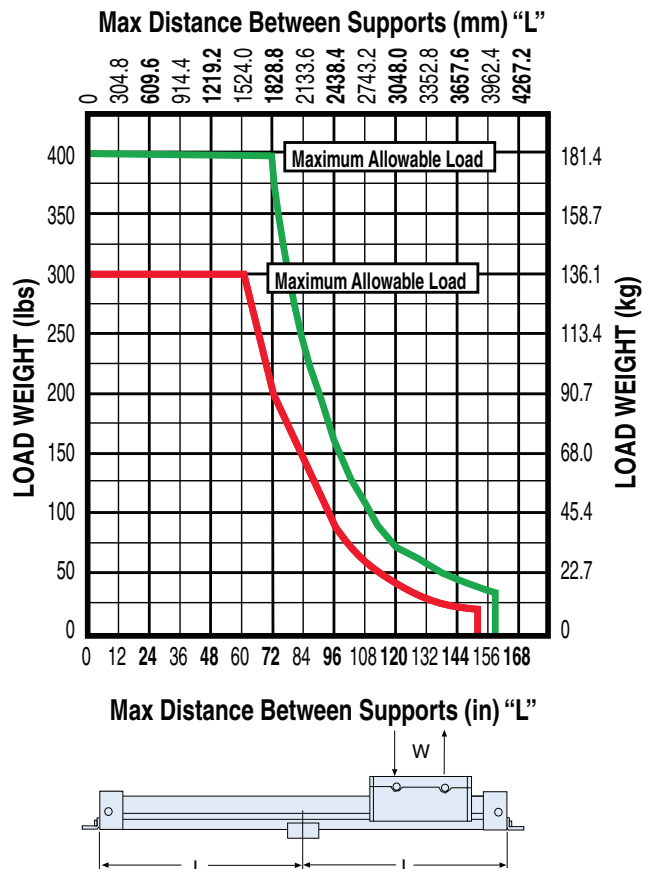

CUSHION DATA

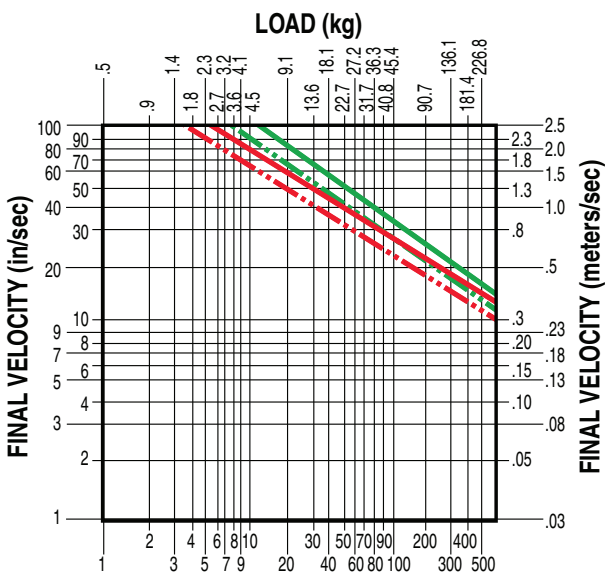

NOTE:
 — Max. for any application
 - - - - - Max. for continuously cycled application

BC220 & BC225 Solid Bearing Rodless Cylinder

3D CAD available at
www.tolomatic.com



DIMENSIONS

Always use configured CAD solid model to determine critical dimensions

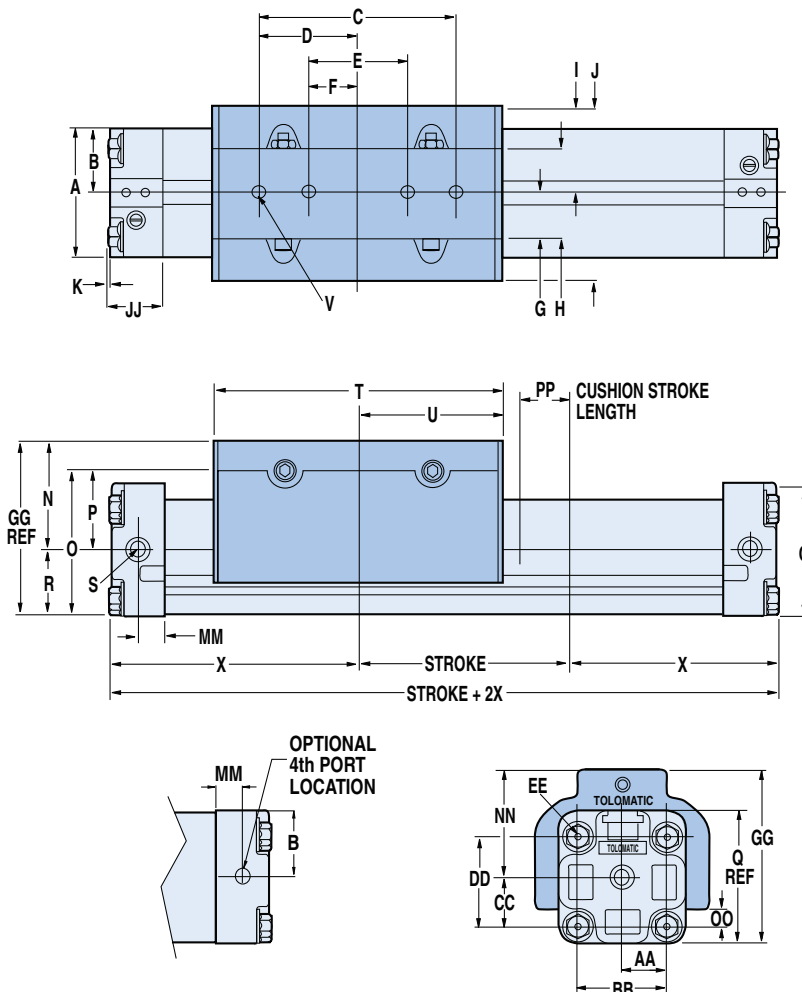

	U.S.20	U.S.25	Metric20	Metric25
A	3.25	4.25	82.6	108.0
B	1.62	2.13	41.1	54.1
C	5.00	6.00	127.0	152.4
D	2.50	3.00	63.5	76.2
E	2.50	3.00	63.5	76.2
F	1.25	1.50	31.8	38.1
G	1.16	1.27	29.5	32.4
H	2.30	2.55	58.4	64.8
I	2.22	2.81	56.4	71.4
J	4.44	5.62	112.8	142.8
K	0.06	0.03	1.5	0.8
N	2.75	3.20	69.9	81.3
O	3.69	4.67	93.7	118.6
P	2.00	2.37	50.8	60.2
Q	3.38	4.37	85.9	111.0
R	1.69	2.30	42.9	58.4
S	3/8 NPT (3)	3/8 NPT (3)	M 3/8 BSPT(3)	M 3/8 BSPT(3)
			GP 3/8 BSPP(3)	GP 3/8 BSPP(3)
T	7.37	8.86	187.2	225.0
U	3.68	4.43	93.5	112.5
V	3/8-16 UNC x .44 DP	3/8-16 UNC x .50 DP	M10 x 11 DP	M10 x 12 DP
X	6.30	8.45	160.0	214.6
AA	1.12	1.44	28.5	36.6
BB	2.25	2.88	57.2	73.2
CC	1.25	1.75	31.8	44.5
DD	2.25	2.88	57.2	73.2
EE	5/16-18 x .88 DP	5/16-18 x .88 DP	M8 x 22 DP	M8 x 22 DP
GG	4.44	5.50	112.8	139.7
JJ	1.44	2.06	36.6	52.3
MM	0.69	1.00	17.5	25.4
NN	2.75	3.20	69.9	81.3
OO	0.43	0.76	10.9	19.3
PP	1.35	1.97	34.3	50.0
	INCHES		MILLIMETERS	

SPECIFICATIONS

BC220/25 BENDING MOMENTS AND LOAD

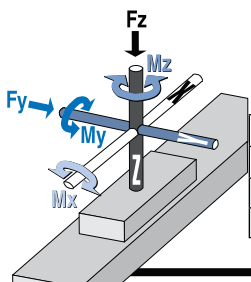

	BORE SIZE	MAX. BENDING MOMENT			MAX. LOAD
		My	Mx	Mz	Fz
U.S.20	2.00 in	1,100 in-lbs	300 in-lbs	325 in-lbs	300 lbs
U.S.25	2.50 in	1,800 in-lbs	450 in-lbs	400 in-lbs	400 lbs
Metric20	50 mm	124.28 N-m	33.90 N-m	36.72 N-m	136.05 kg
Metric25	63 mm	203.37 N-m	50.84 N-m	45.19 N-m	181.4 kg

	BORE SIZE	WEIGHT		MAX. STROKE LENGTH*	MAX. PRESSURE	TEMPERATURE RANGE
		BASE	PER UNIT OF STROKE			
U.S.20	2.00 in	14.12 lbs	0.54 lbs/in	274 in	100 PSI	20° to 140° F
U.S.25	2.50 in	31.90 lbs	1.01 lbs/in	163 in	100 PSI	20° to 140° F
Metric20	50 mm	6.4 kg	0.0093 kg/mm	6959 mm	6.895 bar	-7° to 60° C
Metric25	63 mm	14.467 kg	0.0173 kg/mm	4140 mm	6.895 bar	-7° to 60° C

*For longer strokes, alternate materials, mounting and/or fasteners – consult Tolomatic

BC2 Auxiliary Carrier - 10, 12, 15, 20, 25 Sizes

PERFORMANCE

The auxiliary carrier option substantially increases load carrying and bending moments capacity over the standard single carrier models. As a general rule, the auxiliary carrier option is highly recommended in vertical applications (My) if the distance from the carrier mounting surface to the load center of gravity (CG) exceeds the overall length of the carrier. Auxiliary carriers can be ordered with (DW) or without (DO) an internal piston. (Auxiliary carriers without a piston have no cushion on the cylinder end closest to the auxiliary carrier.)



NOTE: breakaway pressure will increase when using auxiliary carrier.

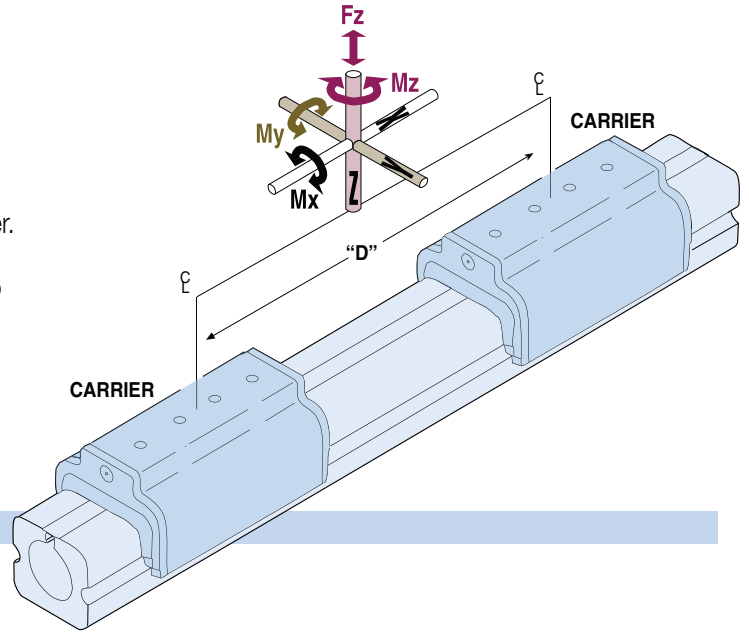

BENDING MOMENTS

MOMENT LOAD vs. DISTANCE

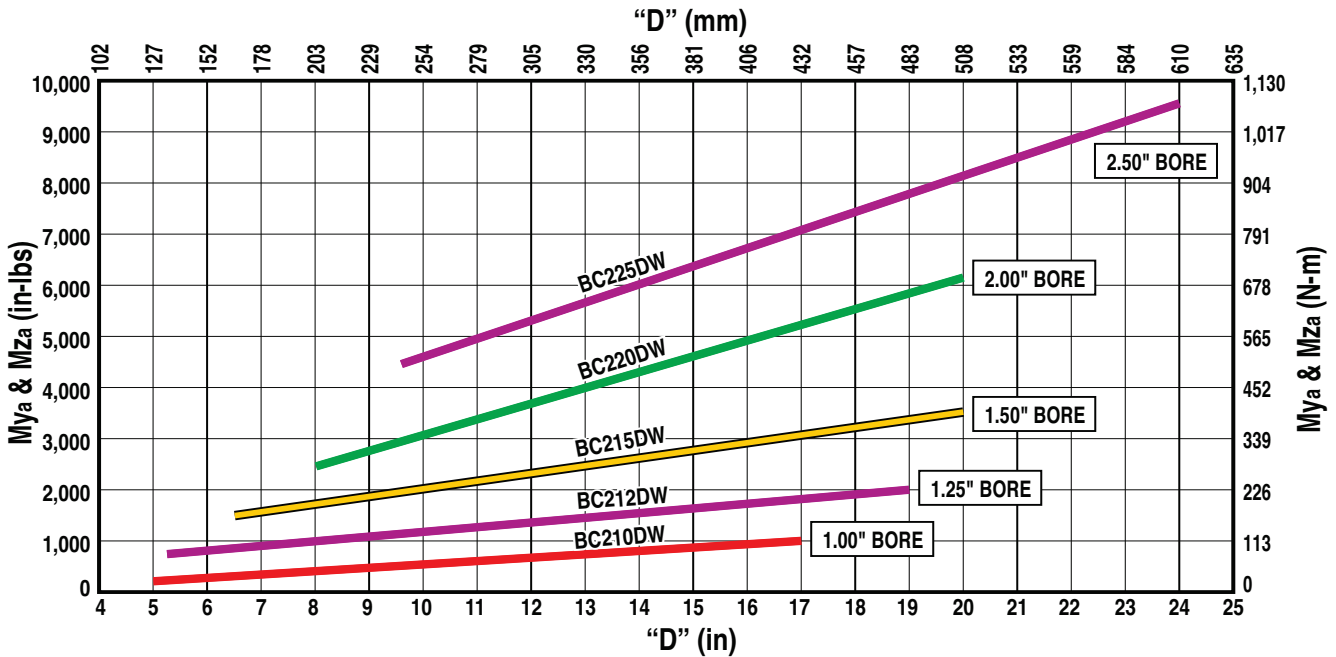

Rates were calculated with the following assumptions:

- 1.) Coupling between carriers is rigid.
- 2.) Load is equally distributed between carriers.
- 3.) Coupling device applies no misalignment loads to carriers.

	BORE SIZE		"D" MINIMUM *				MAX. BENDING MOMENT						MAX. LOAD	
			(w/o Piston)		(w/ Piston)		My**		Mx		Mz**		Fz	
	in	mm	in	mm	in	mm	in-lbs	N-m	in-lbs	N-m	in-lbs	N-m	lbs	kg
10	1.00	25	5.07	129.0	5.07	129.0	287	32.4	110	12.4	287	32.4	120	54.4
12	1.25	32	5.17	131.0	6.85	174.0	822	92.9	150	16.9	822	92.9	240	108.9
15	1.50	40	6.46	164.0	8.07	205.0	1,453	164.1	550	62.1	1,453	164.1	360	163.3
20	2.00	50	8.10	206.0	8.10	206.0	2,430	274.6	600	67.8	2,430	274.6	600	272.2
25	2.50	63	9.62	244.0	11.04	2810.4	4,416	498.9	900	101.7	4,416	498.9	800	362.9

* "D" is distance between carriers

** Loads calculated are at minimum "D", for substantially higher My and Mz loads increase "D" and refer to graph above

BC2 Auxiliary Carrier - 10, 12, 15, 20, 25 Sizes

3D CAD available at
www.tolomatic.com



DIMENSIONS

Always use configured CAD solid model to determine critical dimensions

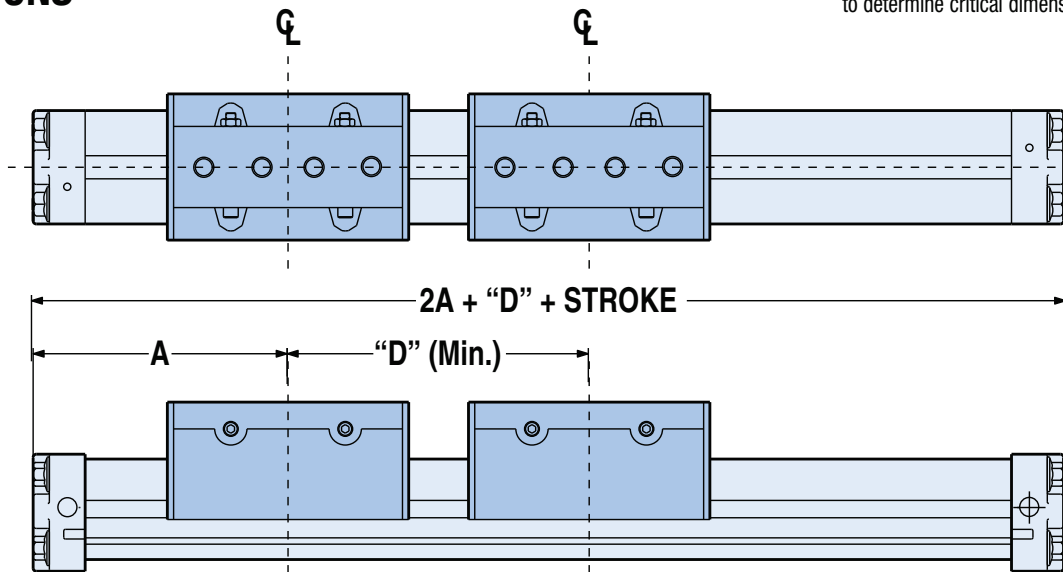

	BORE SIZE		A		"D" MINIMUM *			
	in	mm	in	mm	(w/o Piston)		(w/ Piston)	
					in	mm	in	mm
10	1.00	25	3.94	100.1	5.07	129.0	5.07	129.0
12	1.25	32	4.90	124.5	5.17	131.0	6.85	174.0
15	1.50	40	5.91	150.1	6.46	164.0	8.07	205.0
20	2.00	50	6.30	160.0	8.10	206.0	8.10	206.0
25	2.50	63	8.46	214.9	9.62	244.0	11.04	280.4

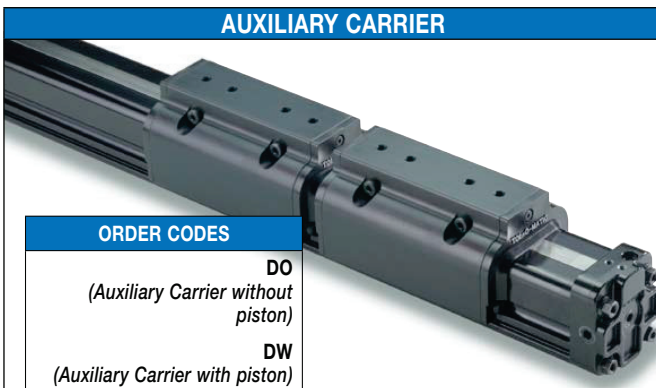

ASSEMBLY INFORMATION

IMPORTANT INFORMATION REGARDING AUXILIARY CARRIER PLACEMENT

When a BC2 cylinder is ordered with auxiliary carrier, it is always placed to the right (while facing the switch mounted or open port side) of the main carrier. This is for auxiliary carriers with (DW)/or without (DO) piston and for units with/ or without shock absorbers. When the auxiliary carrier is ordered without (DO) piston the carrier without piston will be marked.

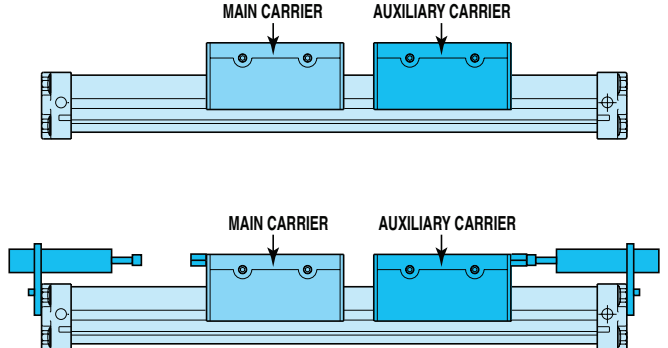

ORDERING INFORMATION

When ordering, determine the minimum distance required between carriers (dimension "D" in Auxiliary Carrier Bending Moments chart).

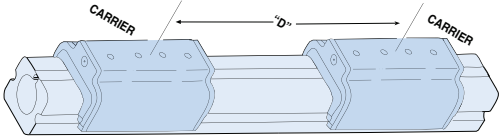

Determine your working stroke and your "D" dimension, then enter these into your configuration string. (Example: BC215SK50.00DW15.00RT2) The configurator will calculate the overall length of the actuator.

ART
MXP
BC2
BC3
BC4
LS
IMG
CC
PB
ENGR

BC2 Tube Supports - ALL Sizes

3D CAD available at
www.tolomatic.com



Always use configured CAD solid model to determine critical dimensions



Tube supports are mounted to the BC2 band cylinder during assembly procedure. Made of black-anodized aluminum, tube supports are designed to fit into dovetail grooves which run the length of the cylinder tube. Refer to the tube support graph to determine the number of tube supports required.



NOTE: Switches cannot be mounted on the same face of the actuator as tube supports.

PERFORMANCE

TUBE SUPPORT REQUIREMENTS

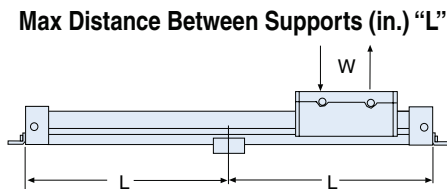
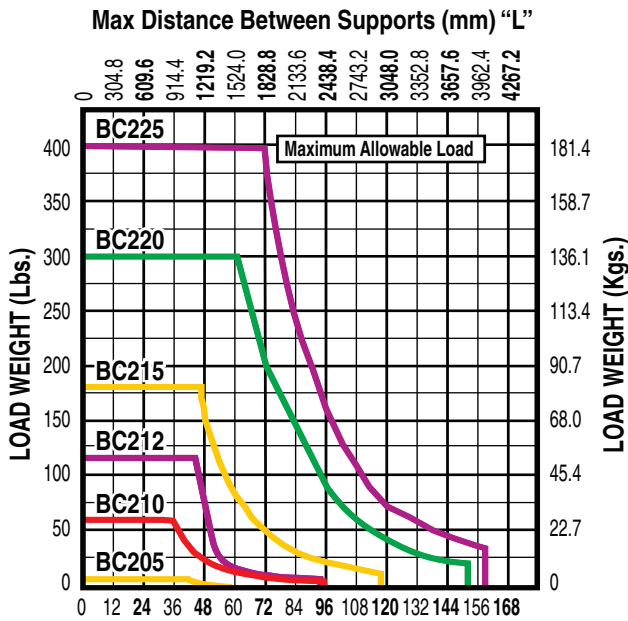

DIMENSIONS

05

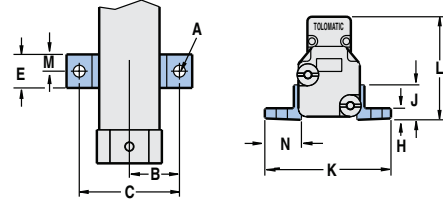

10, 12, 15, 20, 25

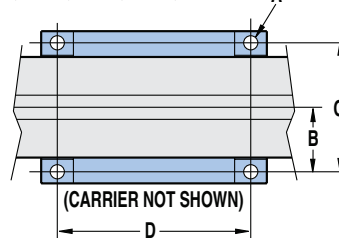

10, 12, 15, 20

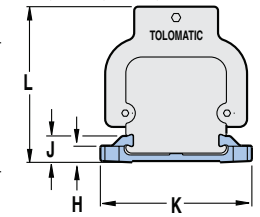

10, 12, 15, 20, 25

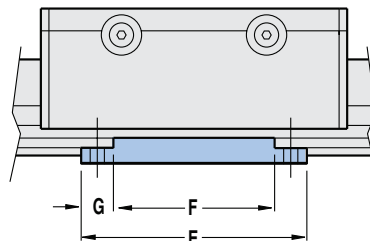

25

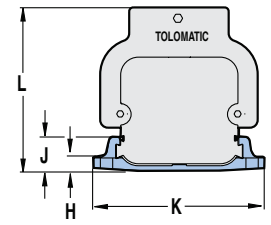

U.S. Standard	BORE SIZE	A Ø	B	C	D	E	F	G	H	J	K	L	M	N
05	0.50	0.18	0.75	1.50	-	0.50	-	-	0.18	0.54	1.88	1.60	0.65	0.50
10	1.00	0.22	1.00	2.00	3.00	3.50	2.50	0.50	0.25	0.41	2.36	2.43	-	-
12	1.25	0.27	1.31	2.63	4.50	5.00	4.00	0.50	0.40	0.81	3.12	3.23	-	-
15	1.50	0.27	1.50	3.00	4.50	5.00	4.00	0.50	0.31	0.70	3.50	3.62	-	-
20	2.00	0.41	1.875	3.750	5.75	6.38	5.00	0.69	0.375	0.87	4.44	4.53	-	-
25	2.50	0.42	2.563	5.125	7.75	8.50	7.00	0.75	0.437	1.17	6.00	5.56	-	-

Dimensions in inches

Metric	BORE SIZE	A Ø	B	C	D	E	F	G	H	J	K	L	M	N
05	12	4.6	19.1	38.1	-	12.7	-	-	4.6	13.7	47.7	40.6	16.5	12.7
10	25	5.6	25.4	50.8	76.2	88.9	63.5	12.7	6.3	10.4	59.9	61.7	-	-
12	32	6.7	33.3	66.8	114.3	127.0	101.6	12.7	10.2	20.6	79.2	82.0	-	-
15	40	6.7	38.1	76.2	114.3	127.0	101.6	12.7	7.9	17.8	88.9	91.9	-	-
20	50	10.5	47.6	95.3	146.1	162.1	127.0	17.5	9.5	22.1	112.8	115.1	-	-
25	63	10.7	65.1	130.2	196.9	215.9	177.8	19.1	11.1	29.7	152.4	141.2	-	-

Dimensions in millimeters

BC2 Foot Mounts - ALL Sizes

3D CAD available at
www.tolomatic.com



Always use configured CAD solid model to determine critical dimensions

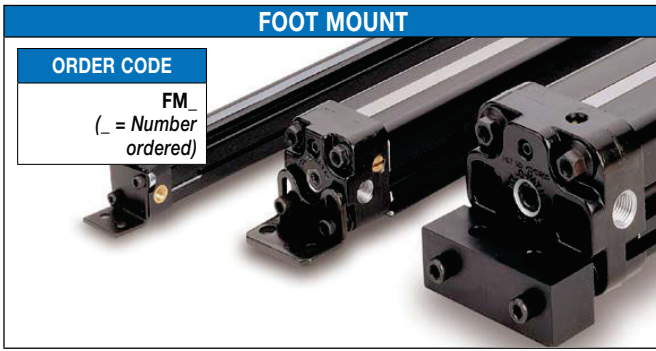

ORDER CODE
FM
(_ = Number ordered)

For mounting other than flush. Foot mounts may be specified on one or both ends of the cylinder.

DIMENSIONS

05

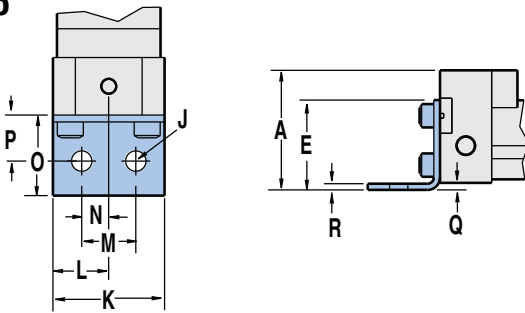

15

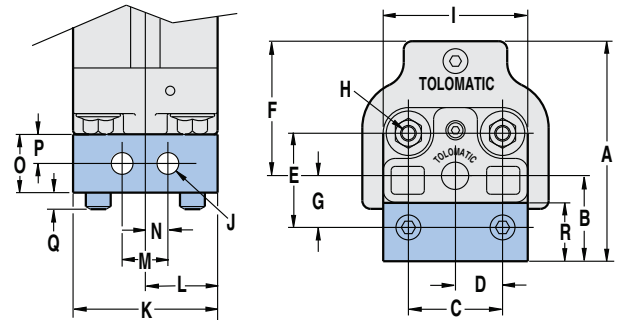

10, 12

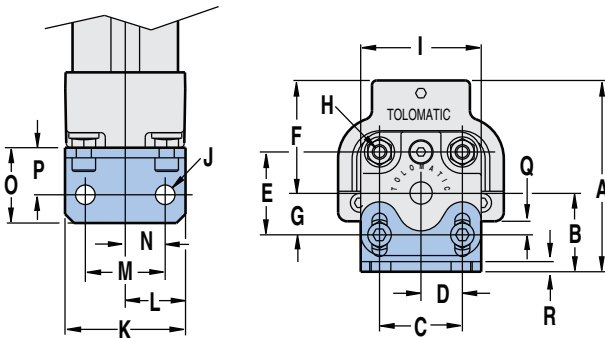

20, 25

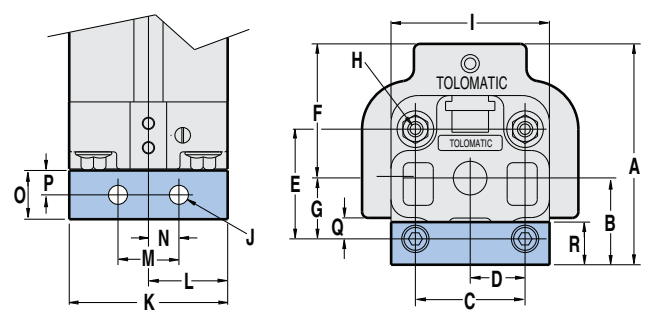

U.S. Std.	BORE SIZE	A	B	C	D	E	F	G	H	I	J Ø	K	L	M	N	O	P	Q	R
05	0.50	1.62	-	-	-	0.87	-	-	-	-	0.180	0.97	0.49	0.47	0.24	0.70	0.40	0.06	0.06
10	1.00	2.36/2.73	0.86/1.23	1.10	0.55	1.10	1.50	0.55	#10-24 x .43 DP	1.58	0.260	1.60	0.80	1.06	0.53	1.00	0.63	0.18	0.14
12	1.25	3.21/3.71	1.38/1.88	1.42	0.71	1.42	1.83	0.78	1/4-20 x .47 DP	2.18	0.328	2.09	1.05	1.42	0.71	0.84	0.49	0.35	0.13
15	1.50	3.69	1.56	1.82	0.91	1.81	2.13	1.03	1/4-20 x .47 DP	2.85	0.328	2.83	1.42	1.18	0.59	1.00	0.50	0.25	1.00
20	2.00	4.53	1.78	2.25	1.13	2.25	2.75	1.25	5/16-18 x 1.0 DP	3.25	0.390	3.25	1.63	1.25	0.63	1.00	0.50	0.43	0.88
25	2.50	5.65	2.45	2.88	1.44	2.88	3.20	1.75	5/16-18 x 1.0 DP	4.25	0.437	4.25	2.13	1.89	0.95	1.18	0.59	0.76	1.00

Dimensions in inches

Metric	BORE SIZE	A	B	C	D	E	F	G	H	I	J Ø	K	L	M	N	O	P	Q	R
05	12	41.1	-	-	-	22.1	-	-	-	-	4.6	24.6	12.3	11.9	6.0	20.4	10.2	1.5	1.5
10	25	59.7/69.3	21.8/31.2	27.9	14.0	27.9	38.1	14.0	M5 x 11 DP	40.1	6.6	40.6	20.3	26.9	13.5	25.4	15.9	4.7	3.4
12	32	81.5/94.2	35.1/47.8	36.1	18.0	36.1	46.5	19.8	M6 x 12 DP	55.4	8.3	53.1	26.7	36.1	18.0	21.3	12.4	9.0	3.2
15	40	93.7	39.6	46.2	23.1	46.0	54.1	26.2	M6 x 12 DP	72.4	8.3	71.9	36.1	30.0	15.0	25.4	12.7	6.0	25.4
20	50	115.1	45.7	57.2	28.7	57.2	69.9	31.8	M8 x 25 DP	82.6	9.9	82.6	41.2	31.8	16.0	25.4	12.7	10.9	22.2
25	63	143.5	62.2	73.2	35.6	73.2	81.3	44.5	M8 x 25 DP	108.0	11.1	108.0	54.1	48.0	24.1	30.0	15.0	19.3	25.4

Dimensions in millimeters

BC2 Floating Mount Bracket - ALL Sizes

3D CAD available at
www.tolomatic.com



Always use configured CAD solid model
to determine critical dimensions

FLOATING MOUNT BRACKET

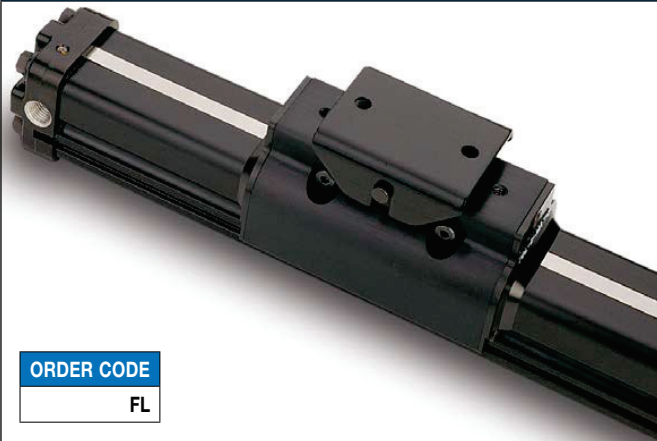

ORDER CODE

FL

For applications where a BC2 band cylinder is moving a load that is externally guided and supported. An externally guided load, not parallel to the BC2 band cylinder may result in cylinder binding. The floating mount bracket compensates for nonparallelism between the cylinder and the external guide.

⊗ (Floating mount brackets are not to be used in conjunction with shock absorbers)

DIMENSIONS

05

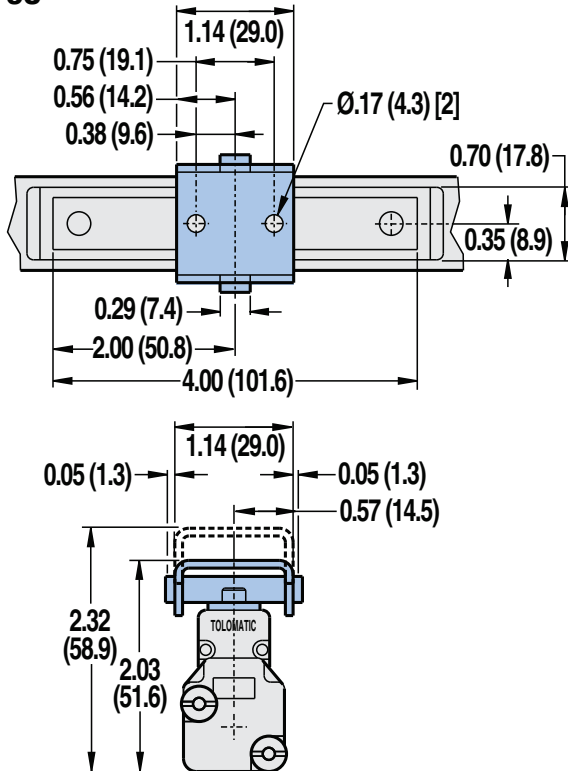

10

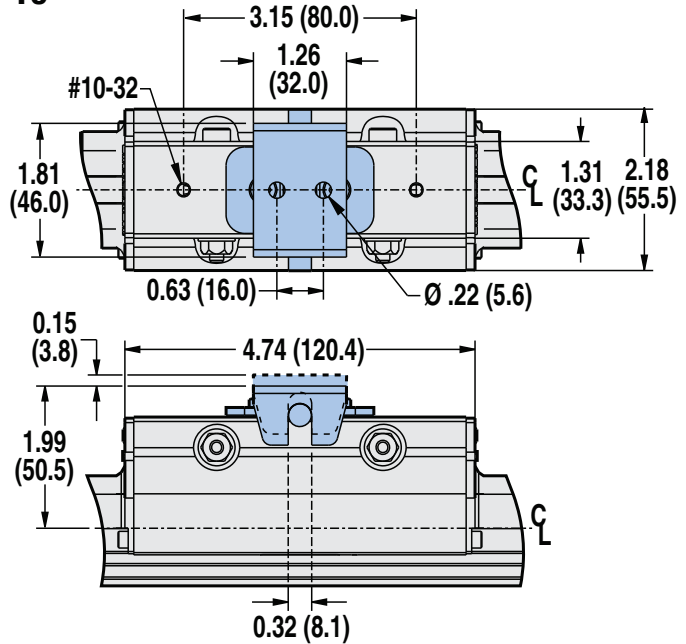

Dimensions in inches (parenthesis indicate dimensions in millimeters)

BC2 Floating Mount Bracket - ALL Sizes

3D CAD available at
www.tolomatic.com



Always use configured CAD solid model
to determine critical dimensions

DIMENSIONS

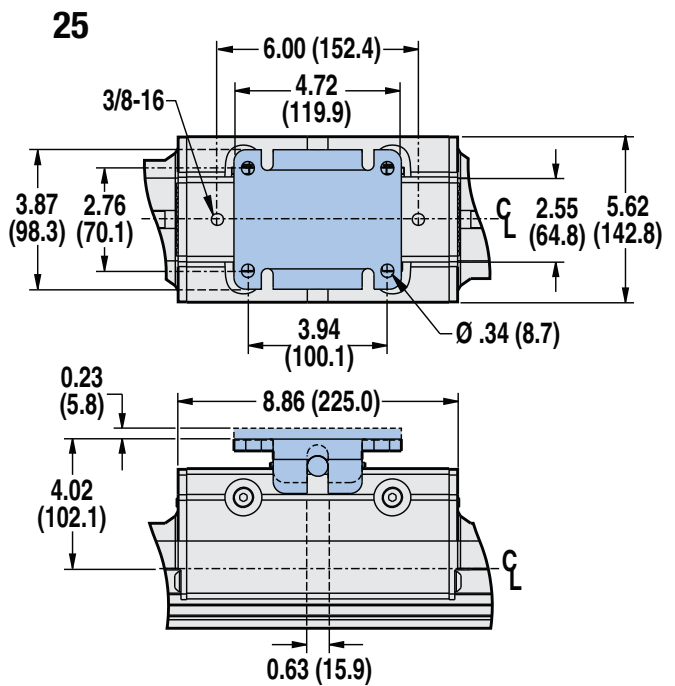
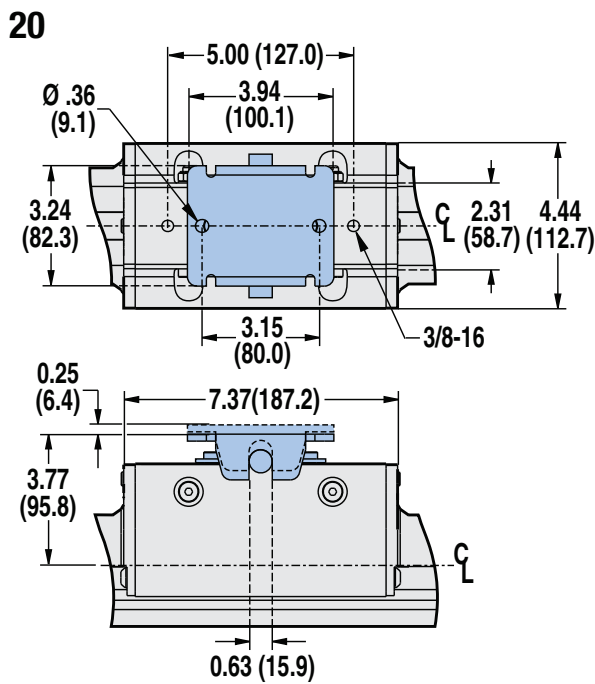
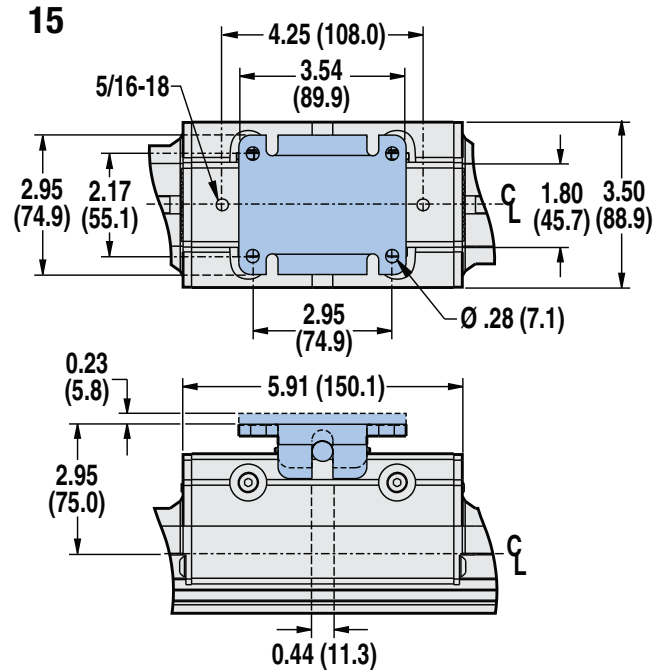
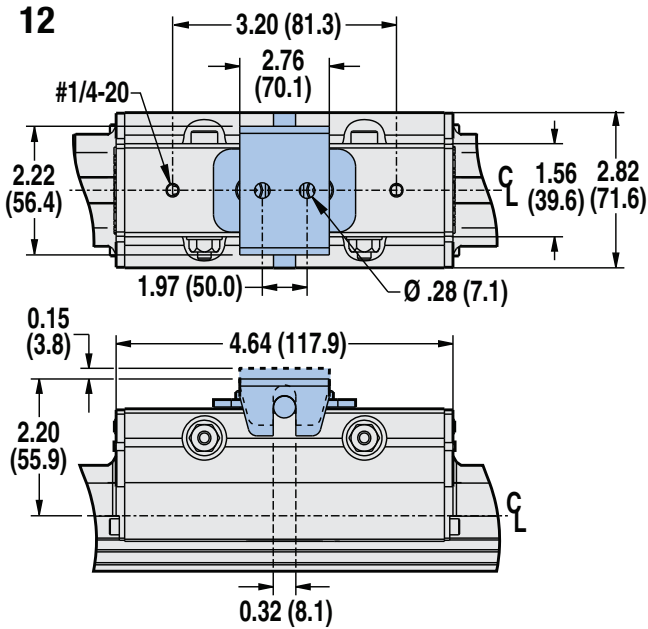

Dimensions in inches (parenthesis indicate dimensions in millimeters)

ART
MXP
BC2
BC3
BC4
LS
MG
CC
PB
ENGR

BC2 Switches - ALL Sizes

SWITCHES

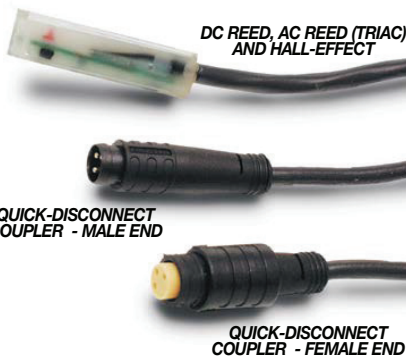

There are 10 sensing choices: DC reed, form A (open) or form C (open or closed); AC reed (Triac, open); Hall-effect, sourcing, PNP (open); Hall-effect, sinking, NPN (open); each with either flying leads or QD (quick disconnect). Commonly used to send analog signals to PLC (programmable logic controllers), TLL, CMOS circuit or other controller device. These switches are activated by the actuator's magnet.

Switches contain reverse polarity protection. QD cables are shielded; shield should be terminated at flying lead end.

If necessary to remove factory installed switches, be sure to reinstall on the same side of actuator with scored face of switch toward internal magnet.

SPECIFICATIONS

ORDER CODE	REED DC				REED AC		HALL-EFFECT DC			
	R T	R M	B T	B M	C T	C M	T T	T M	K T	K M
LEAD	5m	QD*	5m	QD*	5m	QD*	5m	QD*	5m	QD*
CABLE SHIELDING	Unshielded	Shielded†	Unshielded	Shielded†	Unshielded	Shielded†	Unshielded	Shielded†	Unshielded	Shielded†
SWITCHING LOGIC	"A" Normally Open		"C" Normally Open or Closed		Triac Normally Open		PNP (Sourcing) Normally Open		NPN (Sinking) Normally Open	
MECHANICAL CONTACTS	Single-Pole Single-Throw		Single-Pole Double-Throw		Single-Pole Single-Throw		NO, These Are Solid State Components			
COIL DIRECT	Yes		Yes		Yes		—			
POWER LED	None		None		None		None		None	
SIGNAL LED	Red		None		None		Red		Red	
OPERATING VOLTAGE	200 Vdc max.		120 Vdc max.		120 Vac max.		5 - 25 Vdc			
OUTPUT RATING	—		—		—		25 Vdc, 200mA dc			
OPERATING TIME	0 .6msec max. (including bounce)		0 .7msec max. (including bounce)		—		< 10 micro sec.			
OPERATING TEMPERATURE	-40°F [-40°C] to 158°F [70°C]						0°F [-18°C] to 150°F [66°C]			
RELEASE TIME	1 .0msec. max.		—		—		—			
ON TRIP POINT	—		—		—		150 Gauss maximum			
OFF TRIP POINT	—		—		—		40 Gauss minimum			
**POWER RATING (WATTS)	10 .0 [§]		3 .0 ^{§§}		10 .		5 .			
VOLTAGE DROP	2 .6V typical at 100 mA		NA		—		—			
RESISTANCE	0 . Ω Initial (Max .)		—		—		—			
CURRENT CONSUMPTION	—		—		1 Amp at 86°F [30°C] 0 .5Amp at 140°F [60°C]		200 mA at 25 Vdc			
FREQUENCY	—		—		47 - 63 Hz		—			
CABLE MIN. BEND RADIUS	STATIC	0 .630" [16mm]								
	DYNAMIC	Not Recommended								

⚠ CAUTION: DO NOT OVER TIGHTEN SWITCH HARDWARE WHEN INSTALLING!

⚠ ** WARNING: Do not exceed power rating (Watt = Voltage X Amperage). Permanent damage to sensor will occur.

*QD = Quick Disconnect; Male coupler is located 6" [152mm] from sensor, Female coupler to flying lead (part #2503-1025) distance is 197" [5m] also see Cable Shielding specification above

⚠ REPLACEMENT OF QD SWITCHES MANUFACTURED BEFORE JULY 1, 1997: It will be necessary to replace or rewire the female end coupler.



Reed Switch Life Expectancy: Up to 200,000,000 cycles (depending on load current, duty cycle and environmental conditions)

†Shielded from the female quick disconnect coupler to the flying leads. Shield should be terminated at flying lead end.

§ Maximum current 500mA (not to exceed 10VA) Refer to Temperature vs. Current graph and Voltage Derating graph

§§ Maximum current 250mA (not to exceed 3VA) Refer to Temperature vs. Current graph and Voltage Derating graph

BC2 Switches - ALL Sizes

PERFORMANCE

TEMP. vs CURRENT, DC REED

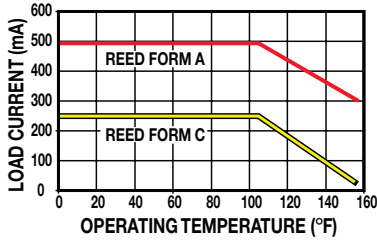

TEMP. vs CURRENT, AC REED

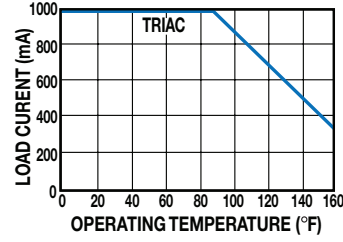

VOLTAGE DERATING, DC REED

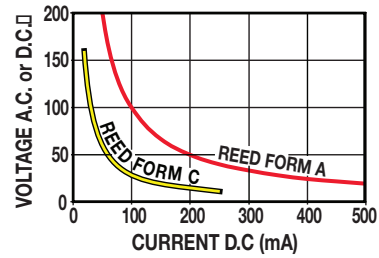

WIRING DIAGRAMS

RT & **R**M DC REED, FORM A

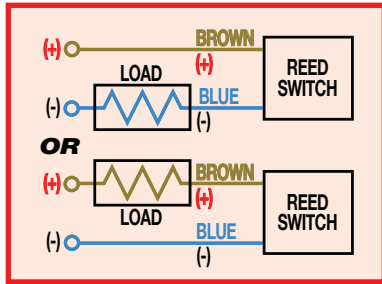

CT & **C**M AC REED, TRIAC

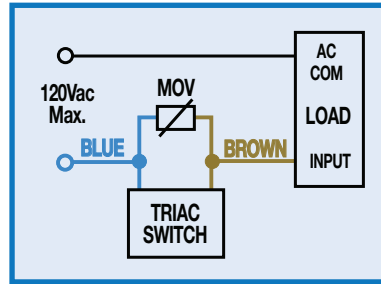

BT & **B**M DC REED, FORM C

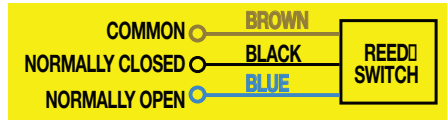

TT & **T**M HALL-EFFECT, SOURCING, PNP

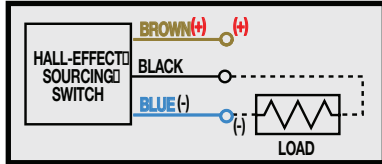

KT & **K**M HALL-EFFECT, SINKING, NPN

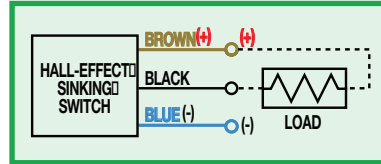

INSTALLATION INFORMATION



⚠ THE NOTCHED FACE OF THE SWITCH INDICATES THE SENSING SURFACE AND MUST FACE TOWARD THE MAGNET.

⚠ HALL-EFFECT SWITCHES ARE NOT AVAILABLE FOR BC205

⚠ Some actuators may require switch mounting on a specific side of the assembly. Call Tolomatic for details.

DIMENSIONS

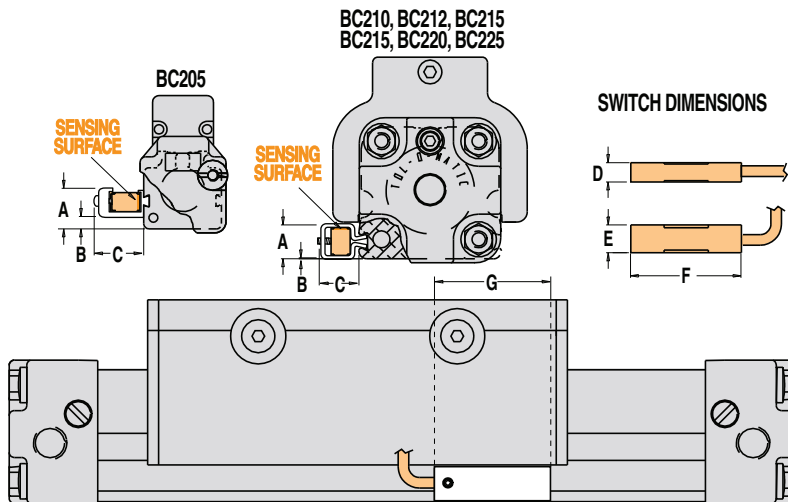

SIZE	BORE	A	B	C	D	E	F	G
05	0.50	0.445	0.157	0.518	0.219	0.315	1.25	1.45
10	1.00	0.383	0.011	0.448	0.219	0.315	1.25	1.45
12	1.25	0.541	0.169	0.448	0.219	0.315	1.25	1.45
15	1.50	0.548	0.161	0.432	0.219	0.315	1.25	1.45
20	2.00	0.732	0.344	0.448	0.219	0.315	1.25	1.45
25	2.50	1.082	0.710	0.432	0.219	0.315	1.25	1.45

Dimensions in inches

SIZE	BORE	A	B	C	D	E	F	G
05	12	11.30	3.99	13.16	5.56	8.00	31.75	36.83
10	25	9.73	0.28	11.38	5.56	8.00	31.75	36.83
12	32	13.74	4.29	11.38	5.56	8.00	31.75	36.83
15	40	13.92	4.09	10.97	5.56	8.00	31.75	36.83
20	50	18.59	8.74	11.38	5.56	8.00	31.75	36.83
25	63	27.48	18.03	10.97	5.56	8.00	31.75	36.83

Dimensions in millimeters

BC2 Shock Absorbers - 10, 12, 15, 20, 25 Sizes

3D CAD available at
www.tolomatic.com



Always use configured CAD solid model
to determine critical dimensions

SHOCK ABSORBERS

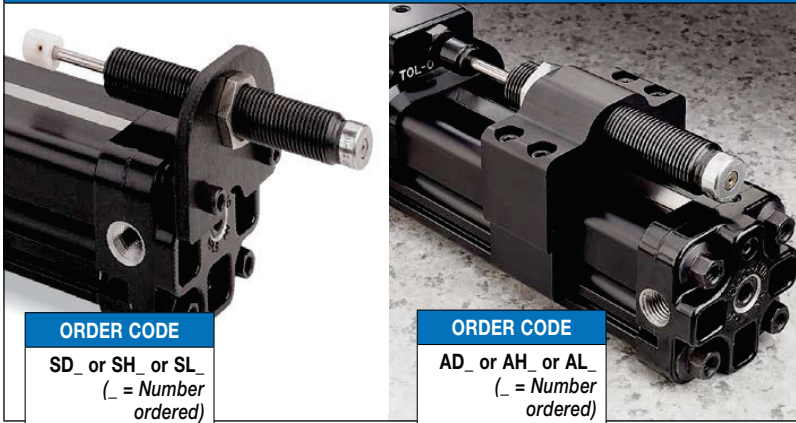

ORDER CODE

SD_ or SH_ or SL_
(_ = Number
ordered)

ORDER CODE

AD_ or AH_ or AL_
(_ = Number
ordered)

Rodless cylinders with standard internal cushion offer an effective method of decelerating loads. However, all Tolomatic rodless cylinders are capable of carrying heavier loads at higher velocities than the cylinder cushion can absorb. Optional shock absorbers can be used to increase the cylinder's life and broaden the application range for the cylinder model you have chosen.

Tolomatic offers two types of shock absorber options for use with rodless cylinders. Standard shock absorbers, which are positioned on the cylinder heads for end-of-stroke deceleration and adjustable shock absorbers which allows the shock to be positioned at any point along the cylinder.

Typical shock absorber life varies between 1-2 million cycles (depending on environment) appropriate preventative maintenance should be considered in high cyclic applications.

NOTE: When 2 shock absorbers are ordered, the unit will be assembled with NO internal cushions.

NOTE: Adjustable shock absorbers will reduce stroke length. To maintain desired stroke length: when ordering increase stroke length by the dimension in the table below for each adjustable shock absorber ordered.

10	12	15	20	25
0.75" [19.0mm]	0.03" [0.7mm]	0.35" [8.9mm]	0.85" [21.6mm]	0.85" [21.6mm]

CAUTION: In applications which result in a load bending moment at deceleration, care should be taken to decelerate the load rather than the carrier of the band cylinder.

DIMENSIONS

STANDARD SHOCK

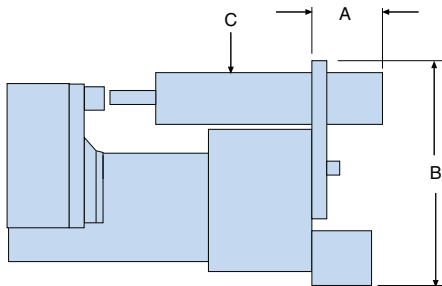

SIZE	BORE	A	B	C (Thread Size)
10	1.00	2.35	2.50	9/16-18 UNF-2B
12	1.25	2.23	3.50	3/4-16 UNF-2B
15	1.50	2.23	4.00	3/4-16 UNF-2B
20	2.00	2.62	4.70	1-12 UNF-2B
25	2.50	1.17	6.00	1-12 UNF-2B

Dimensions in inches

SIZE	BORE	A	B	C (Thread Size)
10	25	59.7	63.5	M14x1.5-6g
12	32	56.6	88.9	M20x1.5-6g
15	40	56.6	101.6	M20x1.5-6g
20	50	66.5	119.4	M25x1.5-6g
25	63	29.7	152.4	M25x1.5-6g

Dimensions in millimeters

ADJUSTABLE POSITION SHOCK

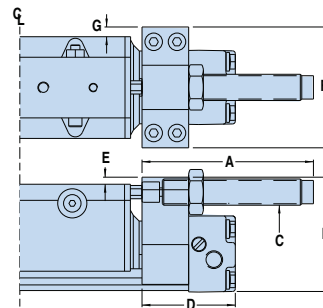

SIZE	BORE	A	B	C (Thread Size)	D	E	F	G
10	1.00	3.68	2.45	9/16-18 UNF-2B	2.00	0.15	2.59	0.21
12	1.25	4.39	3.19	3/4-16 UNF-2B	2.25	0.13	2.82	0
15	1.50	4.39	3.62	3/4-16 UNF-2B	2.50	0.05	3.50	0
20	2.00	4.75	4.60	1-12 UNF-2B	3.13	0.16	4.44	0
25	2.50	4.75	5.63	1-12 UNF-2B	4.47	0.17	5.63	0

Dimensions in inches

SIZE	BORE	A	B	C (Thread Size)	D	E	F	G
10	25	93.5	62.2	M14x1.5-6g	50.8	3.8	65.8	5.3
12	32	111.5	81.0	M20x1.5-6g	57.2	3.3	71.6	0
15	40	111.5	92.0	M20x1.5-6g	63.5	1.3	88.9	0
20	50	120.7	116.8	M25x1.5-6g	79.5	4.1	112.8	0
25	63	120.7	143.0	M25x1.5-6g	113.5	4.3	143.0	0

Dimensions in millimeters

BC2 Shock Absorbers - 10, 12, 15, 20, 25 Sizes: PERFORMANCE

VELOCITY vs LOAD

BC210

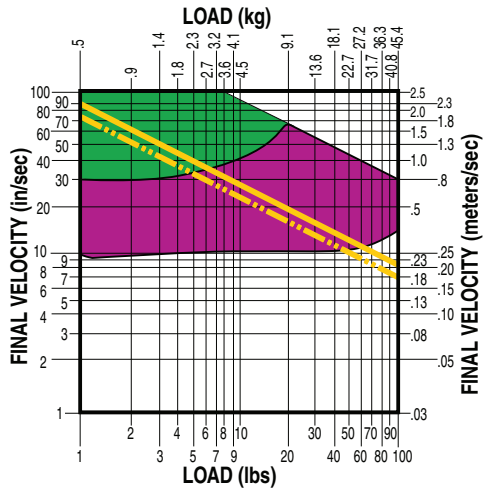

BC212

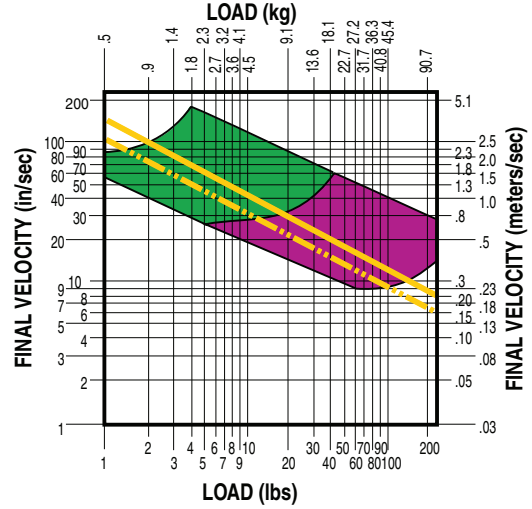

BC215

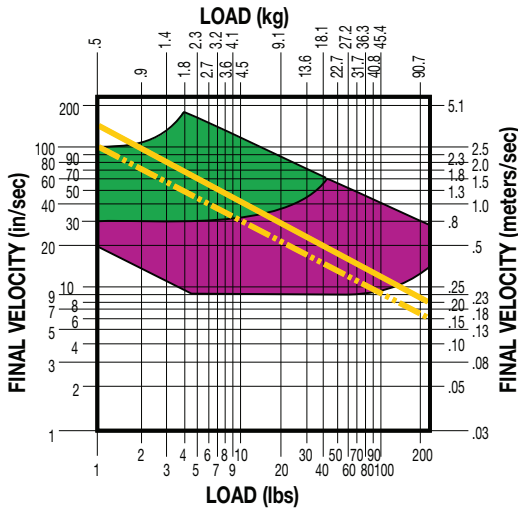

BC220

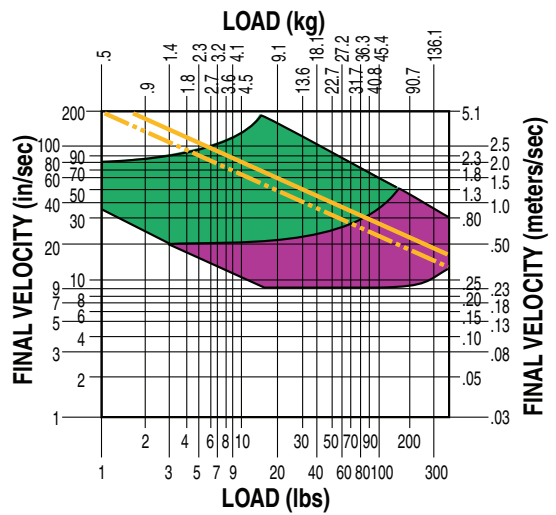

BC225

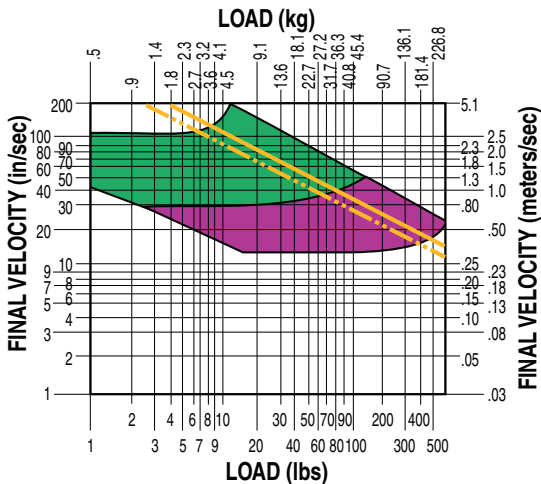

- LIGHT DUTY (Light load/High velocity)
- HEAVY DUTY (Heavy load/Low velocity)
- AIR CUSHION DATA

NOTE: If final (or impact) velocity cannot be calculated directly, a reasonable guideline to use is 2 x average velocity.

ART MXP BC2 BC3 BC4 LS MG CC PB ENGR

Application Data Worksheet

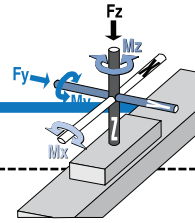

ABT
MXP
BC2
BC3
BC4
LS
MG
CC
PB
ENGR

STROKE LENGTH _____
 inch (S&K) (U.S. Standard) millimeters (Metric)

AVAILABLE AIR PRESSURE _____
 PSI (U.S. Standard) bar (Metric)

REQUIRED THRUST FORCE _____
 lbf (U.S. Standard) N (Metric)

LOAD _____
 lb (U.S. Standard) kg (Metric)

LOAD CENTER OF GRAVITY DISTANCE TO CARRIER CENTER
 d_x _____
 d_y _____
 d_z _____
 inch (U.S. Standard) millimeters (Metric)

ORIENTATION

Horizontal Side Horizontal Down

Vertical Angled α _____

OTHER ISSUES: (i.e. Environment, Temperature, Contamination, etc.) _____

Contact information: _____



Fax (1-763-478-8080) or call Tolomatic (1-800-328-2174) with the above information. We will provide any assistance needed to determine the proper actuator.

Rodless Cylinder Selection Guidelines - BC2, BC3, BC4, LS - All Sizes

PROVIDING LOAD GUIDANCE AND SUPPORT

The process of selecting a load bearing actuator for a given application can be complex. It is highly recommended that you contact Tolomatic or a Tolomatic Distributor for assistance in selecting the best actuator for your application. The following overview of the selection guidelines are for educational purposes only.

1 COMPILE APPLICATION REQUIREMENTS

To determine the appropriate Band Cylinder or Linear Slide model for an application, compile the following information:

- Available pressure (PSI)
- Weight of load (lbs or kg)
- Orientation of load (lbs or kgs)
- Velocity of load (in/sec or mm/sec)
- Stroke length (in or mm)

HINT: Use Tolomatic sizing and selection software, download at: tolomatic.com

2 SELECT CYLINDER SIZE

- Consult the Theoretical Force vs. Pressure charts.
- Cross-reference the load force (or load weight if force is not known) and the available operating pressure. If the intersection falls below the diagonal line, and if moments do not exceed maximum values listed for that model (see Step 3), the actuator will accommodate the application.

If the intersection is above the diagonal line, a larger cylinder bore size should be considered.

NOTE: Additional force may be required to obtain the necessary acceleration for vertical or horizontal loads.

3 DETERMINE NATURE OF LOAD AND THE EFFECT OF BENDING MOMENTS

If the cylinder will guide and support a load located directly over the center of carrier, bending moments will not be a factor in the cylinder selection.

NOTE: The maximum load "L" must not exceed the capacity limits of the cylinder selected.

- Bending Moments

For off center or side loads, determine the distance from the center of mass of the load to the center of the carrier bracket. This measurement is needed to calculate the torque for bending moments. (Refer to Bending Moment chart for each model.)

Should the resulting maximum bending moment exceed figures indicated on the chart, external guides, auxiliary carrier/s or a larger cylinder should be considered.

- Auxiliary Carrier Bending Moments

The auxiliary carrier option (available on most models) increases load carrying capacity and bending moments. Auxiliary carriers can be ordered with or without an internal piston. (Auxiliary

carriers without a piston have no internal cushion on the cylinder end closest to the auxiliary carrier.)

IMPORTANT: When ordering, determine the working stroke, then the minimum distance required between carriers (dimension "D" in Auxiliary Carrier Bending Moments chart). When ordered, Tolomatic's configurator will calculate the overall length of the actuator.

NOTE: breakaway pressure will increase when using auxiliary carriers.

4 DETERMINE INTERNAL CUSHION CAPACITY

- Consult the Cushion Data chart for the model selected. The velocities listed on the cushion charts are final or cushion impact velocities. On applications where the internal cushions or bumpers are to be used, be sure the actual, final or impact velocity is known. If the velocity is not known, use of limit switches with valve deceleration circuits or shock absorbers should be considered. NOTE: The BC205 uses external bumpers in place of internal cushions, LS05 & LS10 do not have cushions or bumpers.
- Cross-reference the final velocity and weight of the load. If the intersection is below the diagonal lines, the internal cushions on the actuator may be used. If the point falls above the dashed diagonal line or if the velocity is not known, use deceleration circuits, external shock absorbers or select a

larger cylinder with greater cushion capacity. On high-cyclic applications, use of external stops is strongly recommended.

5 DETERMINE TUBE SUPPORT REQUIREMENTS

- Consult the Tube Support chart for the model selected.
- Cross reference the load weight and maximum distance between supports.

6 CONSIDER OPTIONS

- Switches— dc Reed, Hall-effect or ac Triac

Band Cylinders and Linear Slides each have different standard features and options. Check the options section for the actuator you have selected.

- Shock Absorbers— if needed.
- Foot Mounting Kits
- Floating Mount Bracket – use when lack of parallelism occurs between the cylinder and an external guided and supported load.
- Single End Porting (BC3, BC4)
- Long Carrier (BC4)
- Proximity Sensors (LS)
- Dual 180° Carrier (BC3)

Application Guidelines

The following conditional statements are intended as general guidelines for use of Tolomatic actuators. Since all applications have their own specific operating requirements, consult Tolomatic, Inc. or your local Tolomatic distributor if an application is unconventional or if questions arise regarding the selection process.

CUSHION NEEDLE ADJUSTMENT (BC2, BC3, BC4, CC, SA, DP, TC ONLY)



Adjust the cushion needles in the cylinder heads carefully to obtain a smooth, hesitation free deceleration for your particular application. If there are questions on proper adjustment, please consult Tolomatic, Inc.

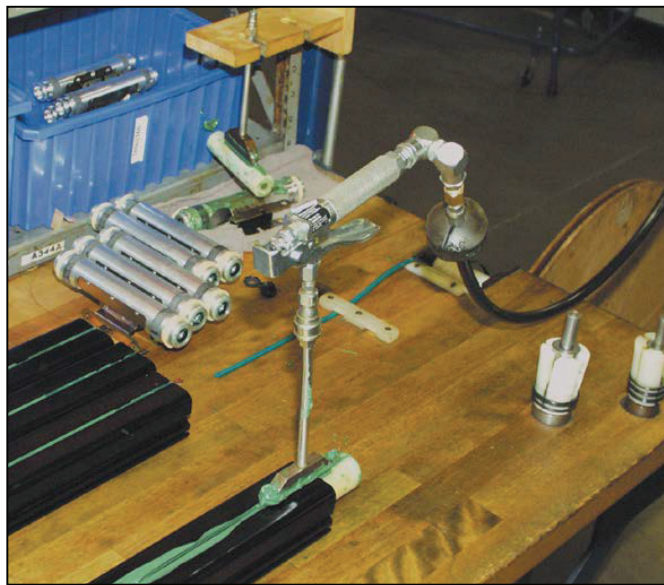

LUBRICATION GUIDELINES

All Tolomatic actuators (except Cable Cylinders) are prelubricated at the factory. To ensure maximum actuator life, the following guidelines should be followed.

• Filtration

We recommend the use of dry, filtered air in our products. "Filtered air" means a level of 10 Micron or less. "Dry" means air should be free of appreciable amounts of moisture. Regular maintenance of installed

filters will generally keep excess moisture in check.

• External Lubricators (optional)

The factory prelubrication of Tolomatic actuators will provide optimal performance without the use of external lubrication. However, external lubricators can further extend service life of pneumatic actuators if the supply is kept constant.

Oil lubricators, (mist or drop) should supply a minimum of 1 drop per 20 standard cubic feet per minute to the

cylinder. As a rule of thumb, double that rate if water in the system is suspected. Demanding conditions may require more lubricant.

If lubricators are used, we recommend a non-detergent, 20cP @ 140°F 10-weight lubricant. Optimum conditions for standard cylinder operation are +32° to +150°F (+0° to 65 .5°C)

NOTE: Use of external lubricators may wash away the factory installed lubrication. External lubricants must be maintained in a constant supply or the results will be a dry actuator prone to premature wear.

• Sanitary Environments

Oil mist lubricators must dispense "Food Grade" lubricants to the air supply. Use fluids with ORAL LD50 toxicity ratings of 35 or higher such as Multitherm® PG-1 or equivalent. Demanding conditions can require a review of the application.

FINAL VELOCITY CALCULATION

Velocity calculations for all rodless cylinders need to differentiate between final velocity and average velocity. For example: Stroking a 100-inch BC3 model in one second yields an average velocity of 100 inches per second. To properly determine the inertial forces for cushioning, it is important to know the

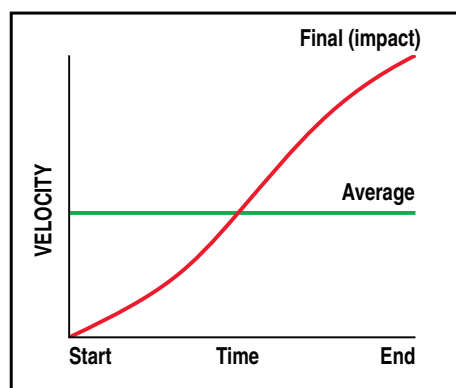

final (or impact) velocity. Rodless cylinders accelerate and decelerate at each end of the stroke. Therefore this acceleration must be considered (see diagram).

If final (or impact) velocity cannot be calculated directly, a reasonable guideline is to use 2 x average velocity.

BC2 Service Parts Ordering - ALL Sizes

Inch (U.S. Standard) SIZE	05	10	12	15	20	25
Aux. Carrier Assembly (w/piston) (each)	NA	0510-9057	0512-9057	0515-9057	0520-9057	0525-9057
Aux. Carrier Assembly (wo/piston) (each)	NA	0510-9095	0512-9095	0515-9095	0520-9095	0525-9095
Floating Mount Bracket Kit	0905-9115	0510-9007	0512-9007	0515-9007	0520-9007	0525-9007
Foot Mount Kit¹	0905-9010	0510-9125	0512-9125	0515-9125	0520-9125	0525-9125
Shock Field Retrofit Kit – Heavy Dut ^{2,8}	NA	0510-9090	0512-9090	0515-9090	0520-9090	0525-9090
Shock Field Retrofit Kit – Light Dut ^{2,8}	NA	0510-9091	0512-9091	0515-9091	0520-9091	0525-9091
Shock Field Mount Kit (Hardware Only)^{3,8}	NA	0510-9092	0512-9092	0515-9092	0520-9092	0525-9092
Adj. Shock Field Retrofit Kit – Heavy Dut ²	NA	0510-9048	0512-9011	0515-9011	0520-9011	0525-9011
Adj. Shock Field Retrofit Kit – Light Dut ²	NA	0510-9049	0512-9012	0515-9012	0520-9012	0525-9012
Adj. Shock Field Mount Kit (Hardware Only)³	NA	0510-9072	0512-9072	0515-9072	0520-9072	0525-9013
Tube Supports⁴	0905-1034	4510-1010	4512-1010	4515-1010	4520-1010	4525-1010
Repair Kits^{5,6,7}	RKBC205NP	RKBC210NP	RKBC212NP	RKBC215NP	RKBC220NP	RKBC225NP

Metric SIZE	05	10	12	15	20	25
Aux. Carrier Assembly (w/piston) (each)	NA	4510-9057	4512-9057	4515-9057	4520-9057	4525-9057
Aux. Carrier Assembly (wo/piston) (each)	NA	4510-9095	4512-9095	4515-9095	4520-9095	4525-9095
Floating Mount Bracket Kit	4905-9115	4510-9007	4512-9007	4515-9007	4520-9007	4525-9007
Foot Mount Kit¹	4905-9010	4510-9125	4512-9125	4515-9125	4520-9125	4525-9125
Shock Field Retrofit Kit – Heavy Dut ^{2,8}	NA	4510-9090	4512-9090	4515-9090	4520-9090	4525-9090
Shock Field Retrofit Kit – Light Dut ^{2,8}	NA	4510-9091	4512-9091	4515-9091	4520-9091	4525-9091
Shock Field Mount Kit (Hardware Only)^{3,8}	NA	4510-9092	4512-9092	4515-9092	4520-9092	4525-9092
Adj. Shock Field Retrofit Kit – Heavy Dut ²	NA	4510-9013	4512-9013	4515-9013	4520-9013	4525-9013
Adj. Shock Field Retrofit Kit – Light Dut ²	NA	4510-9014	4512-9014	4515-9014	4520-9014	4525-9014
Adj. Shock Field Mount Kit (Hardware Only)³	NA	4510-9025	4512-9025	4515-9025	4520-9025	4525-9025
Tube Supports⁴	0905-1034	4510-1010	4512-1010	4515-1010	4520-1010	4525-1010
Repair Kits^{5,6,7}	RKBC205TP(GP)	RKBC210TP(GP)	RKBC212TP(GP)	RKBC215TP(GP)	RKBC220TP(GP)	RKBC225TP(GP)

CONFIG. CODE ORDERING	
Mounting Hardware & FE conn. included	
DESCRIPTION	CODE
Switch Kit, Reed, Form C, 5m	BT
Switch Kit, Reed, Form C, Male Conn.	BM
Switch Kit, Reed, Form A, 5m	RT
Switch Kit, Reed, Form A, Male Conn.	RM
Switch Kit, Triac, 5m	CT
Switch Kit, Triac, Male Conn.	CM
Switch Kit, Hall-effect, Sinking, 5m	KT
Switch Kit, Hall-effect, Sinking, Male Conn.	KM
Switch Kit, Hall-effect, Sourcing, 5m	TT
Switch Kit, Hall-effect, Sourcing, Male Conn.	TM

NOTE: When kit is ordered female connector & all mounting hardware is included

Switch Ordering NOTES:

To order field retrofit switch and hardware kits for all Tolomatic actuators: SW (Then the model and bore size, and type of switch required)

Example: SWBC215RT

(Hardware and Form A Reed switch with 5 meter lead for 1.5" bore BC2 band cylinder)



Service Parts Ordering NOTES:

- Foot Mount Kit contains two foot mount brackets and mounting hardware
- Shock Field Retrofit Kit contains one Shock Absorber and mounting hardware
- Shock Field Mount Kit contains one set of mounting hardware only
- A minimum of 2 (two) Tube Supports required per cylinder
- Repair Kit for 05 size contains O-rings, U-Cups, End Caps, Wear Strips, Band Inserts, Spring Clamps, Sealing Band, Dust Band and Shock Absorbing Pads
- Repair Kit for 10, 12, 15, 20 & 25 size contains End Caps, Bearing Rods, O-rings, U-cups, Wear Rings, Cushion Seals, Band Inserts, Spring Clamps, Sealing Band and Dust Band.
- When ordering repair kits, specify stroke as "SK" then indicate the desired length in decimal inches after the order code indicated above. EXAMPLE: RKBC210SK10.00
- Standard end-of-stroke shock absorbers are designed to operate without the assistance of the standard band cylinder cushion. To ensure proper shock absorber performance, make sure the air cushion is disabled.

NA = Not Available

BC2 Ordering - ALL Sizes

MODEL, BORE, STROKE **OPTIONS**

BC2 10 NP SK1000.250 DW6.0 TS3 FM2 SH2 BM2

MODEL & MOUNTING
BC2 BC2 Band Cylinder

BORE SIZE

05	0.50" (12mm)
10	1.00" (25mm)
12	1.25" (32mm)
15	1.50" (40mm)
20	2.00" (50mm)
25	2.50" (63mm)

MOUNTING & PORTS

NP US standard mounting & NPT ports

TP† Metric mounting with metric taper port

GP† Metric mounting with metric parallel port

† The metric version provides metric tapped holes for mounting of the load to the carrier and of the actuator to mounting surfaces & metric ports

STROKE LENGTH & MOUNTING TYPE

SK ___ Stroke, enter desired stroke length in inches

SM† ___ Stroke, enter desired stroke length in millimeters

NOTE: Actuator mounting threads and mounting fasteners will be either inch or metric; depending on how stroke length is indicated.

SK = inch mounting
SM = metric mounting

MAXIMUM STROKE

SIZE	...SK	...SM
	in	mm
05	171	4,343
10	350	8,890
12	288	7,315
15	298	7,569
20	274	6,959
25	163	4,140

Not all codes listed are compatible with all options. Contact Tolomatic with any questions.

AUXILIARY CARRIER (BC2_14)

DW Auxiliary carrier With piston & "D" distance

DO Auxiliary carrier Without piston & "D" distance

--- "D" Distance between carriers "D" Distance between carriers in inches (**SK**) or millimeters (**SM**)

(Same unit of measure as stroke length is required)

⊗ Not available for 05 size

MINIMUM "D" DISTANCE BETWEEN CARRIERS

	(DO) w/o Piston		(DW) w/ Piston	
	in	mm	in	mm
10	5.07	129	5.07	129
12	5.17	131	6.85	174
15	6.46	164	8.07	205
20	8.10	206	8.10	206
25	9.62	244	11.06	281

*When ordering auxiliary carrier option, enter the distance required between carriers. The configurator will calculate the overall length of the actuator.

TUBE SUPPORTS (BC2_16)

TS Tube Support & number required

FOOT MOUNT (BC2_17)

FM Foot Mount & number required (1 or 2)

FLOATING MOUNT (BC2_18)

FL Floating Mount Bracket

⊗ Not compatible with shock absorbers

PORTING OPTION

HDL 4-Ported Head - Left End

HDR 4-Ported Head - Right End

HDB 4-Ported Head - Both Ends

⊗ Not available for 05 size

SHOCK ABSORBERS (BC2_22)

SD Shock hardware Only and number required

SH Shock, Heavy duty and number required

SL Shock, Light duty and number required

***AD** Adjustable shock hardware Only and number required

***AH** Adjustable shock, Heavy duty and number required

***AL** Adjustable shock, Light duty and number required

⊗ Not available for 05 size

*NOTE: Adjustable Shock will reduce working stroke (see page BC2_22)

SWITCHES (BC2_20)

TYPE		QUICK-DISCONNECT	CODE	QUANTITY	LEAD LENGTH
REED	Form A	QD	RM	After code enter quantity desired	5 meters
		no	RT		
Form C	QD	BM			
	no	BT			
HALL-EFFECT	Sinking	QD	*KM		
		no	*KT		
	Sourcing	QD	*TM		
		no	*TT		
TRIAC	QD	CM			
	no	CT			

MDR Dual Magnet (Reed, Hall-effect, Triac)

*⊗ Not available for 05 size

