

DSM11099H-18275

Step Angle		1.8°			
Step Angle Accuracy		±5			
Holding Torque (Bipolar)		11.5Nm		8.2 ft-lbs	
Current (RMS)		Bipolar Parallel	Bipolar Series	Unipolar	
		5.5 A	2.75 A	3.8 A	
Winding Resistance (Ω)		0.9			
Winding Inductance (mH)		12.5			
Detent Torque					
Rotor Inertia (kgcm <sup>2</sup> )		5.5			
Insulation Class		Class B, 100MΩ			
Mass		5kg			
Bearings		Front 6304ZZ (Japan)			
Direction of Rotation	Step	Red	Yellow	White	Orange
		Blue	Black	Brown	Green
<div style="display: flex; justify-content: space-around;"> <div style="text-align: center;"> <p>↑</p> <p><b>CW</b></p> <p>↑</p> </div> <div style="text-align: center;"> <p>↓</p> <p><b>CCW</b></p> <p>↓</p> </div> </div>	1	+	-	+	-
	2	+	-	OFF	OFF
	3	+	-	-	+
	4	OFF	OFF	-	+
	5	-	+	-	+
	6	-	+	OFF	OFF
	7	-	+	+	-
	8	OFF	OFF	+	-
Sequence shown is for half-step excitation. For full step excitation energise as steps 1,3,5,7					

Label Details

DSM11099H-18275
BIPOLAR PLL 5.5A
BIPOLAR SER 2.75A
UNIPOLAR 3.8A
Made in China

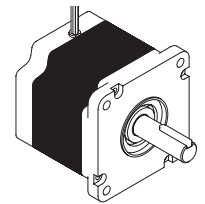
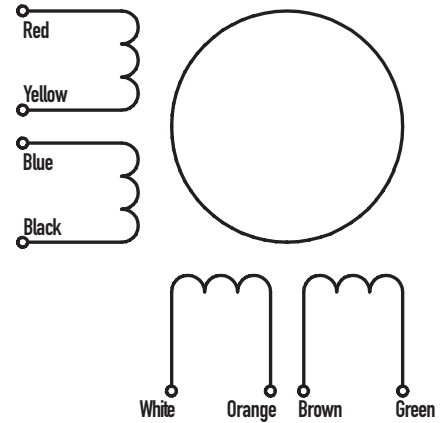

1:2

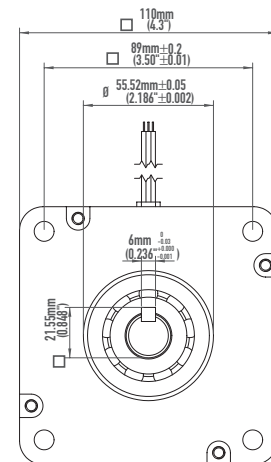
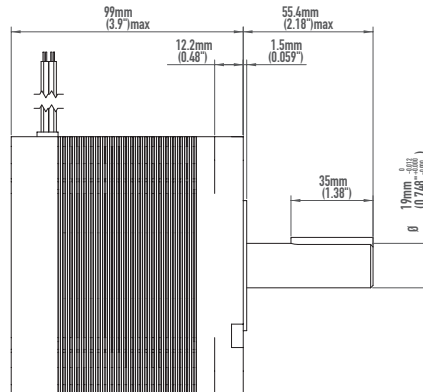
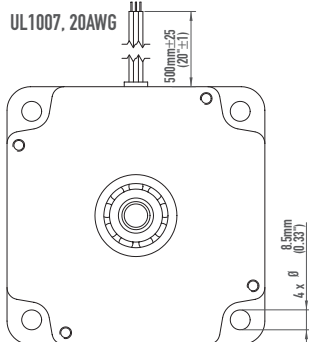

## DSM110150-18325

Step Angle		1.8°			
Step Angle Accuracy		±5			
Holding Torque (Bipolar)		21Nm		15ft-lbs	
Current (RMS)		Bipolar Parallel	Bipolar Series	Unipolar	
		6.5 A	3.25 A	4.6 A	
Winding Resistance (Ω)		0.72			
Winding Inductance (mH)		12.8			
Detent Torque					
Rotor Inertia (kgcm <sup>2</sup> )		10.9			
Insulation Class		Class B, 100MΩ			
Mass		8.4kg			
Bearings		Front 6304ZZ (Japan)			
Direction of Rotation	Step	Red	Yellow	White	Orange
		Blue	Black	Brown	Green
<div style="display: flex; justify-content: space-around;"> <div style="text-align: center;"> <p>↑</p> <p><b>CW</b></p> <p>↑</p> </div> <div style="text-align: center;"> <p>↓</p> <p><b>CCW</b></p> <p>↓</p> </div> </div>	1	+	-	+	-
	2	+	-	OFF	OFF
	3	+	-	-	+
	4	OFF	OFF	-	+
	5	-	+	-	+
	6	-	+	OFF	OFF
	7	-	+	+	-
	8	OFF	OFF	+	-
Sequence shown is for half-step excitation. For full step excitation energise as steps 1,3,5,7					

Label Details

DSM110150H-18325
BIPOLAR PLL 6.5A
BIPOLAR SER 3.25A
UNIPOLAR 4.6A
Made in China

