



DIRECT DRIVE TECHNOLOGY
Product Catalogue
VERSION 4.1.1



PDDR SERIES
DIRECT DRIVE ROTARY MOTOR



PDDR SERIES

DIRECT DRIVE ROTARY MOTOR



Optimally designed for high speed precise rotary applications

The PDDR's built in hi-res encoder design enables high performance resolution, repeatability, accuracy motion profile with direct mounting of rotary table/load without additional mechanical power transmission mechanisms that eventually lead to accuracy loss due to gearing backlash, slippage or coupling compliance errors. This results in a compact size solution which allows for significant amount of space saving and simplifies machine design process.

The PDDR's special iron core construction design enables the motor to achieve a very high torque with almost negligible cogging forces, which is most favorable for constant speed precision applications.

- Excellent for dynamic motion profile
- High positional repeatability and accuracy
- Compact design
- High torque Vs size ratio
- Optimal high and low speed control
- Zero maintenance
- Easy integration

**Technical specifications subject to change without prior notice*

APPLICATION

- Radars
- Scanners
- Rotary indexing table
- Robots
- Lathes
- Wafer handling
- DVD handler
- Packaging
- Turret inspection station
- Direction change conveyors
- General automation

PART NUMBERING SYSTEM

06

PDDR 110	07
PDDR 150	09
PDDR 150-T	10
PDDR 160	12
PDDR 240	14
PDDR 300	16
PDDR 490	18
Cable Option	20

HIGH RPM + Torque + Accuracy

High speed precise rotary motion systems

Model	Outer Diameter (mm)	Continuous Torque (N.m)	Peak Torque (N.m)	Continuous Current (A)	Peak Current (A)	Max Speed (RPS)
PDDR110-06-I	110	2.0	6.0	1.6	4.7	10.0
PDDR110-12-I	110	4.0	12.0	1.6	4.7	8.0
PDDR150-T-I	150	1.4	4.3	1.7	5.1	10.0
PDDR150-15-O	152	5.2	15.7	2.5	7.6	5.0
PDDR150-30-O	152	10.7	32.2	5.2	15.7	5.0
PDDR150-50-O	152	18.1	54.4	5.2	15.7	5.0
PDDR150-80-O	152	28.9	86.6	5.2	15.7	5.0
PDDR160-40-I	160	13.3	40.0	6.1	18.2	8.0
PDDR160-80-I	160	27.0	81.0	12.7	38.2	9.0
PDDR240-30-I	240	9.8	29.5	3.4	10.2	5.0
PDDR240-80-I	240	25.2	75.5	4.8	14.4	4.5
PDDR240-132-I	240	41.0	122.9	4.5	13.6	2.8
PDDR300-150-I	300	49.8	149.5	6.6	19.9	2.9
PDDR300-300-I	300	99.9	299.7	12.7	38.2	3.0
PDDR300-450-I	300	150.3	450.9	12.7	38.2	2.0
PDDR490-600-I	490	200.0	540.0	14.8	49.6	2.3
PDDR490-900-I	490	300.0	780.0	14.8	49.6	1.4
PDDR490-1200-I	490	400.0	1090.0	14.8	49.6	1.0

PART NUMBERING SYSTEM

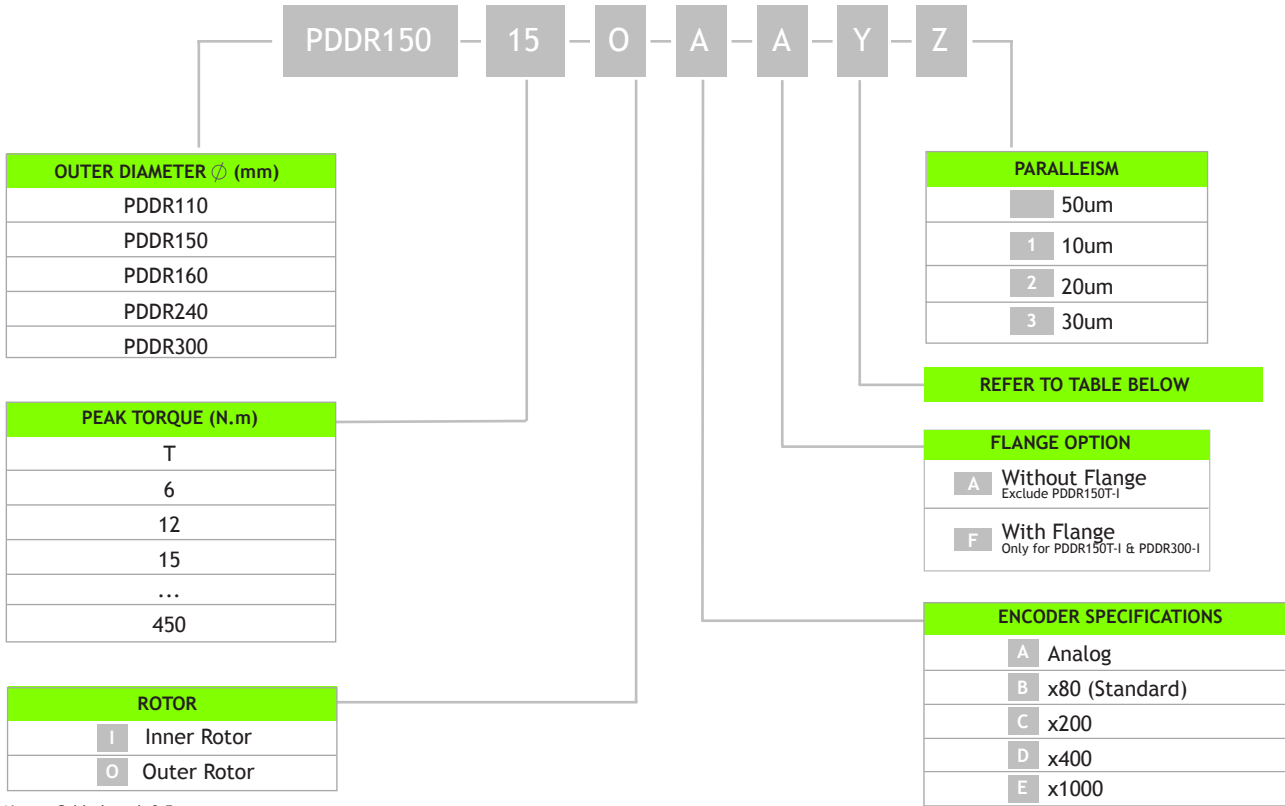

Notes: Cable length 0.5m

DXB/BT
 PIX
 PSM/PSME
 CVC
 CVCA
 RVCA
PDDR
 PCA
 PWA
 PLA
 PDAB
 PIAB
 OCTO
 PRG
 LINEAR ENCODER
 SERVO AMPLIFIER

			PDDR150-15-O-A-A-Y (Select one option)												
			Accuracy												
			+/- 30 arcsec					+/- 15 arcsec							
			Run-out	40 μ m	30 μ m	15 μ m	20 μ m	10 μ m	5 μ m	40 μ m	30 μ m	15 μ m	20 μ m	10 μ m	5 μ m
Series		Flange Option													
PDDR110	PDDR110-06-I	A					00	01	02				10	11	12
	PDDR110-12-I	A					00	01	02				10	11	12
PDDR150-T	PDDR150-T-I	F					00	01	02				10	11	12
PDDR150	PDDR150-15-O	A					00	01					10	11	
	PDDR150-30-O	A					00	01	02				10	11	12
	PDDR150-50-O	A					00	01	02				10	11	12
	PDDR150-80-O	A					00	01	02				10	11	12
PDDR160 (Cable Bottom)	PDDR160-40-I	A					00	01	02				10	11	12
	PDDR160-80-I	A					00	01	02				10	11	12
PDDR160 (Cable Side)	PDDR160-40-I	A					20	21	02				30	31	32
	PDDR160-80-I	A					20	21	02				30	31	32
PDDR240	PDDR240-30-I	A					00	01	02				10	11	12
	PDDR240-80-I	A					00	01	02				10	11	12
	PDDR240-132-I	A					00	01	02				10	11	12
PDDR300 (Cable Side)	PDDR300-150-I	A & F		00	01				02		10	11			12
	PDDR300-300-I	A & F		00	01				02		10	11			12
	PDDR300-450-I	A & F		00	01				02		10	11			12
PDDR300 (Cable Bottom)	PDDR300-150-I	A		20	21				22		30	31			32
	PDDR300-300-I	A		20	21				22		30	31			32
	PDDR300-450-I	A		20	21				22		30	31			32
PDDR490	PDDR490-600-I	A	00				01	02		10			11	12	
	PDDR490-900-I	A	00				01	02		10			11	12	
	PDDR490-1200-I	A	00				01	02		10			11	12	

FORCE CHART FOR PDDR MOTOR

Force Chart For PDDR Motors

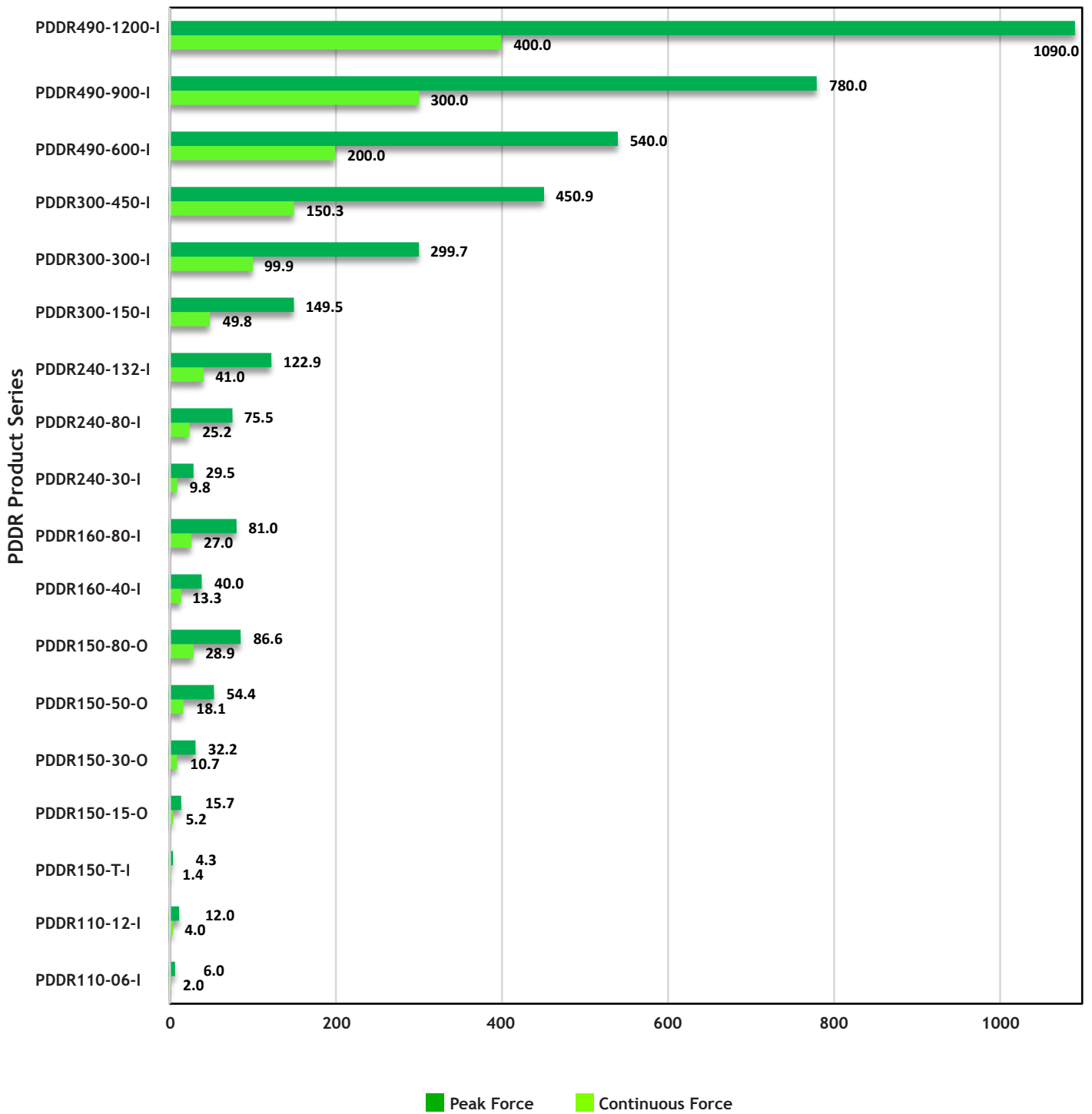

PDDR SERIES

DIRECT DRIVE ROTARY MOTOR

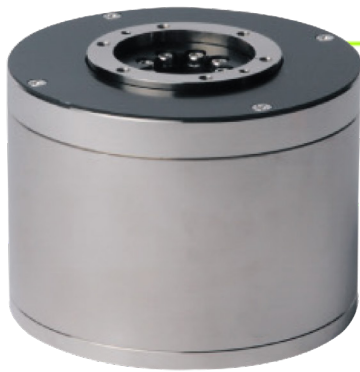

PDDR110

- High RPM, speed and precision
- Peak torque 12Nm

SPECIFICATION		MODEL				
		PDDR110-06-I		PDDR110-12-I		
Performance	Unit					
Peak Torque	N.m	6.0		12.0		
Continuous Torque @ 100°C*	N.m	2.0		4.0		
Peak Power @ 100°C	W	227.7		395.8		
Continuous Power @ 100°C*	W	25.3		44.0		
Electrical						
Peak Current	Apk	4.7				
Continuous Current @ 100°C*	Apk	1.6				
Continuous Stall Current @ 100°C*	Arms	1.1				
Torque Constant	N.m/Apk	1.3		2.5		
Back EMF Constant	Vpk/rad/s	1.4		3.0		
Resistance L-L @ 25°C	Ohm	10.7		18.6		
Resistance L-L @ 100°C	Ohm	13.9		24.2		
Inductance L-L @ 1kHz	mH	18.9		37.8		
Motor Constant @ 100°C	N.m//W	0.4		0.7		
Max. Terminal Voltage	Vdc	400.0				
Thermal						
Thermal Resistance @ 100°C	°C/W	2.96		1.71		
Max. Winding Temperature	°C	120.0				
Mechanical						
Rotor Inertia	kg.m ²	0.0007		0.0012		
Motor Weight	kg	3.9		5.4		
Number of Pole Pairs	N-S	10.0				
Max. Speed*	RPS	10.0		8.0		
Max. Axial Load	kg	90.0				
Max. Moment Load	N.m	12.0				
Axial Run-out (no load)**	um	20/10/5				
Radial Run-out (no load)**	um	20/10/5				
Parallelism****	um	50/30/20				
Resolution (after quadrature)	CPR	A	B(x80)	C (x200)	D(x400)	E(x1000)
		6,480	518,400	1,296,000	2,592,000	6,480,00
Repeatability**	arcsec	+/-2.5				
Accuracy	arcsec	+/-30 / +/-15				

Notes:

1. Apk = 1.414 * Arms; Vpk = 1.414 * Vrms.
2. * Ambient temperature 25°C, heat dissipation by natural convection, without heat sink attached.
3. Specifications tolerance : ±10%.
4. ** Depend on encoder resolution.
5. *** Standard run-out 20um. Contact PBA for 10um and 5um.
6. **** Standard parallelism 50um. Contact PBA for 30um and 20um.
7. Peak force and current : 4% duty ratio and 1 second duration.
8. Specifications are subject to change without prior notice.

DXB/BT
PIX
PSM/PSME
CVC
CVCA
RVCA
PDDR
PCA
PWA
PLA
PDAB
PIAB
OCTO
PRG
LINEAR ENCODER
SERVO AMPLIFIER

- DXB/BT
- PIX
- PSM/PSME
- CVC
- CVCA
- RVCA
- PDDR**
- PCA
- PVA
- PLA
- PDAB
- PIAB
- OCTO
- PRG
- LINEAR ENCODER
- SERVO AMPLIFIER

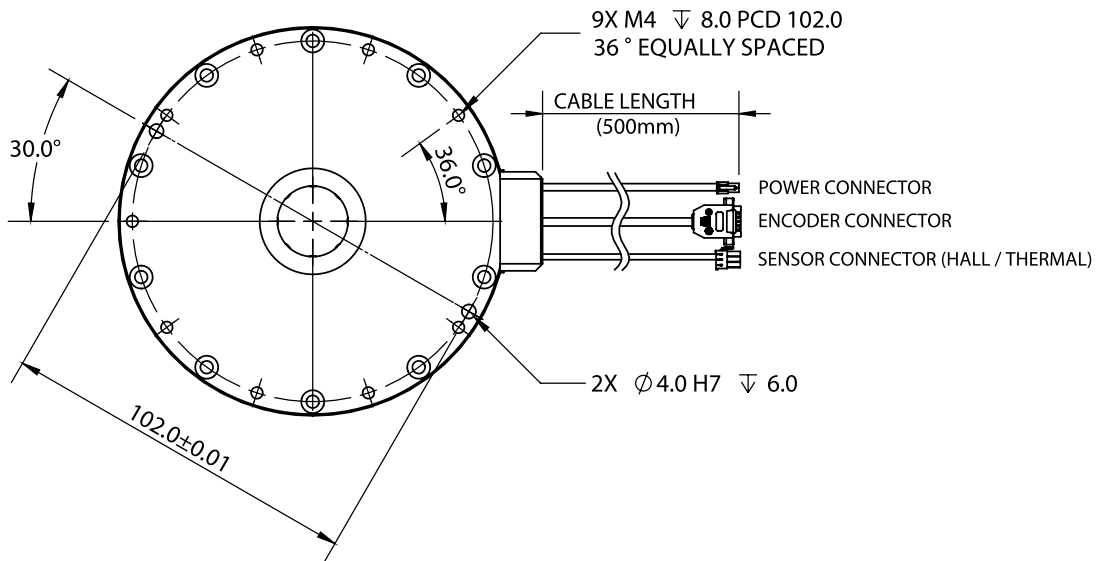
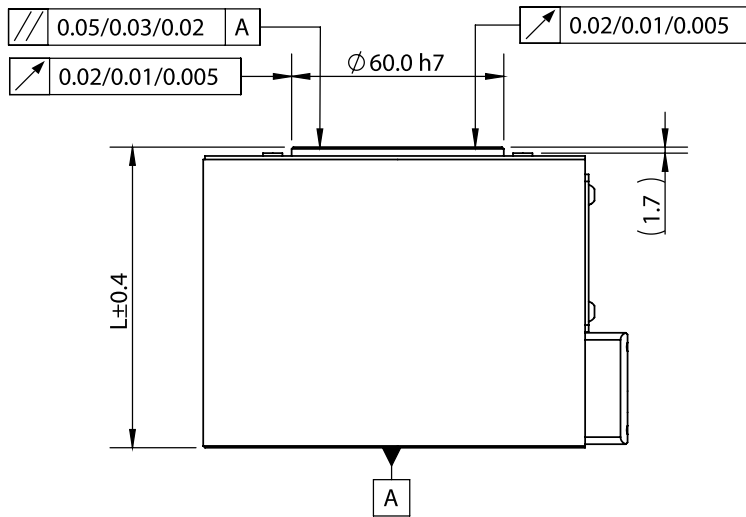
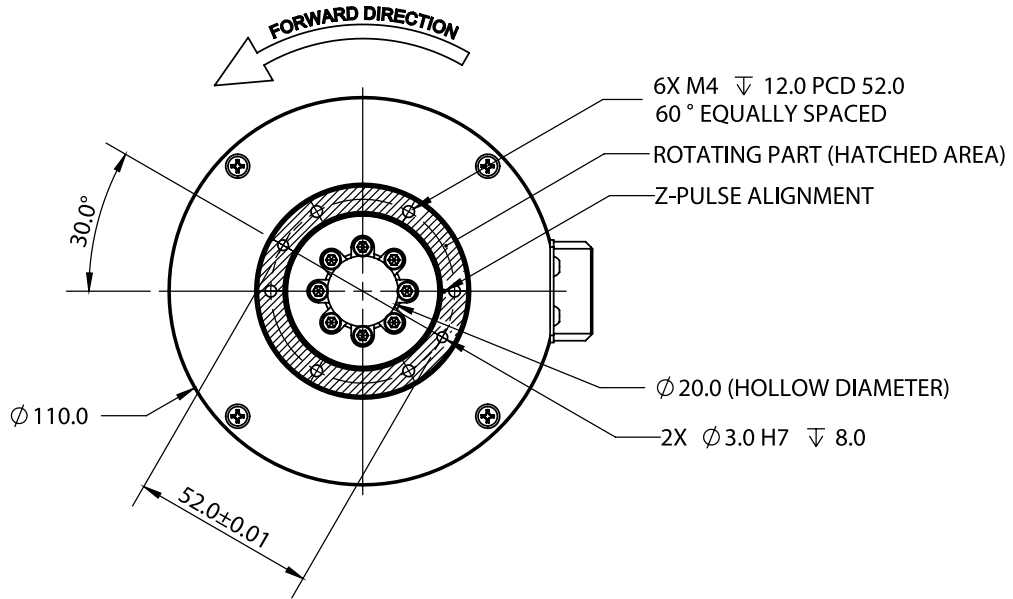

Model	PDDR110-6-I	PDDR110-12-I
L (mm)	85	116

PDDR SERIES

DIRECT DRIVE ROTARY MOTOR



PDDR150

- High RPM, speed and precision
- Peak torque up to 86 N.m

SPECIFICATION		MODEL				
		PDDR150-15-O	PDDR150-30-O	PDDR150-50-O	PDDR150-80-O	
Performance	Unit					
Peak Torque	N.m	15.7	32.2	54.4	86.6	
Continuous Torque @ 100°C*	N.m	5.2	10.7	18.1	28.9	
Peak Power @ 100°C	W	359.0	601.9	794.5	1155.6	
Continuous Power @ 100°C*	W	39.9	66.9	88.3	128.4	
Electrical						
Peak Current	Apk	7.6		15.7		
Continuous Current @ 100°C*	Apk	2.5		5.2		
Continuous Stall Current @ 100°C*	Arms	1.8		3.7		
Torque Constant	N.m/Apk	2.1		3.5	5.5	
Back EMF Constant	Vpk/rad/s	2.4		4.0	6.3	
Resistance L-L @ 25°C	Ohm	6.3	2.5	3.3	4.8	
Resistance L-L @ 100°C	Ohm	8.2	3.3	4.3	6.3	
Inductance L-L @ 1kHz	mH	31.8	15.9	26.8	39.7	
Motor Constant @ 100°C	N.m//W	0.8	1.3	1.9	2.5	
Max. Terminal Voltage	Vdc	400.0				
Thermal						
Thermal Resistance @ 100°C	°C/W	1.88	1.12	0.85	0.58	
Max. Winding Temperature	°C	120.0				
Mechanical						
Rotor Inertia	kg.m ²	0.012	0.021	0.024	0.029	
Motor Weight	kg	6.4	9.8	12.2	15.6	
Number of Pole Pairs	N-S	10.0				
Max. Speed*	RPS	5.0				
Max. Axial Load	kg	530.0				
Max. Moment Load	N.m	96.0				
Axial Run-out (no load)***	um	20/10/5				
Radial Run-out (no load)***	um	20/10/5				
Parallelism****	um	50/30/20				
Resolution (after quadrature)	CPR	A	B(x80)	C (x200)	D(x400)	E(x1000)
		8,192	655,360	1,638,400	3,276,800	8,192,000
Repeatability**	arcsec	+/-2				
Accuracy	arcsec	+/-30 / +/-15				

Notes:

1. Apk = 1.414 * Arms; Vpk = 1.414 * Vrms.
2. * Ambient temperature 25°C, heat dissipation by natural convection, without heat sink attached.
3. Specifications tolerance : ±10%.
4. ** Depend on encoder resolution.
5. *** Standard run-out 20um. Contact PBA for 10um and 5um.
6. **** Standard parallelism 50um. Contact PBA for 30um and 20um.
7. Peak force and current : 4% duty ratio and 1 second duration.
8. Specifications are subject to change without prior notice.

PDDR150

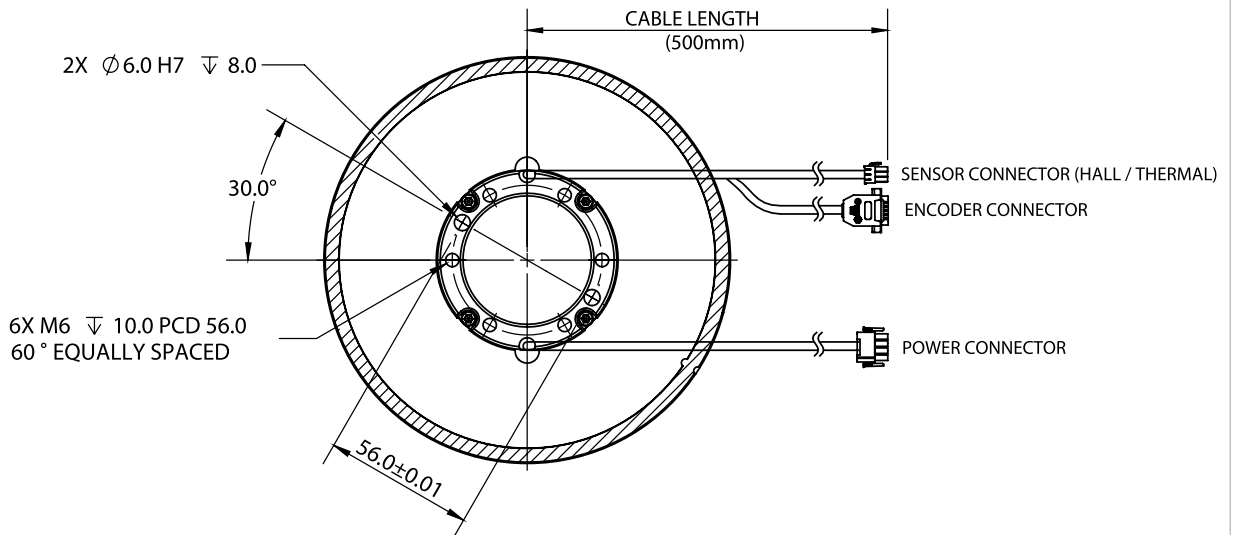
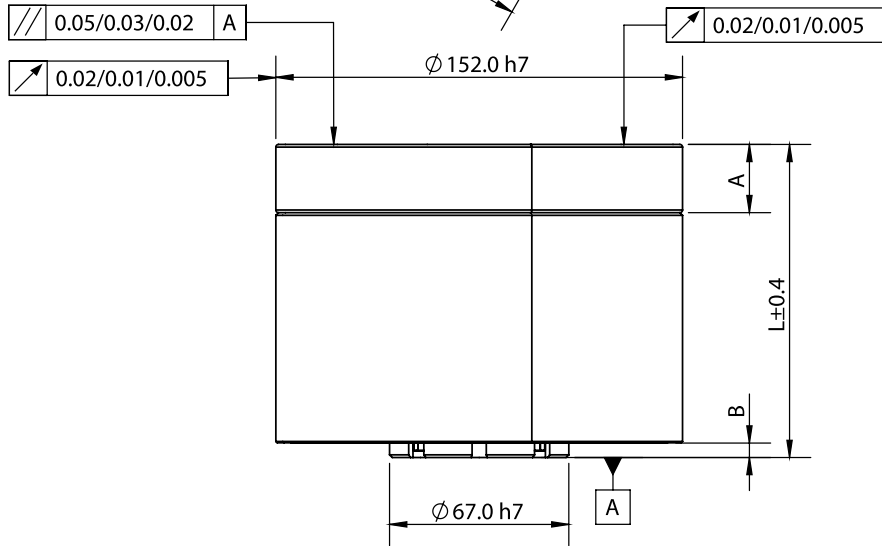
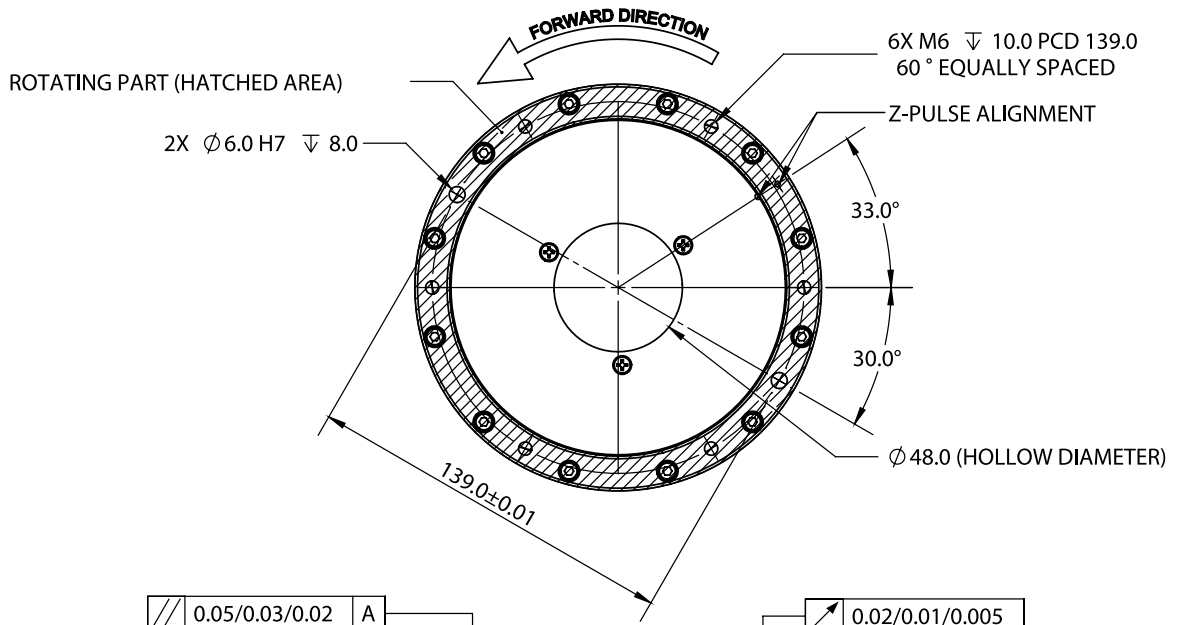

Model	PDDR150-15-O	PDDR150-30-O	PDDR150-50-O	PDDR150-80-O
L (mm)	85	117	139	171
A (mm)	35	36	36	36
B (mm)	2	5.5	5.5	5.5

PDDR SERIES

DIRECT DRIVE ROTARY MOTOR

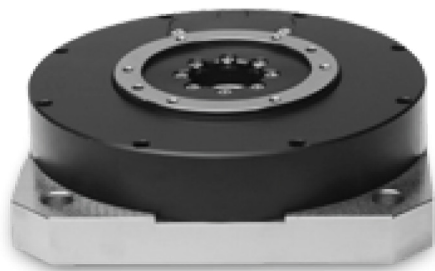

PDDR150-T

- High RPM, speed and precision
- Peak torque up to 4.3 N.m

SPECIFICATION		MODEL				
		PDDR150-T-I				
Performance	Unit					
Peak Torque	N.m	4.3				
Continuous Torque @ 100°C*	N.m	1.4				
Peak Power @ 100°C	W	263.4				
Continuous Power @ 100°C*	W	29.3				
Electrical						
Peak Current	Apk	5.1				
Continuous Current @ 100°C*	Apk	1.7				
Continuous Stall Current @ 100°C*	Arms	1.2				
Torque Constant	N.m/Apk	0.8				
Back EMF Constant	Vpk/rad/s	1.0				
Resistance L-L @ 25°C	Ohm	10.4				
Resistance L-L @ 100°C	Ohm	13.6				
Inductance L-L @ 1kHz	mH	8.3				
Motor Constant @ 100°C	N.m//W	0.3				
Max. Terminal Voltage	Vdc	400.0				
Thermal						
Thermal Resistance @ 100°C	°C/W	2.56				
Max. Winding Temperature	°C	120.0				
Mechanical						
Rotor Inertia	kg.m ²	0.00226				
Motor Weight	kg	4.4				
Number of Pole Pairs	N-S	8.0				
Max. Speed*	RPS	10.0				
Max. Axial Load	kg	120.0				
Max. Moment Load	N.m	15.0				
Axial Run-out (no load)***	um	20/10/5				
Radial Run-out (no load)***	um	20/10/5				
Parallelism****	um	40/20/10				
Resolution (after quadrature)	CPR	A	B(x80)	C (x200)	D(x400)	E(x1000)
		8,192	655,360	1,638,400	3,276,800	8,192,000
Repeatability**	arcsec	+/-2				
Accuracy	arcsec	+/-30 / +/-15				

Notes:

1. Apk = 1.414 * Arms; Vpk = 1.414 * Vrms.
2. * Ambient temperature 25°C, heat dissipation by natural convection, without heat sink attached.
3. Specifications tolerance : ±10%.
4. ** Depend on encoder resolution.
5. *** Standard run-out 20um. Contact PBA for 10um and 5um.
6. **** Standard parallelism 50um. Contact PBA for 30um and 20um.
7. Peak force and current : 4% duty ratio and 1 second duration.
8. Specifications are subject to change without prior notice.

PDDR150-T

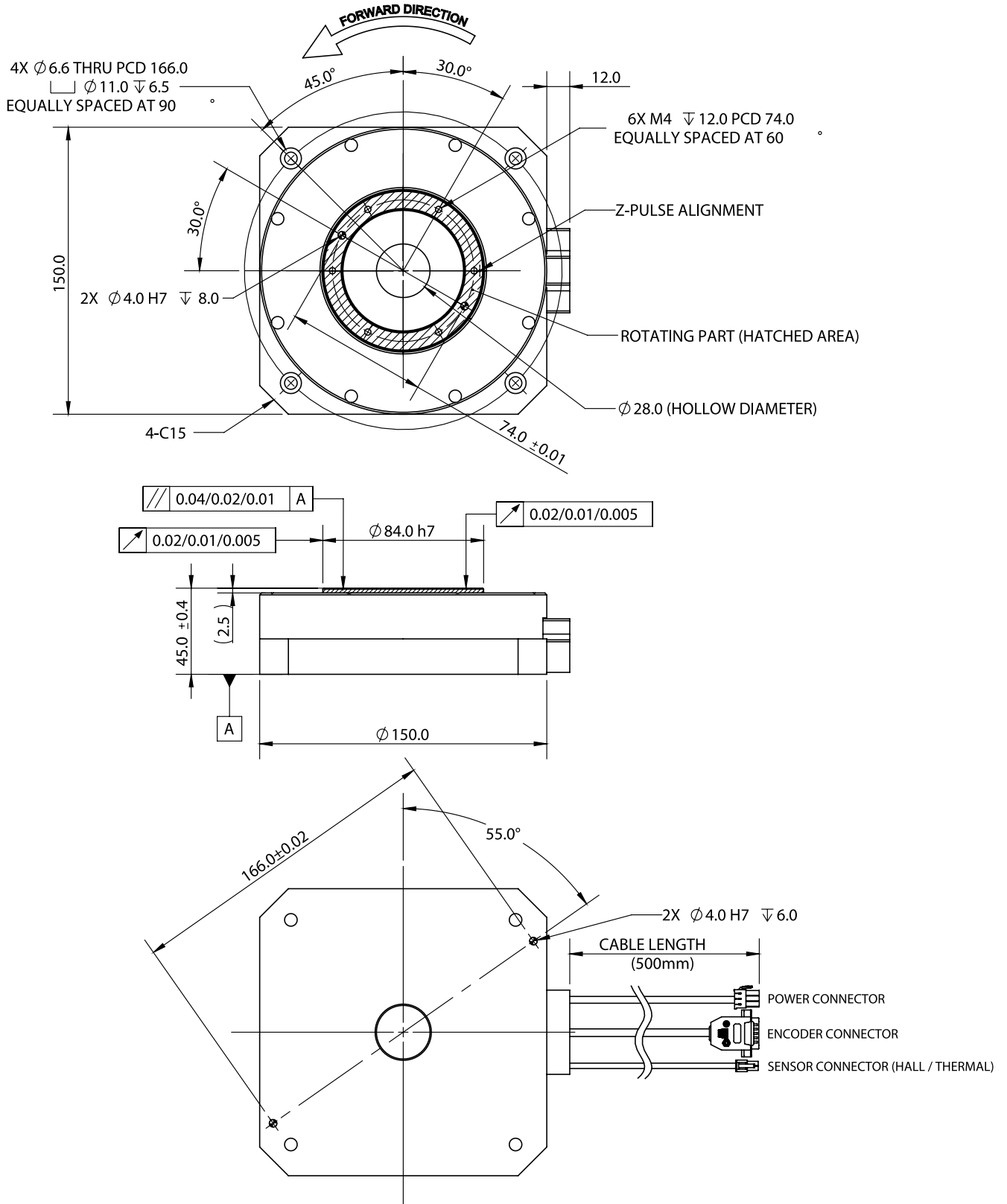

- DXB/BT
- PIX
- PSM/PSME
- CVC
- CVCA
- RVCA
- PDDR**
- PCA
- PVA
- PLA
- PDAB
- PIAB
- OCTO
- PRG
- LINEAR ENCODER
- SERVO AMPLIFIER

PDDR SERIES

DIRECT DRIVE ROTARY MOTOR



PDDR160

- High RPM, speed and precision
- Peak torque up to 81 N.m

SPECIFICATION		MODEL				
		PDDR160-40-I		PDDR160-80-I		
Performance	Unit					
Peak Torque	N.m	40.0		81.0		
Continuous Torque @ 100°C*	N.m	13.3		27.0		
Peak Power @ 100°C	W	975.5		1851.8		
Continuous Power @ 100°C*	W	108.4		205.8		
Electrical						
Peak Current	Apk	18.2		38.2		
Continuous Current @ 100°C*	Apk	6.1		12.7		
Continuous Stall Current @ 100°C*	Arms	4.3		9.0		
Torque Constant	N.m/Apk	2.2		2.1		
Back EMF Constant	Vpk/rad/s	2.5		2.4		
Resistance L-L @ 25°C	Ohm	3.0		1.3		
Resistance L-L @ 100°C	Ohm	3.9		1.7		
Inductance L-L @ 1kHz	mH	10.4		4.6		
Motor Constant @ 100°C	N.m//W	1.3		1.9		
Max. Terminal Voltage	Vdc	400.0				
Thermal						
Thermal Resistance @ 100°C	°C/W	0.69		0.36		
Max. Winding Temperature	°C	120.0				
Mechanical						
Rotor Inertia	kg.m ²	0.0031		0.0052		
Motor Weight	kg	13.9		22.0		
Number of Pole Pairs	N-S	10.0				
Max. Speed*	RPS	8.0		9.0		
Max. Axial Load	kg	120.0				
Max. Moment Load	N.m	15.0				
Axial Run-out (no load)***	um	20/10/5				
Radial Run-out (no load)***	um	20/10/5				
Parallelism****	um	50/30/20				
Resolution (after quadrature)	CPR	A	B(x80)	C (x200)	D(x400)	E(x1000)
		4,096	327,680	819,200	1,638,400	4,096,000
Repeatability**	arcsec	+/-4				
Accuracy	arcsec	+/-30 ,+/-15				

- Notes:
1. Apk = 1.414 * Arms; Vpk = 1.414 * Vrms.
 2. * Ambient temperature 25°C, heat dissipation by natural convection, without heat sink attached.
 3. Specifications tolerance : ±10%.
 4. ** Depend on encoder resolution.
 5. *** Standard run-out 20um. Contact PBA for 10um and 5um.
 6. **** Standard parallelism 50um. Contact PBA for 30um and 20um.
 7. Peak force and current : 4% duty ratio and 1 second duration.
 8. Specifications are subject to change without prior notice.

PDDR160

DXB/BT
 PIX
 PSM/PSME
 CVC
 CVCA
 RVCA
PDDR
 PCA
 PVA
 PLA
 PDAB
 P/AB
 OCTO
 PRG
 LINEAR ENCODER
 SERVO AMPLIFIER

BOTTOM TYPE

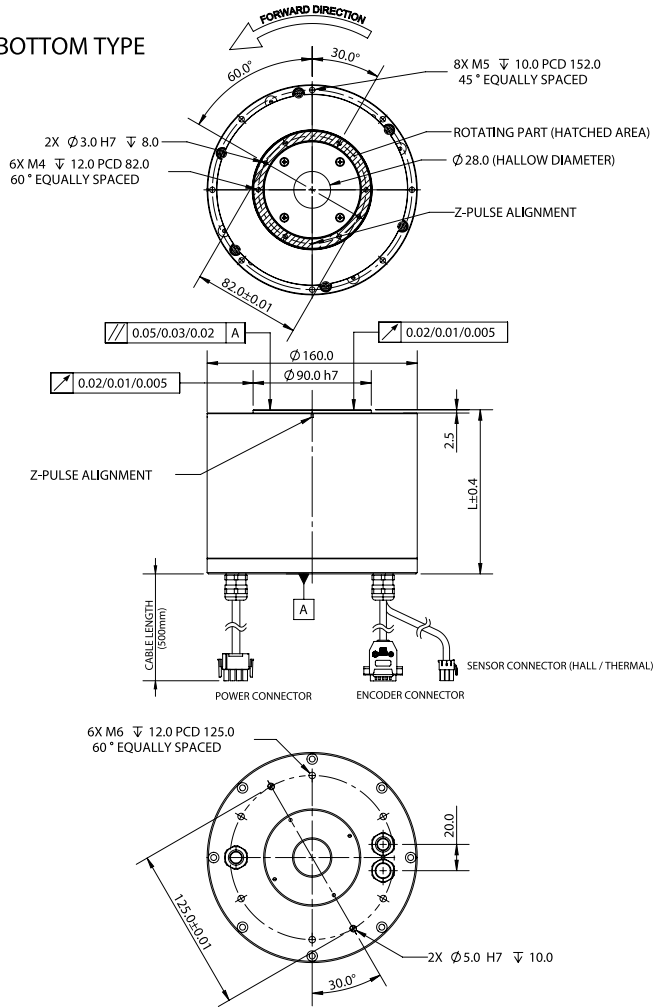

SIDE TYPE

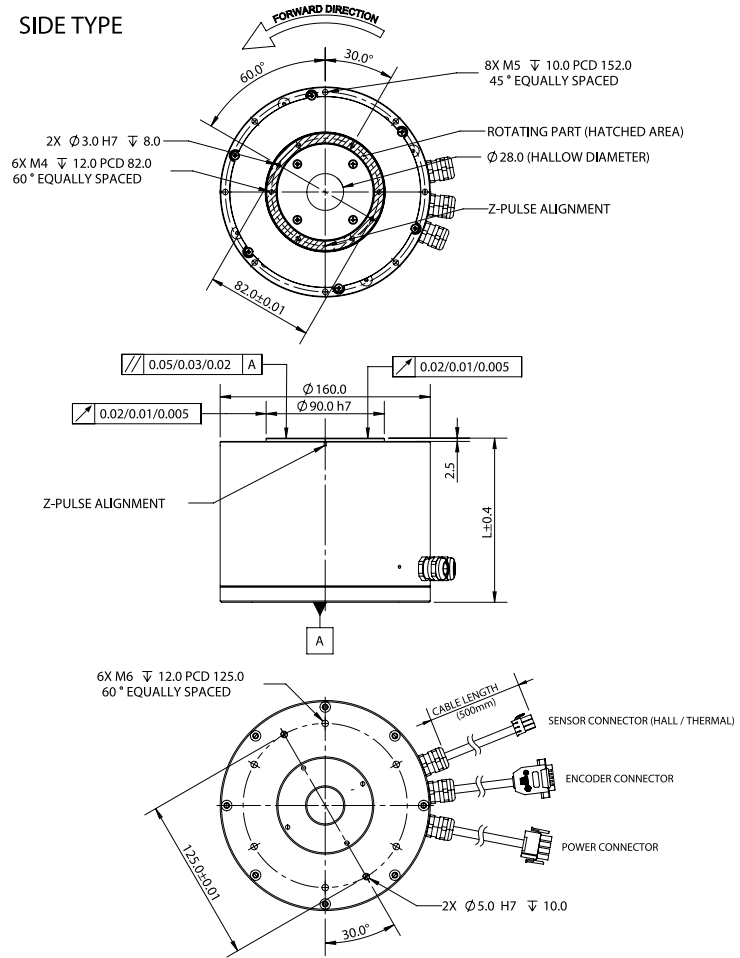

Model	PDDR160-40-I	PDDR160-80-I
L (mm)	125	187

PDDR SERIES

DIRECT DRIVE ROTARY MOTOR

PDDR240

- High RPM, speed and precision
- Peak torque up to 132 N.m

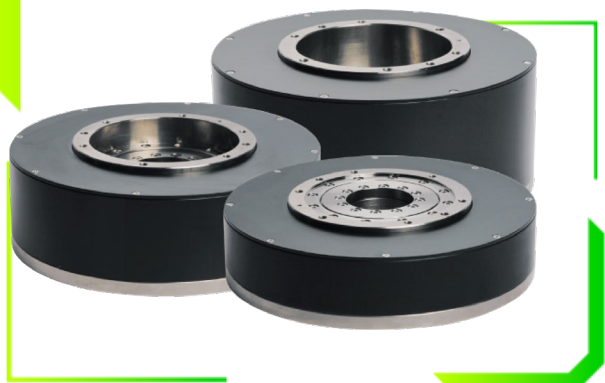

SPECIFICATION		MODEL				
		PDDR240-30-I		PDDR240-80-I		PDDR240-132-I
Performance	Unit					
Peak Torque	N.m	29.5	75.5	122.9		
Continuous Torque @ 100°C*	N.m	9.8	25.2	41.0		
Peak Power @ 100°C	W	557.1	955.5	1224.6		
Continuous Power @ 100°C*	W	61.9	106.2	136.1		
Electrical						
Peak Current	Apk	10.2	14.4	13.6		
Continuous Current @ 100°C*	Apk	3.4	4.8	4.5		
Continuous Stall Current @ 100°C*	Arms	2.4	3.4	3.2		
Torque Constant	N.m/Apk	2.9	5.2	9.1		
Back EMF Constant	Vpk/rad/s	3.3	6.0	10.4		
Resistance L-L @ 25°C	Ohm	5.5	4.7	6.8		
Resistance L-L @ 100°C	Ohm	7.2	6.1	8.9		
Inductance L-L @ 1kHz	mH	35.1	46.4	79.4		
Motor Constant @ 100°C	N.m//W	1.3	2.4	3.5		
Max. Terminal Voltage	Vdc	400.0				
Thermal						
Thermal Resistance @ 100°C	°C/W	1.21	0.71	0.55		
Max. Winding Temperature	°C	120.0				
Mechanical						
Rotor Inertia	kg.m ²	0.0092	0.0143	0.0203		
Motor Weight	kg	10.7	14.7	19.7		
Number of Pole Pairs	N-S	16.0				
Max. Speed*	RPS	5.0	4.5	2.8		
Max. Axial Load	kg	410.0				
Max. Moment Load	N.m	80.0				
Axial Run-out (no load)***	um	20/10/5				
Radial Run-out (no load)***	um	20/10/5				
Parallelism****	um	50/30/20				
Resolution (after quadrature)	CPR	A	B (x80)	C (x200)	D (x400)	E (x1000)
		8,192	655,360	1,638,400	3,276,800	8,192,000
Repeatability**	arcsec	+/-2				
Accuracy	arcsec	+/-30 / +/-15				

Notes:

1. Apk = 1.414 * Arms; Vpk = 1.414 * Vrms.
2. * Ambient temperature 25°C, heat dissipation by natural convection, without heat sink attached.
3. Specifications tolerance : ±10%.
4. ** Depend on encoder resolution.
5. *** Standard run-out 20um. Contact PBA for 10um and 5um.
6. **** Standard parallelism 50um. Contact PBA for 30um and 20um.
7. Peak force and current : 4% duty ratio and 1 second duration.
8. Specifications are subject to change without prior notice.

DXB/BT
 PIX
 PSM/PSME
 CVC
 CVCA
 RVCA
PDDR
 PCA
 PVA
 PLA
 PDAB
 PIAB
 OCTO
 PRG
 LINEAR ENCODER
 SERVO AMPLIFIER

PDDR240

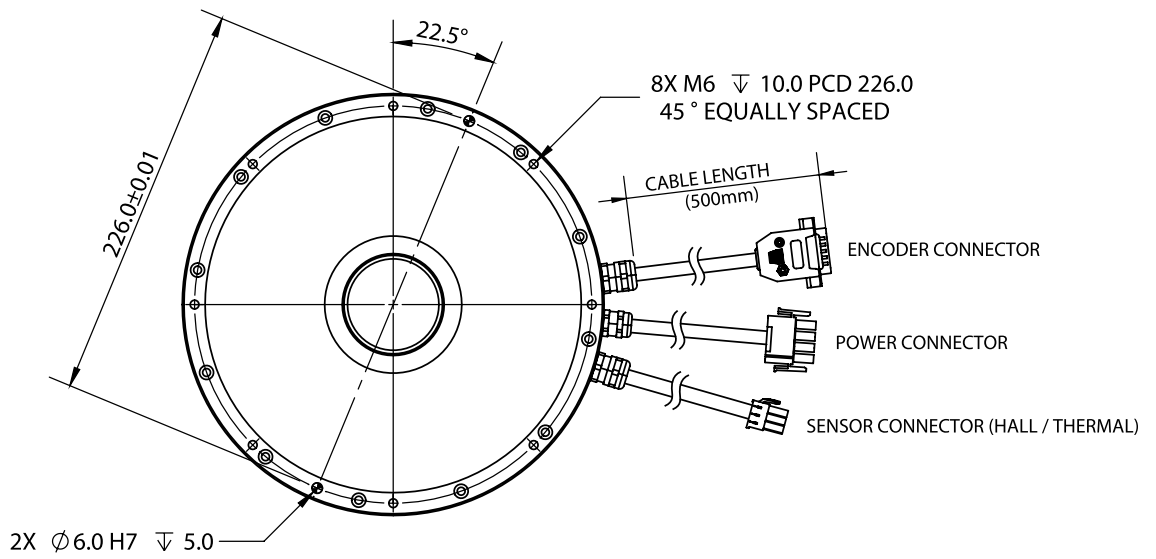
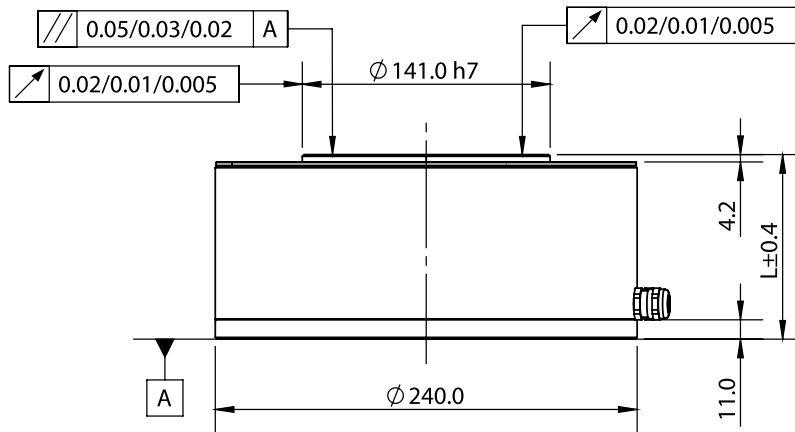
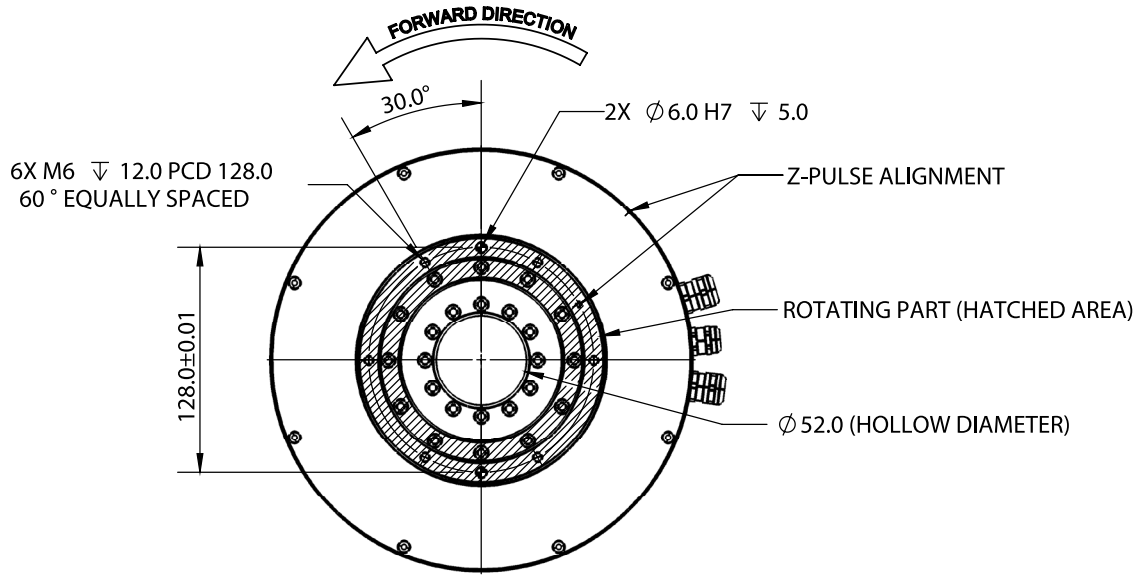

Model	PDDR240-30-I	PDDR240-80-I	PDDR240-132-I
L (mm)	59	80	105

PDDR SERIES

DIRECT DRIVE ROTARY MOTOR

PDDR300

- High RPM, speed and precision
- Peak torque up to 450 N.m



SPECIFICATION		MODEL				
		PDDR300-150-I		PDDR300-300-I		PDDR300-450-I
Performance	Unit					
Peak Torque	N.m	149.5	299.7	450.9		
Continuous Torque @ 100°C*	N.m	49.8	99.9	150.3		
Peak Power @ 100°C	W	1592.8	3133.9	4131.0		
Continuous Power @ 100°C*	W	177.0	348.2	459.0		
Electrical						
Peak Current	Apk	19.9	38.2			
Continuous Current @ 100°C*	Apk	6.6	12.7			
Continuous Stall Current @ 100°C*	Arms	4.7	9.0			
Torque Constant	N.m/Apk	7.5	7.9	11.8		
Back EMF Constant	Vpk/rad/s	8.6	9.0	13.6		
Resistance L-L @ 25°C	Ohm	4.1	1.6	2.2		
Resistance L-L @ 100°C	Ohm	5.3	2.1	2.9		
Inductance L-L @ 1kHz	mH	47.7	23.8	36.2		
Motor Constant @ 100°C	N.m/√W	3.7	6.3	8.1		
Max. Terminal Voltage	Vdc	400.0				
Thermal						
Thermal Resistance @ 100°C	°C/W	0.42	0.30	0.22		
Max. Winding Temperature	°C	120.0				
Mechanical						
Rotor Inertia	kg.m ²	0.1004	0.1288	0.1576		
Motor Weight	kg	46.7	58.5	70.2		
Number of Pole Pairs	N-S	16.0				
Max. Speed*	RPS	2.9	3.0	2.0		
Max. Axial Load	kg	1100.0				
Max. Moment Load	N.m	250.0				
Axial Run-out (no load)***	um	30/15/5				
Radial Run-out (no load)***	um	30/15/5				
Parallelism****	um	50/30/20				
Resolution (after quadrature)	CPR	A	B (x80)	C (x200)	D (x400)	E (x1000)
		10,800	864,000	2,160,000	4,320,000	10,800,000
Repeatability**	arcsec	+/-2				
Accuracy	arcsec	+/-30 / +/-15				

Notes:

1. Apk = 1.414 * Arms; Vpk = 1.414 * Vrms.
2. * Ambient temperature 25°C, heat dissipation by natural convection, without heat sink attached.
3. Specifications tolerance : ±10%.
4. ** Depend on encoder resolution.
5. *** Standard run-out 20um. Contact PBA for 10um and 5um.
6. **** Standard parallelism 50um. Contact PBA for 30um and 20um.
7. Peak force and current : 4% duty ratio and 1 second duration.
8. Specifications are subject to change without prior notice.

PDDR300

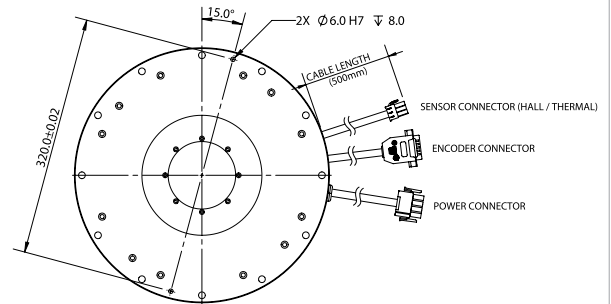
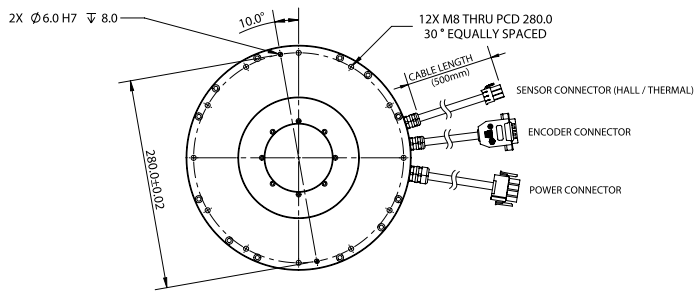
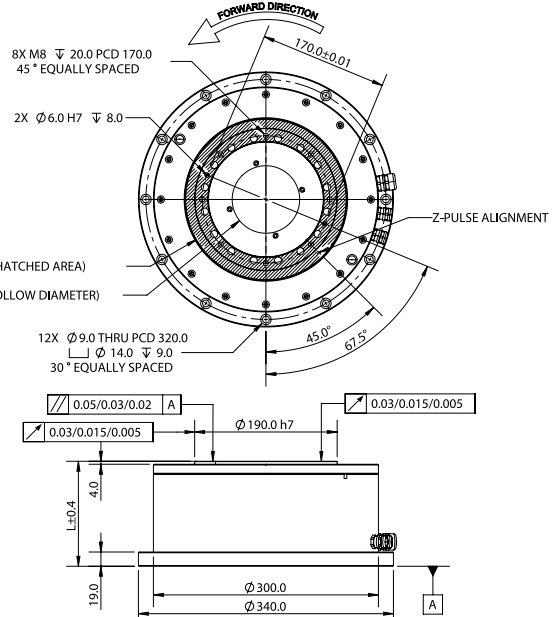
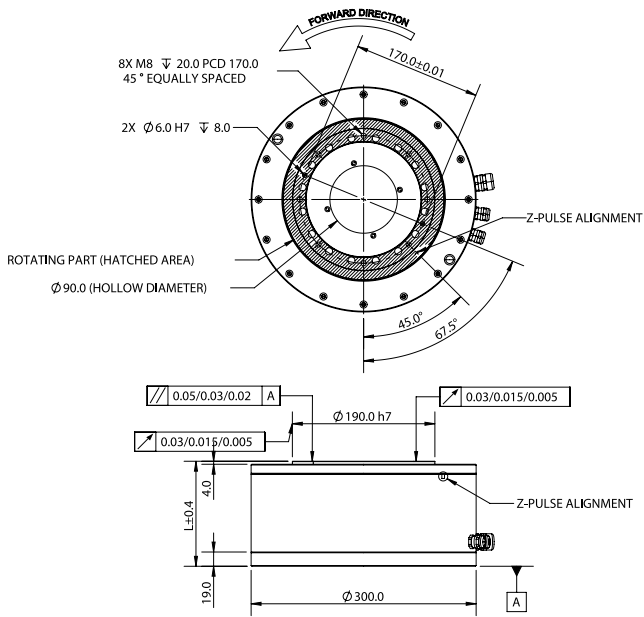

Model	PDDR300-150-I	PDDR300-300-I	PDDR300-450-I
L (mm)	140	173	207

PDDR SERIES

DIRECT DRIVE ROTARY MOTOR

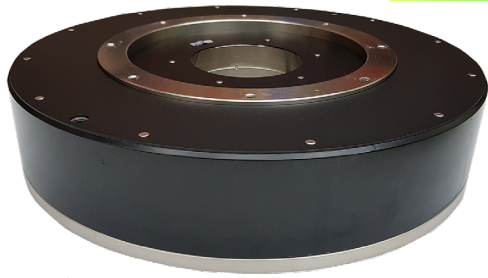

PDDR490

- High RPM, speed and precision
- Peak torque up to 1090 N.m

SPECIFICATION		MODEL				
		PDDR490-600-I		PDDR490-900-I		PDDR490-1200-I
Performance	Unit					
Peak Torque	N.m	540.0	780.0	1090.0		
Continuous Torque @ 100°C*	N.m	200.0	300.0	400.0		
Peak Power @ 100°C	W	3845.2	4806.5	5767.8		
Continuous Power @ 100°C*	W	344.7	430.9	517.0		
Electrical						
Peak Current	Apk	49.6				
Continuous Current @ 100°C*	Apk	14.8				
Continuous Stall Current @ 100°C*	Arms	10.5				
Torque Constant	N.m/Apk	13.4	20.2	26.9		
Back EMF Constant	Vpk/rad/s	15.5	23.3	31.0		
Resistance L-L @ 25°C	Ohm	1.6	2.0	2.4		
Resistance L-L @ 100°C	Ohm	2.1	2.6	3.1		
Inductance L-L @ 1kHz	mH	20.0	29.7	41.1		
Motor Constant @ 100°C	N.m/√W	10.7	14.5	17.6		
Max. Terminal Voltage	Vdc	400.0				
Thermal						
Thermal Resistance @ 100°C	°C/W	0.22	0.17	0.15		
Max. Winding Temperature	°C	120.0				
Mechanical						
Rotor Inertia	kg.m ²	0.536	0.631	0.762		
Motor Weight	kg	80.2	91.5	100.5		
Number of Pole Pairs	N-S	24.0				
Max. Speed*	RPS	2.3	1.4	1.0		
Max. Axial Load	kg	1100.0				
Max. Moment Load	N.m	250.0				
Axial Run-out (no load)***	um	40/20/5				
Radial Run-out (no load)***	um	40/20/5				
Parallelism****	um	100				
Resolution (after quadrature)	CPR	A	B (x80)	C (x200)	D (x400)	E (x1000)
		12,960	1,036,800	2,592,000	5,184,000	12,960,000
Repeatability**	arcsec	+/-2				
Accuracy	arcsec	+/-30 / +/-15				

- Notes:
1. Apk = 1.414 * Arms; Vpk = 1.414 * Vrms.
 2. * Ambient temperature 25°C, heat dissipation by natural convection, without heat sink attached.
 3. Specifications tolerance : ±10%.
 4. ** Depend on encoder resolution.
 5. *** Standard run-out 20um. Contact PBA for 10um and 5um.
 6. **** Standard parallelism 50um. Contact PBA for 30um and 20um.
 7. Peak force and current : 4% duty ratio and 1 second duration.
 8. Specifications are subject to change without prior notice.

DXB/BT
 PIX
 PSM/PSME
 CVC
 CVCA
 RVCA
PDDR
 PCA
 PVA
 PLA
 PDAB
 PIAB
 OCTO
 PRG
 LINEAR ENCODER
 SERVO AMPLIFIER

PDDR490

DXB/BT
 PIX
 PSM/PSME
 CVC
 CVCA
 RVCA
PDDR
 PCA
 PWA
 PLA
 PDAB
 PIAB
 OCTO
 PRG
 LINEAR ENCODER / SERVO AMPLIFIER

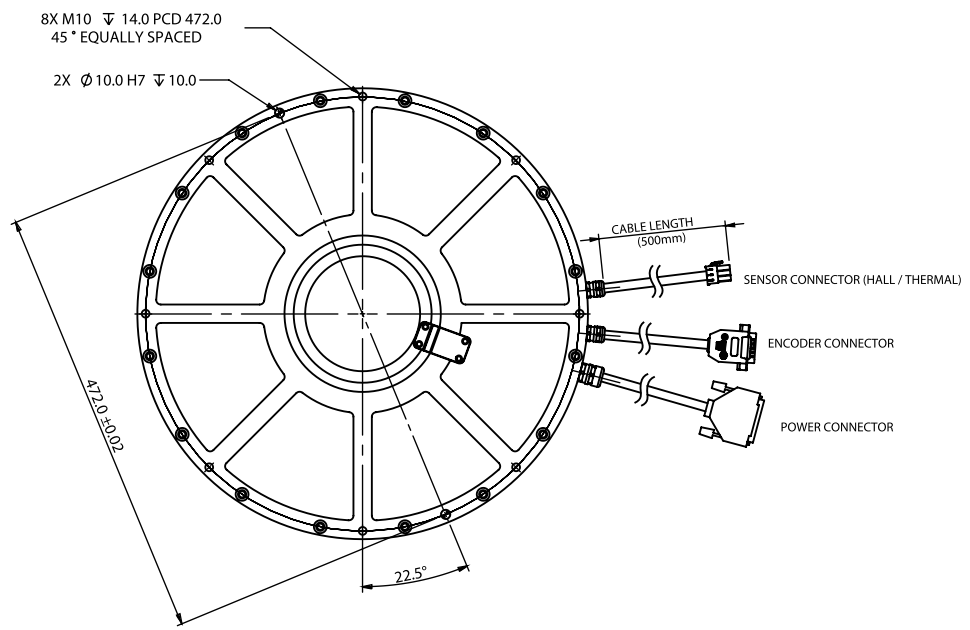
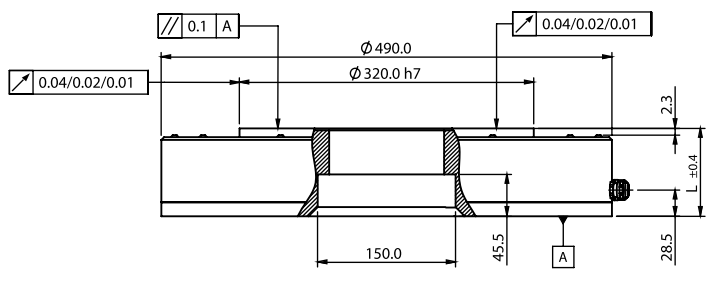
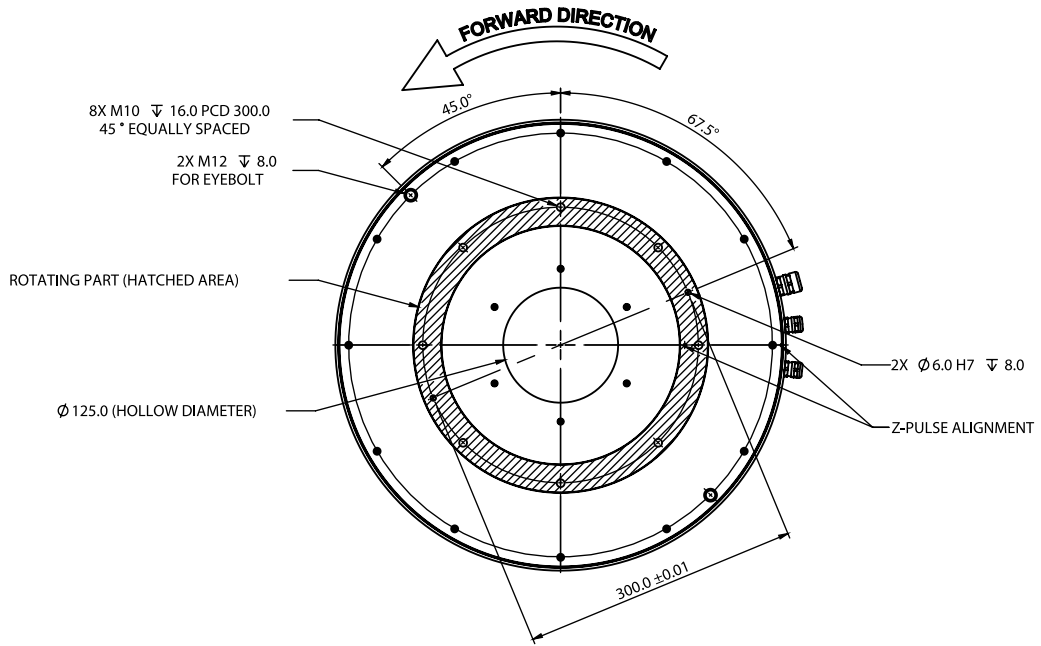

Model	PDDR490-600-I	PDDR490-900-I	PDDR490-1200-I
A	95.5	107.5	126.5

CABLE OPTION

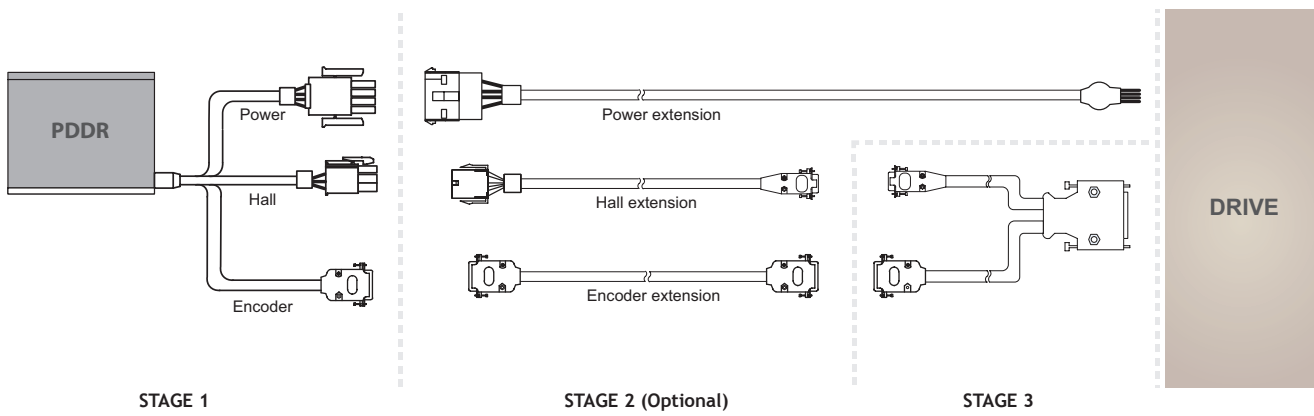

STAGE 1 | PDDR SERIES CABLE COLOUR CODE AND PIN OUT

MOTOR PHASE PIN OUT

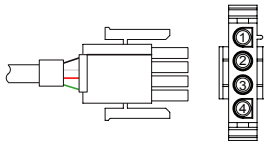

1	U	Black
2	V	White
3	W	Red
4	PE	Green

(PDDR150 / PDDR160 / PDDR240 / PDDR300)

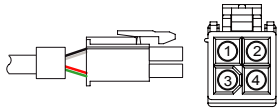

1	U	Black
2	V	White
3	W	Red
4	PE	Green

(PDDR110 / PDDR150-T)

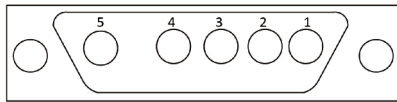

Motor Phase:

1	U	Black
2	V	White
3	W	Red
4	PE	Green

(PDDR490)

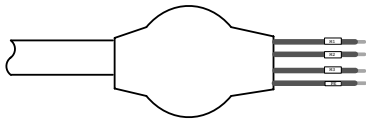

M1	Grey
M2	Brown
M3	Black
PE	Yellow

Ferrite core type

HALL SENSOR PIN OUT

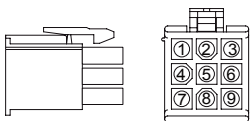

1	VCC	Red
2	GND	Black
3	HA	Blue
4	HB	Yellow
5	HC	Green
6	Thermal sensor	White
7	N.C.	-
8	N.C.	-
9	Shield	Shield

ENCODER CONNECTOR PIN OUT

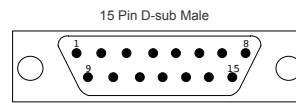

Digital Standard Resolution

1	N.C.
2	GND
3	N.C.
4	Z-
5	B-
6	A-
7	5V
8	N.C.
9	N.C.
10	N.C.
11	N.C.
12	Z+
13	B+
14	A+
15	N.C.
Case	Shield

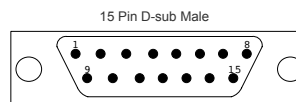

Analog

1	COSINE-
2	SINE-
3	Index+
4	5V
5	N.C.
6	N.C.
7	N.C.
8	N.C.
9	COSINE+
10	SINE+
11	Index-
12	GND
13	N.C.
14	N.C.
15	N.C.
Case	Shield

Notes: All connectors shown are front view

STAGE 2 | PDDR SERIES EXTENSION CABLE

Connection example: PDDR160-□-□-□

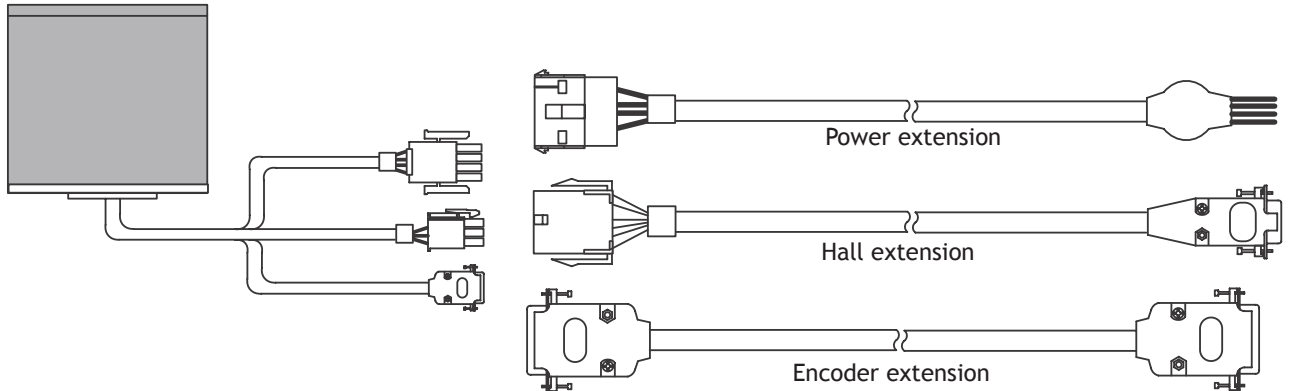

PDDR SERIES EXTENSION CABLE

	Extension Cable	Part Number
Power Extension Cable		CBL_EXT_PWR1_PDDR_X.X (PDDR150 / PDDR160 / PDDR240 / PDDR300)
		CBL_EXT_PWR2_PDDR_X.X (PDDR110 / PDDR150-T)
		CBL_EXT_PWR3_PDDR_X.X (PDDR490 only)
Hall Sensor Extension Cable		CBL_EXT_HALL1_X.X
Encoder Extension Cable	 Standard encoder	CBL_EXT_SENC_PDDR_X.X
	 Analog encoder	CBL_EXT_AENC_PDDR_X.X

Notes: 1. X.X is the length of the cable in meters 2. For customized cable length, contact PBA

Application Form - DDR Motor Selection

Customer Name:	Date (DD/MM/YY):
Contact Email:	

PBA DDR MOTOR SELECTION QUESTIONNAIRE

1. Application Description

1a. Application Sketch With Approx Dimensions

2. Load Parameter (Please Circle Accordingly)

a) Load moment of inertia		kg.m ²	
Frictional torque		N.m	
Table	b) Table top shape	Disk / Rectangular Plate	
	Material	Steel / Aluminium	
	Dimension	Dt (mm)	
	Plate thickness	ht (mm)	
	Weight	m1 (kg)	
Workpiece	c) Quantity	nw (pc.)	
	Max. weight	mw (kg/pc.)	
	Installation center	Dp (mm)	
Pallet Jig	d) Quantity	np (pc.)	
	Max. weight	mp (kg/pc.)	

Mounting Requirements

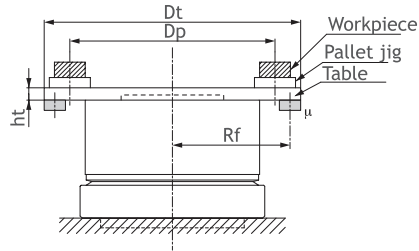
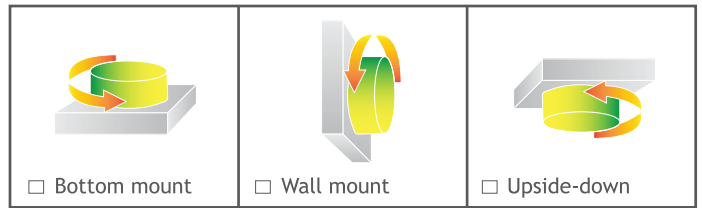

3. Motion Parameter

		Profile 1	Profile 2	Profile 3
Rotational angle (θ)	°			
Moving time	s			
Moving speed	rps			
Dwell time	s			

4. Command/Bus (Please Circle Accordingly)

Pulse and direction / Analog / EtherCAT / IO trigger / Other : _____

5. Encoder (Please Circle Accordingly)

Incremental / Analog		
Resolution	cpr	327680 / 518400 / 655360 / 864000

6. Motion Precision

Accuracy	arcsec	
Repeatability	arcsec	

7. Mechanical Specification (Please Circle Accordingly)

Axial run-out	um	5 / 10 / 20
Radial run-out	um	5 / 10 / 20
Space constraints (H x W)	mm	

8. Working Environment

Room temperature	°C	
Clean room class		

9. Additional Requirements (Please Tick () Accordingly)

Motor extension cable length	Flexible cable	Amplifier	Controller	Other: _____
m				

10. Remarks: If you have any special motion request for sizing procedure, please specify your requirement in below remarks.

Formula of moment of inertia

(m : Weight of object (kg))

● A When rotation center is own shaft

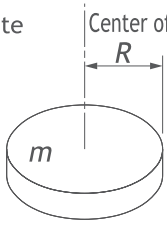
1. Circular plate (cylinder)
 

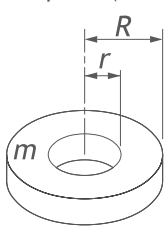
$$I = \frac{mR^2}{2}$$
2. Hollow circular plate (hollow cylinder)
 

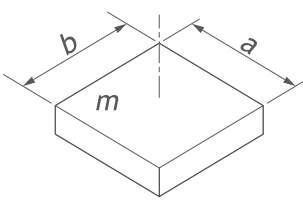
$$I = \frac{m(R^2 + r^2)}{2}$$
3. Direct hexagonal side finish body
 

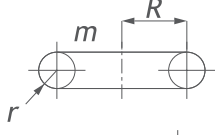
$$I = \frac{m(a^2 + b^2)}{12}$$
4. Ring
 

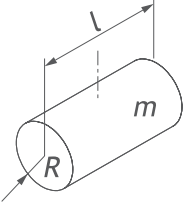
$$I = \frac{m(4R^2 + 3r^2)}{4}$$
5. Cylinder
 

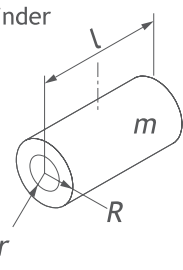
$$I = \frac{m(3R^2 + l^2)}{12}$$
6. Hollow cylinder
 

$$I = \frac{m(R^2 + r^2 + l^2/3)}{4}$$

● B When rotation center differs from own shaft

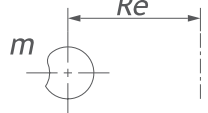
1. Any shape (if small very well)
 

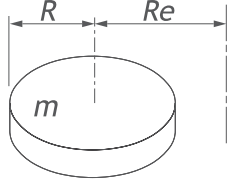
$$I = mRe^2$$
2. Circular plate (cylinder)
 

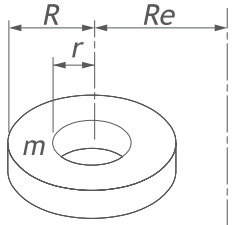
$$I = m\left(\frac{R^2}{2} + Re^2\right)$$
3. Hollow circular plate (hollow cylinder)
 

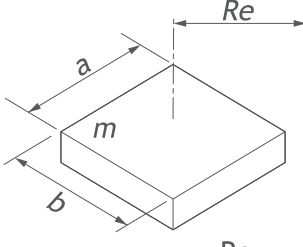
$$I = m\left(\frac{R^2 + r^2}{2} + Re^2\right)$$
4. Direct hexagonal side finish body
 

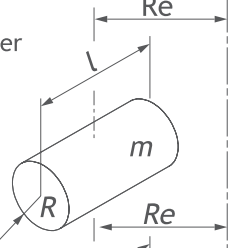
$$I = m\left(\frac{a^2 + b^2}{12} + Re^2\right)$$
5. Cylinder
 

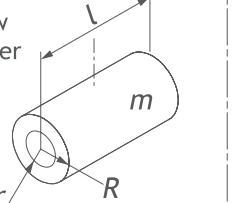
$$I = m\left(\frac{3R^2 + l^2}{12} + Re^2\right)$$
6. Hollow cylinder
 

$$I = m\left(\frac{R^2 + r^2 + l^2/3}{4} + Re^2\right)$$

● For conveyer

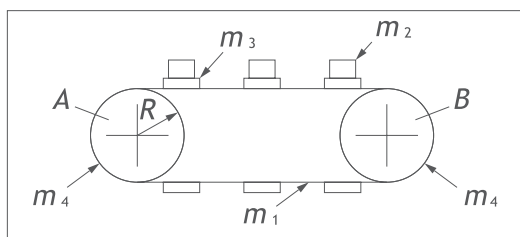

m_1 : Chain weight
 m_2 : Workpiece total weight
 m_3 : Jig (pallet) total weight
 m_4 : Sprocket A (drive) + B total weight
 R : Drive side sprocket radius

$$I = (m_1 + m_2 + m_3 + \frac{m_4}{2}) \cdot R^2$$

PBA SYSTEMS LINEAR MOTOR SIZER SOFTWARE



PBA Systems is a one-stop robotics provider with a focus on the development of core technology to offer a robust range of products and solutions in precision robotics and general robotics - enabling companies to thrive by making Industry 4.0 technology accessible to the market.

Our core strength is in design, development, and manufacturing of direct drive motor design and manufacturing, motion control, and precision modular assemblies.

Address:
**505 Yishun Industrial Park, A,
 Singapore 768733**

Contact Us:
**Tel: +(65) 6576 6766
 Fax: +(65) 6576 6768**



PBA SYSTEMS LINEAR MOTOR SIZER SOFTWARE

PBA Systems Motor Sizer Software is available to download from our website to assist in the calculation and selection.

Kindly visit us at www.pbasystems.com.sg or simply scan the QR CODE

SIMULATED PERFORMANCE CHARTS

PBA Motor Sizer

Application Version: 10.7.0.0 | Local Database Version: 7.0.16 | Server Database Version: 7.0.16

Guest About PBA Online

Motor Sizer

Project Details
 Customer Name: PBA | Project Name: XYZ | Date: 6/1/2022 | Project Data Version: 7.0.16

Axis Details
 Axis Name: X | Motor Category: DXB | Safety Margin: 20 (slider) | 300

Profiles

No	Motion Profile	Travel Distance (m)	Travel Time (s)	Max. Speed (m/s)	Max. Accel. (m/s ²)	Dwell Time (s)	Mass of Load (Kg)	Angle Of Incl. (°)	Direction	Coefficient of Friction	Opposing Force (N)	Ambient Temp. (°C)	RMS Force (N)	Peak Force (N)	Frictional Force (N)	Accel. Time (s)	Cruise Time (s)	Decel. Time (s)	Total Time (s)
1	Trapezoidal	1.000	1.000	1.500	4.500	0.100	10.000	0.000	▶	0.003	0.000	30.000	35.034	45.294	0.294	0.333	0.333	0.333	1.100
2	Trapezoidal	0.500	1.000	0.750	2.250	0.000	20.000	0.000	▶	0.003	0.000	30.000	36.747	45.589	0.589	0.333	0.333	0.333	1.000
3	Trapezoidal	0.500	1.000	0.750	2.250	0.000	30.000	0.000	▶	0.003	0.000	30.000	55.121	68.383	0.883	0.333	0.333	0.333	1.000

Final Calculations for Axis

Required RMS Force	43.026 N	Recommended Motor	Safety (%)
Required Peak Force	68.383 N	DX30B-C2-S	32
Total Travel Distance	2.000 m	DX30B-C2-P	32
Total Cycle Time	3.100 s	DX50B-C2-S	101
Total Dwell Time	0.100 s	DX50B-C2-P	101
Max Speed	1.500 m/s	DX50BT-C2-P	101
Max Acceleration	4.500 m/s ²	DX50BT-C4-P	294
Max. Ambient Temp.	30.000 °C		

Selected Motor
 Motor: DX50B-C2-S

Continuous Force	89.00 N	L To L Resistance	8.40 ohm
Peak Force	446.00 N	L To L Inductance	6.22 mH
Continuous Current	2.63 A	Continuous Power	60.00 W
Peak Current	13.13 A	Peak Power	1502.00 W
Motor Constant	11.51 N/vW	Coil Weight	0.520 kg
Force Constant	34.00 N/A	Coil Length	121.00 mm
Back EMF Constant	39.10 V/(m/s)	Attractive Force	0.00 N

Calculated Motor Values for Application

Reqd. RMS Force	44.21 N	Reqd. Peak Force	69.57 N
Cont. Current	1.30 A	Peak Current	2.05 A
Coil Temp	48.03 °C	DC Bus Voltage	70.42 V
Safety Factor	101.29 %		

Servo Drive Model: MT-6/25-230AP1

Cont. Current	6.30 A	Peak Current	25.40 A
---------------	--------	--------------	---------

APPENDIX

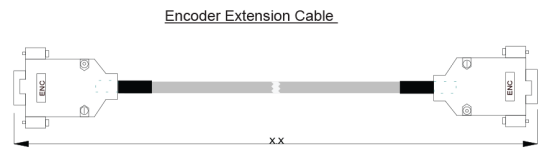
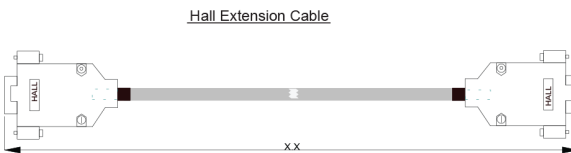
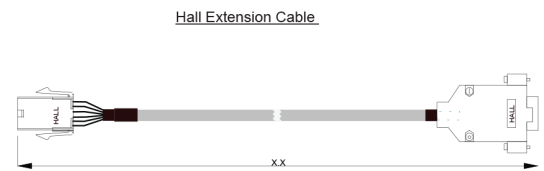
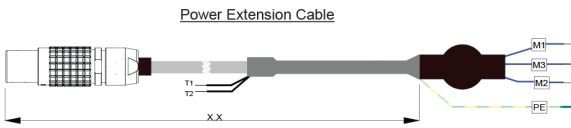
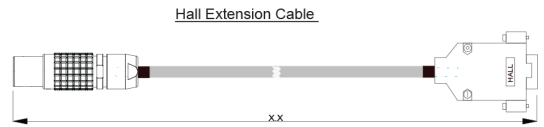
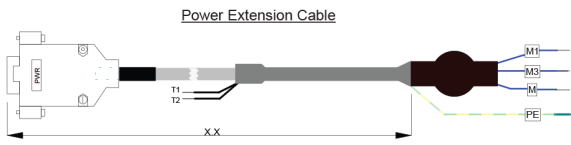

MOTOR POWER HALL CABLE

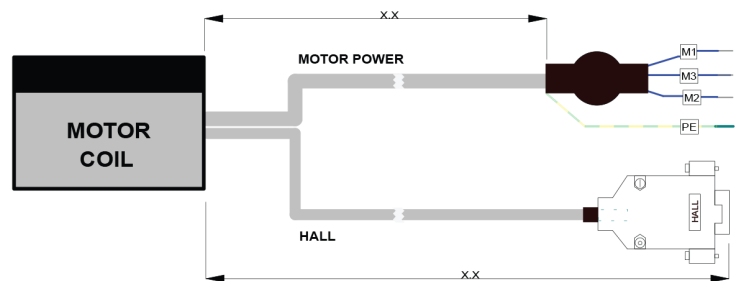

MAXTUNE FEEDBACK CABLE

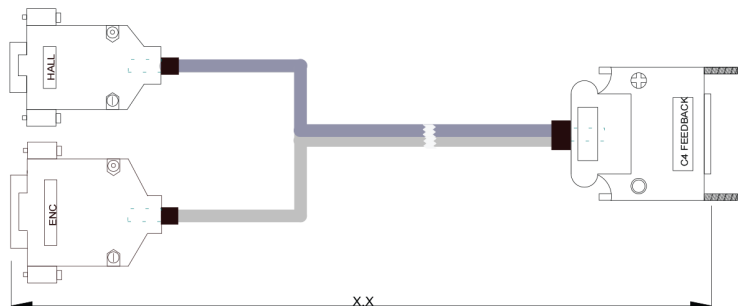

Notes:

1. X.X is the length of the cable in meter with a tolerance of $+0.10$
 -0
2. All measurements are in meters (m) unless stated