

Cartridge Direct Drive Rotary™ Motors Selection Guide



with AKD® Servo Drive Systems

KOLLMORGEN®

Because Motion Matters™

Kollmorgen: Your partner. In Motion.

Every solution comes from a real understanding of the challenges facing machine designers and users.

Innovators consistently rate Kollmorgen as one of their best motion systems manufacturing partners. Whether you are looking for classic servo motors, direct-drive servo motors, stepper motors, drives & amplifiers, gearing, actuation, or CNC & multi-axis motion controllers, Kollmorgen is one of the few companies in the world who actually designs and manufactures all of these products.

Our customers are leaders in many industries such as Aerospace & Defense, Printing, Packaging & Converting, Food & Beverage Processing, Medical Imaging, In Vitro Diagnostics & Laboratory Automation, Pharmaceutical Manufacturing, Material Forming and Cutting, Oil & Gas, and Robotics. Kollmorgen is also a leader in Warehouse Automation, including complete AGV systems, software, awareness and autonomy.

Our Automation Solutions can be found on Mars and in space, ships and submarines, O&G drilling and metrology, surgical robots and laser eye surgery, even inside artificial hearts. These are just a few applications that demand high-performance and high-quality while satisfying their specific needs.

Because motion matters, it's our focus: Motion can distinctly differentiate a machine and deliver a marketplace advantage by increasing its performance and dramatically improving overall equipment effectiveness (OEE).

High-performance motion can make your customer's machine more reliable and energy-efficient, enhance accuracy and improve operator safety. Motion also represents endless possibilities for innovation.

We've always understood this potential, and thus have kept motion at our core and in our Vision, Mission & Values, relentlessly developing products that offer precise control of torque, velocity and position accuracy in machines that rely on complex motion.

Removing the Barriers of Design, Sourcing, and Time

At Kollmorgen, we know that OEM engineers can achieve a lot more when obstacles aren't in the way. So, we clear obstacles in three important ways:

Integrating Standard and Custom Products

The optimal solution is often not clear-cut. Our application expertise allows us to modify standard products or develop totally custom solutions across our whole product portfolio so that designs can take flight.

Providing Motion Solutions, Not Just Components

As companies reduce their supplier base and have less engineering manpower, they need a total system supplier with a wide range of integrated solutions. Kollmorgen offers complete solutions as well as motion subsystems that combine programming software, engineering services and best-in-class motion components.

Global Footprint

With direct sales, engineering support, manufacturing facilities, and distributors spanning the Americas, Europe, Middle East, and Asia, we're close to OEMs worldwide. Our proximity helps speed delivery and lend support where and when they're needed.

Financial and Operational Stability

Kollmorgen is part of Fortive. A key driver in the growth of all Fortive divisions is the Fortive Business System, which relies on the principle of "kaizen" – or continuous improvement. Using world-class tools, cross-disciplinary teams of exceptional people evaluate processes and develop plans that result in superior performance.

Kollmorgen: Your partner. In Motion.

Table of Contents

▶ Direct Drive Rotary Motors	4
▶ Cartridge Direct Drive Rotary™ (DDR) Motor	6
Press Feed Machine Application	9
System Summary	10
C(H)04x, C(H)05x, C(H)06x, C(H)09x, C(H)13x	
Performance Data	12
C(H)04x, C(H)05x, C(H)06x, C(H)09x, C(H)13x	
Outline Drawings	28
C(H)04x, C(H)05x, C(H)06x, C(H)09x, C(H)13x	
Mounting Requirements	36
C(H)04x, C(H)05x, C(H)06x, C(H)09x, C(H)13x	
Cartridge DDR® Nomenclature	38
▶ AKD® Servo Drive	40
General Specification	43
Range of Coverage	44
Feedback and I/O	45
AKD® Servo Drive Nomenclature	46
▶ Motioneering® Online	47

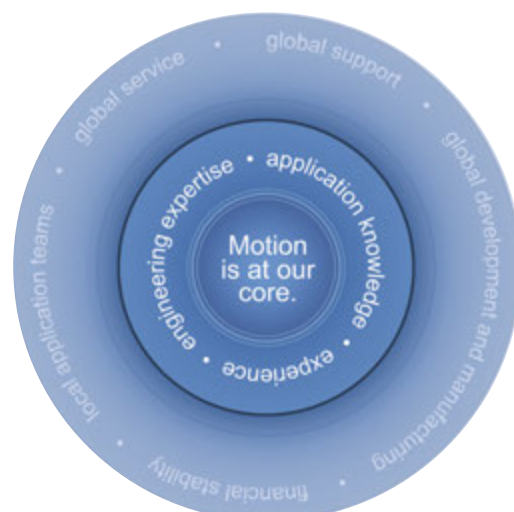

Direct Drive Rotary Motors

Conventional servo systems commonly have a mechanical transmission which can consist of gears, gearboxes, belts/pulleys or cams connected between the motor and the load. With Direct Drive Rotary Motors, the mechanical transmission is eliminated and the motor is coupled directly to the load.

Why Use Direct Drive Rotary Motors?

Increased Accuracy and Repeatability

A “precision” planetary gearbox could have a backlash of 1 arc-minute. This can result in the load moving by 1 arc-minute with an absolutely stationary drive motor. Kollmorgen’s standard direct drive rotary (DDR) servo motors have repeatability better than 1 arc-second. Therefore, a direct drive motor can hold a position 60 times better than a conventional motor/gearbox.

The increased accuracy of direct drive rotary motors results in a higher quality product out of the machine:

- Print registration is more accurate
- Cut or feed lengths can be held more precisely
- Coordination with other machine axes is more accurate
- Indexing location is more exact
- Tuning issues due to backlash are eliminated

Higher Bandwidth

Mechanical transmission components impose a limit on how fast a machine can start and stop and also extend the required settling time. These factors limit the possible throughput of a machine.

Direct drive rotary motors remove these limitations and allows for much faster start/stop cycles and also provide greatly reduced settling time. Machine users of direct drive systems have reported up to a 2X increase in throughput.

Improved Reliability and Zero Maintenance

Gears, belts, and other mechanical transmission parts break. By eliminating these parts and using DDR motors, the reliability of the machine is improved. Gearboxes require periodic lubrication and/or replacement in aggressive start/stop applications. Belts require periodic tightening. There are no time-wear components in a direct drive motor and consequently they require zero maintenance.

Fewer Parts

With direct drive motors, all you need is the motor and the mounting bolts. This often replaces many parts including brackets, guards, belts, pulleys, tensioners, couplings, and bolts, resulting in:

- Fewer parts on the BOM. Less parts to purchase, schedule, inventory and control, and less parts to assemble.
- Assembly time of the servo drops from several hours with the mechanical transmission to several minutes with the DDR.
- Reduced cost. Although a direct drive motor may carry a small price-premium compared to a motor/gearbox with the same torque, consider that there is an overall cost reduction when eliminating the parts and labor of all the extra components required in a servo system with mechanical transmission.

No Inertia Matching

Servo systems with mechanical transmissions require inertia matching that limits the reflected load inertia at 5 to 10 times the motor inertia. If this limitation is not met, the system becomes difficult to control due to instability issues. Inertia matching limitations of mechanical transmission systems often force machine designers to use a larger motor than would otherwise be required just to satisfy the inertia matching requirement.

Such sizing conventions are not required with direct drive rotary motors. Since the motor is directly connected to the load, the inertia of the motor and the load become a common inertia. Therefore, no inertia matching is required when using DDR. DDR applications have run with inertia ratios greater than 11,000:1.

Reduced Audible Noise

Machines with DDR motors have audible noise levels as low as 20 dB less than the same machine with a mechanical transmission.

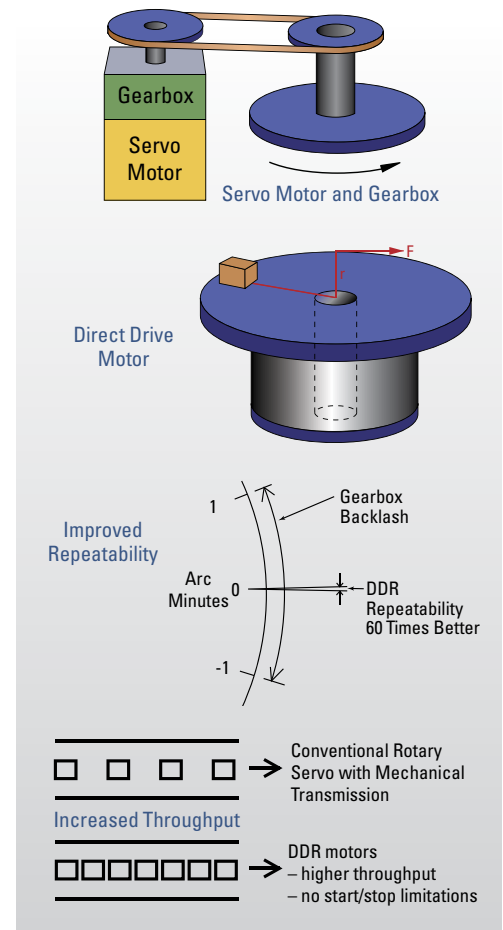

Which DDR Product is Right for Your Application?

Kollmorgen's 70 years of electromagnetic and electromechanical design experience combined with our quality and service, allowed us to refine and expand DDR motors into three product categories for easy installation, use, and short lead times: Frameless DDR, Housed DDR, and the Cartridge DDR™. This allows you to select the right DDR solution for your application.

Applications where the load rides on the motor's bearings such as indexing or rate tables



Cartridge DDR Motor

This motor is the first in the industry to combine the space-saving and performance advantages of Frameless DDR motors with the ease of installation of a full-frame motor. Consisting of a rotor, stator, and factory-aligned high-resolution feedback device, the motor uses the machine's bearings to support the rotor. An innovative compression coupling engages the rotor to the load and the frame of the motor mounts to the machine with a bolt circle and pilot diameter just like a conventional servo motor, saving space and design time and simplifying the overall system.

Any application with existing bearings

Housed DDR Motor

The Housed DDR is a housed motor assembly featuring a factory aligned high-resolution feedback device and precision bearings, allowing it to function as the core of rotary indexing and rate table applications. The system can also be used as a flexible indexer, providing programmable, rapid indexing far exceeding the throughput and accuracy of conventional mechanical or variable reluctance indexers.

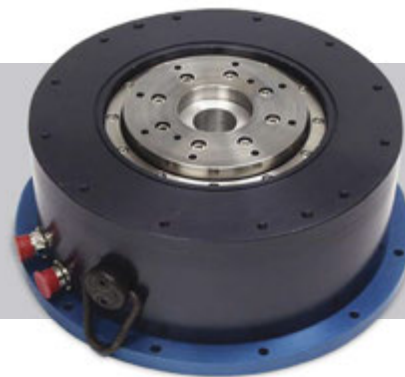

Applications where size and weight must be absolutely minimized



Frameless DDR Motors

Frameless motors include a rotor and stator as separate components which are integrated into, ride on the bearings of, and become a part of the driven load. Frameless motors offer the most compact and lightweight DDR solution available. The KBM™ and TBM series are Kollmorgen's Frameless DDR products. The KBM provides excellent torque/volume with the use of a proprietary neodymium-iron magnet rotor structure and skewed armature assembly. The KBM series is the first UL recognized parts set available on the market. This provides OEMs with the benefits of UL component ratings for easier agency approval on their machines. The TBM frameless motor is a series of direct drive torque motors designed for applications that require high power in a small, compact form factor with minimized weight and inertia.

Need a Solution for Linear Motion Applications?

Direct Drive Linear (DDL) Motor <http://www.kollmorgen.com/en-us/products/motors/direct-drive/direct-drive-linear/>

Directly coupling a linear motor to the driven load offers many advantages, including eliminating all mechanical transmissions, such as ball/lead screws, rack & pinions, belts/pulleys, and eliminating gearboxes. This in turn also eliminates backlash and compliance, and other problems associated with these mechanical transmissions.

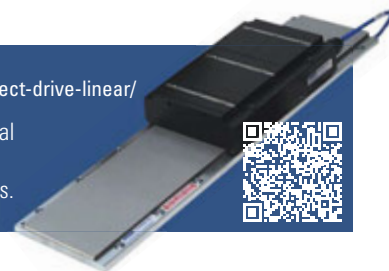

▶ Cartridge Direct Drive Rotary™ (DDR) Motor

The Cartridge DDR™ Motor is the first in the industry to combine the space-saving and performance advantages of frameless DDR technology with the ease of installation of a full-frame motor. Cartridge DDR motors also feature an advanced electromagnetic design that provides up to 50% more torque density than comparably sized conventional servo motors.

Consisting of a rotor, stator, factory-aligned high-resolution feedback device, the Cartridge DDR motor uses the machine's bearings to support the rotor. An innovative compression coupling secures the Cartridge DDR's rotor to the machine shaft, and the Cartridge DDR's housing is bolted to the machine frame with a bolt circle and pilot – just like a conventional servo motor. Also, mechanical transmission components are eliminated, saving space and design time while simplifying the overall system.

Cartridge DDR™ Motor Features

Benefits

- | | |
|--|---|
| <ul style="list-style-type: none"> • Integrated compression coupling and shipping hardware | <ul style="list-style-type: none"> • Eliminate parts and labor for a faster and lower cost machine build • Assembles in 5 minutes |
| <ul style="list-style-type: none"> • 5 frame sizes, multiple lengths • 230 / 400 / 480 Vac windings available (high and low) • Continuous torque range: 4.57 N-m (3.37 lb-ft) to 510 N-m (373 lb-ft) • Speeds up to 2,500 RPM • Optimized torque output with high-pole count efficient electromagnetic design • Hollow shaft available on C09x and C13x models, provides a 1.26 inch (32 mm) through bore to allow process or wiring to run through the center of the motor. Provision for mounting a rotary union to the shaft and housing is included. | <ul style="list-style-type: none"> • Satisfies a wide range of machine requirements and configurations |
| <ul style="list-style-type: none"> • Integrated high-resolution sine encoder • 134,217,728 counts / rev • Low cogging for smooth low-speed rotation • Zero backlash and compliance | <ul style="list-style-type: none"> • Increased accuracy and higher throughput |
| <ul style="list-style-type: none"> • Direct load connection eliminates gearboxes, belts, or pulleys | <ul style="list-style-type: none"> • Greater machine reliability and reduced maintenance • Reduced audible noise, fewer parts and lower cost of ownership • More compact machine and reduced design time |

Cartridge DDR™ Motor

Cartridge DDR Application Considerations

Inertia Matching

Since the Cartridge DDR motor is directly connected to the machine, inertial matching is not required as it is on a conventional motor. With direct drive, inertia miss match of 250 to 1 is common and miss match of 1000 to 1 has been demonstrated.

Mounting Orientation

The Cartridge DDR motor can be mounted with any orientation including either a horizontal or vertical shaft.

Mounting Cartridge DDR to Machine

Simple and quick procedures to mount:

- Slide the Cartridge DDR motor onto machine shaft
- Bolt Cartridge DDR motor housing to machine frame
- Torque compression coupling
- Remove/store shipping hardware
- Connect cables and run the motor



Proprietary electromagnetic design gives Cartridge DDR motors more torque per volume than conventional DDR technology.

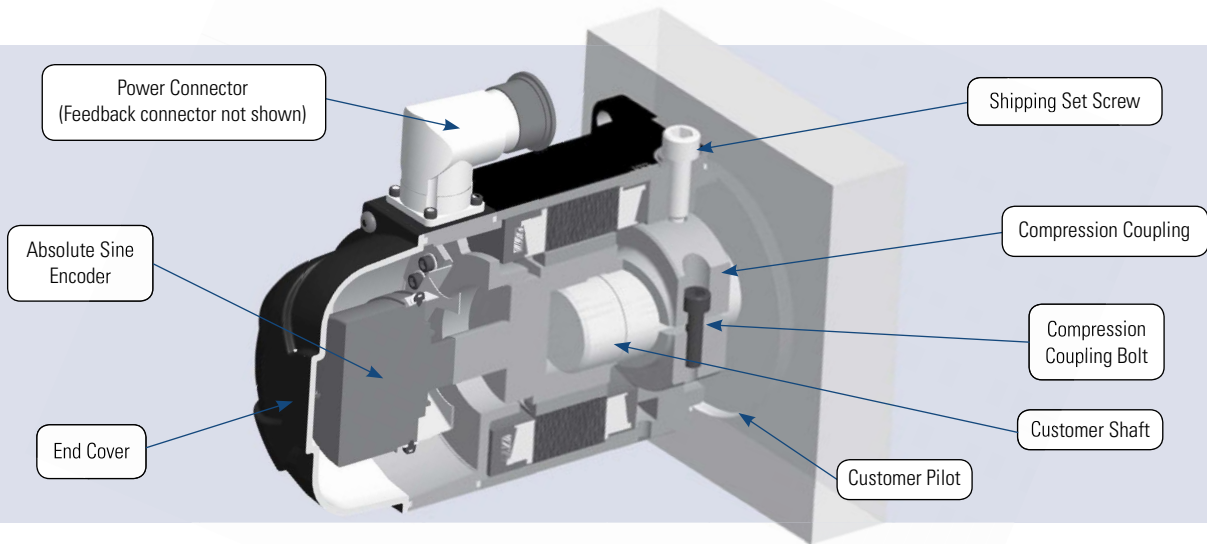
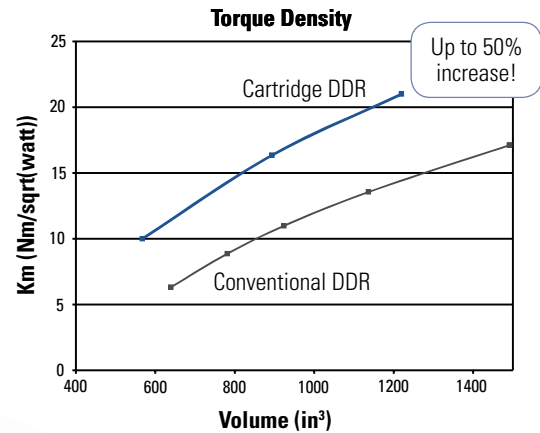

The Cartridge DDR™ Advantage – Press Feed Machine

Consider how Cartridge DDR technology improves a Press Feed machine:

Reduced Assembly Time

The assembly time for the original mechanical transmission system was 4 hours. In contrast, the Cartridge DDR motor is installed in less than 5 minutes, resulting in a significant cost savings in labor.

Reduced Parts Count

The original mechanical transmission system comprises 2 bracket pieces, 12 bolts, 2 pulleys, 2 set screws, 2 keys, a timing belt, a housing to protect operators from the timing belt, a tension system for the timing belt, and motor/gearbox. With the Cartridge DDR system, this is all replaced by the motor and 4 mounting bolts, resulting in fewer parts to maintain and cost savings.

Improved Accuracy

The best planetary gearboxes have a backlash between 1 and 2 arc-minutes. Over the life of the gearbox, the backlash will increase. The Cartridge DDR system has an absolute accuracy of 26 arc-seconds and a repeatability of 0.7 arc-seconds. The Press Feed machine with the Cartridge DDR has a feed accuracy of +/- 0.0005 inch where the Press Feed machine with the mechanical transmission has a feed accuracy of 0.002 inch. Therefore, there was an overall four times improvement in machine accuracy with the Cartridge DDR system.

Increased Throughput

The cycle rate of the Cartridge DDR system is two times better than the mechanical transmission. This results in an increase in throughput of 100 percent.

Improved Reliability and Simplified Maintenance

The Cartridge DDR system eliminates parts that wear, change over time, or fail. Gearboxes are prone to wear, and backlash increases over time. Belts and pulleys stretch and require maintenance to maintain proper belt tension. By eliminating these components, the Cartridge DDR system delivers greater system reliability.

Press Feed Example

Gearboxes have a finite life span, especially in a demanding cyclic application such as a Press Feed. On this machine, the gearbox must be replaced every 10,000 hours and the belt must be tensioned every 2,000 hours. By contrast, the Cartridge DDR motor has no wear components and requires no maintenance thus simplifying the maintenance schedule for the machine and reducing operating costs.

Reduced Audible Noise

The Cartridge DDR system has as much as a 20 dB reduction in noise compared to a mechanical transmission servo system. This can dramatically reduce the overall noise level of the machine. A quieter machine gives the perception of quality. This is rightfully so as the noise emitted by gears and belts is caused by the wearing of the parts.

Total Reduced Cost

A Cartridge DDR motor typically costs 20 percent more than a comparable motor/gearbox combination. However, the elimination of parts and assembly time typically results in a lower total cost for the Cartridge DDR solution.



Press feed machine built with a conventional servo motor, gearbox, belt and pulleys.

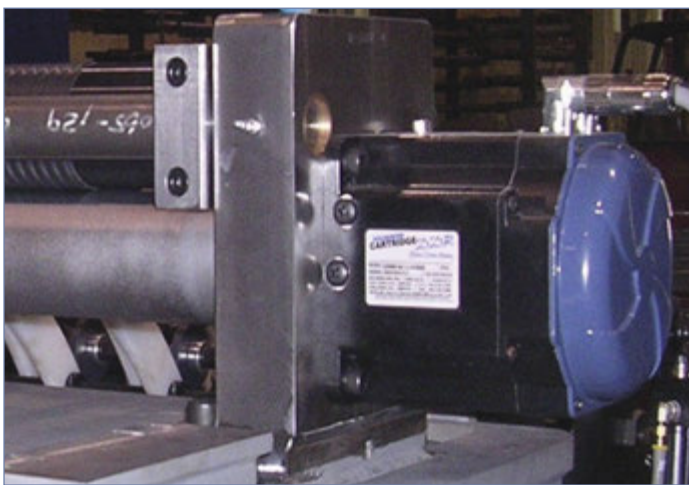

Same machine with a Cartridge DDR motor installed. Here, the shaft of the driven roll is extended into the Cartridge DDR motor and the motor applies torque directly to the driven roll.

Cartridge DDR™ System Summary

Due to the large range of continuous and peak torques for the Cartridge DDR series, the mechanical mounting and coupling to the machine varies.

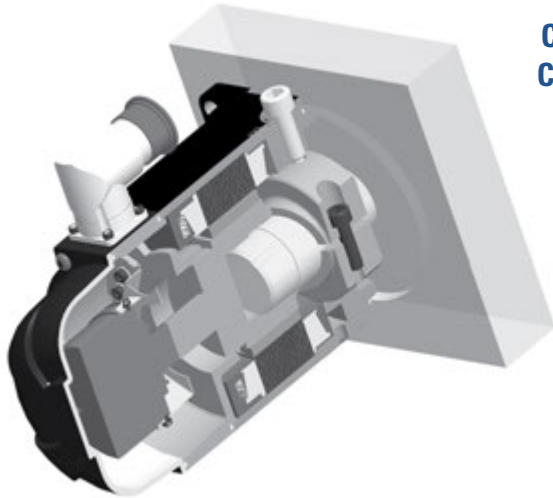

**Cross Section of
C(H)04x, C(H)05x,
C(H)06x**

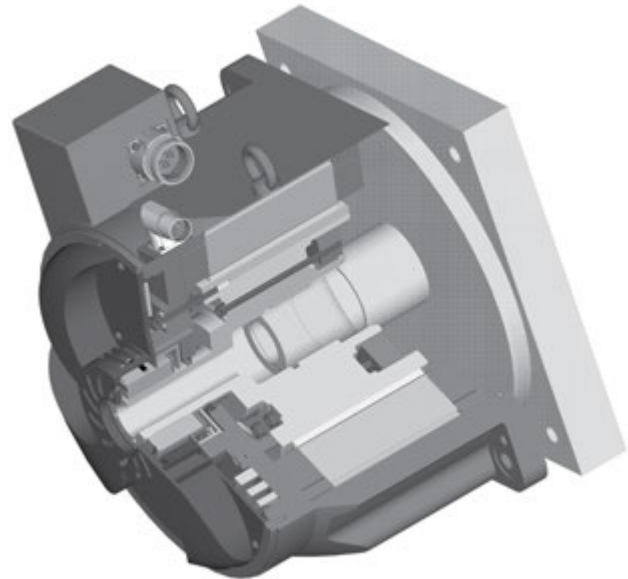

**Cross Section of
C(H)09x, C(H)13x**

Machine Interface Summary

Parameter	C(H)04x, C(H)05x, C(H)06x	C(H)09x, C(H)13x
Coupling Technology	Single bolt split hub, access front motor	Multi-bolt compression, access from rear of motor
Mounting Requirements Shaft TIR	.005" (.13 mm)	.0015" (.038 mm)
Perpendicularity of Machine Mounting Face	.004" (.10 mm)	.002" (.051 mm)
Concentricity of Machine Pilot to Shaft	.004" (.10 mm)	.002" (.051 mm)
Shipping Hardware	Alignment bolt and cap screw	4 set screws and 4 shipping bolts
Mounting Procedure	Procedure # 903-700001-99	Procedure # 903-700001-99

Performance Summary

		AKD Servo Drive					Performance					
		AKD-x0030X	AKD-x0060X	AKD-x0120X	AKD-x0240X	AKD-x04807	Cont. Torque		Peak Torque		Maximum Speed	
							(N-m)	lb-ft	(N-m)	lb-ft		
Cartridge DDR Motors	240 Volt Systems	C041A	•				4.57	3.37	12.3	9.09	1750	
		C041B		•			4.52	3.33	12.2	9.01	2500	
		C042A		•			8.25	6.08	22.2	16.4	1700	
		C042B			•		8.45	6.23	22.8	16.8	2500	
		C043A		•			11.1	8.20	30.0	22.1	1250	
		C043B			•		11.2	8.23	30.2	22.2	2500	
		C044A		•			13.9	10.3	37.4	27.6	1050	
		C044B			•		14.1	10.4	37.9	28.0	2150	
		C051A		•			11.7	8.66	30.2	22.3	1200	
		C051B			•		11.9	8.77	30.6	22.6	2450	
		C052C		•			16.9	12.5	43.1	31.8	950	
		C052D			•		16.5	12.2	42.3	31.5	2050	
		C053A			•		21.0	15.5	54.1	39.9	1350	
		C053B				•	20.2	14.9	50.1	37.0	2500	
		C054A			•		24.9	18.4	63.8	47.1	1200	
		C054B				•	23.8	17.6	61.2	45.1	2350	
		C061A			•		33.8	24.9	86.8	64.1	900	
		C061B				•	32.6	24.1	75.6	55.7	1950	
		C062C			•		48.4	35.7	117	86.5	700	
		C062B				•	44.6	32.9	102	75.2	1400	
		C063C			•		61.8	45.6	157	115	550	
		C063B				•	59.0	43.5	136	100	1050	
		C091A				•	50.2	37.0	120	88.2	600	
		C092C				•	102	74.9	231	170	450	
		C093C				•	139	103	317	233	350	
		C131C				•	189	139	395	291	250	
		C131B					•	190	140	396	292	450
		C132C				•	362	267	818	603	120	
		C132B					•	361	266	759	560	225
		C133C				•	499	368	1070	791	100	
C133B					•	510	376	1016	749	175		
400 / 480 Volt Systems	CH041A	•				4.56	3.37	11.3	8.33	2500		
	CH042A		•			8.26	6.09	19.0	14.0	2500		
	CH043A		•			11.1	8.20	25.3	18.7	2500 ¹		
	CH044A		•			13.9	10.2	31.6	23.3	2250 ¹		
	CH051A	•				11.7	8.66	28.0	20.7	2500 ¹		
	CH052C	•				16.9	12.5	43.1	31.8	2100		
	CH053A		•			21.0	15.5	54.1	39.9	2500 ¹		
	CH054A		•			24.9	18.4	63.8	47.1	2500 ¹		
	CH061A		•			33.8	24.9	86.8	64.1	1900 ¹		
	CH062C		•			48.4	35.7	117	86.5	1550 ¹		
	CH063C		•			61.8	45.6	157	115	1150 ¹		
	CH063B			•		59.0	43.5	136	100	2200 ¹		
	CH091A			•		50.2	37.0	120	88.2	1500 ¹		
	CH092C			•		102	74.9	231	170	1000 ¹		
	CH093C			•		139	103	317	233	800 ¹		
	CH131C				•	189	139	395	291	600 ¹		
	CH131B					•	190	140	396	292	1000 ¹	
	CH132C				•	362	267	818	603	300 ¹		
	CH132B					•	361	266	759	560	500 ¹	
	CH133C				•	499	368	1070	791	250 ¹		
CH133B					•	510	376	1016	749	400 ¹		

1. Maximum speed at 480 Vac. For maximum speed at 400 Vac see performance curve.

Cartridge DDR™ Performance Data

C04xA

System Performance at 240 VAC C04xA Cartridge DDR™ Motor with AKD® Servo Drive Series Amplifier

System Performance	Symbol	Units	C041A	C042A	C043A	C044A
Continuous Torque 100°C Rise ^{1,2,3}	T _c	lb-ft (N-m)	3.37 (4.57)	6.08 (8.25)	8.20 (11.1)	10.3 (13.9)
Cont. Line Current	I _c	amps RMS	2.73	4.68	4.73	4.91
Continuous Torque 70°C Rise ^{1,2,3}	T _c	lb-ft (N-m)	2.93 (3.97)	5.30 (7.19)	7.14 (9.68)	9.14 (12.4)
Cont. Line Current	I _c	amps RMS	2.38	4.08	4.13	4.37
Peak Torque	T _p	lb-ft (N-m)	9.09 (12.3)	16.4 (22.2)	22.1 (30.0)	27.6 (37.4)
Peak Line Current	I _p	amps RMS	8.20	14.0	14.2	14.7
Maximum Speed	N max	RPM	1750	1700	1250	1050
Weight	Wt	lb (kg)	9.00 (4.08)	12.5 (5.67)	16.0 (7.26)	19.5 (8.84)
Rotor Inertia	J _m	oz-in-sec ² (kg-cm ²)	0.083 (5.86)	0.126 (8.87)	0.168 (11.9)	0.211 (14.9)

CARTRIDGE DDR™ PERFORMANCE DATA

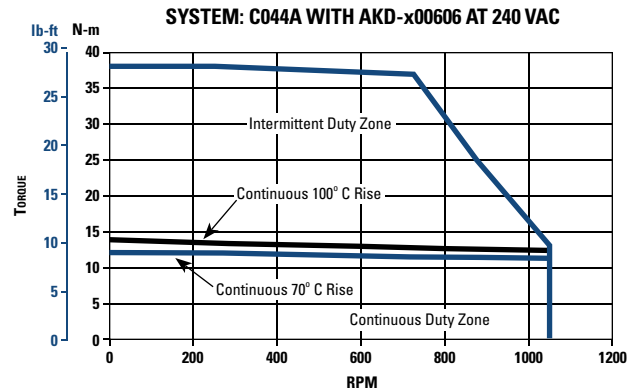
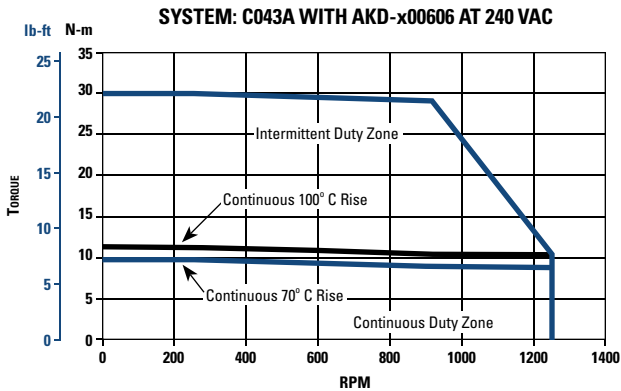
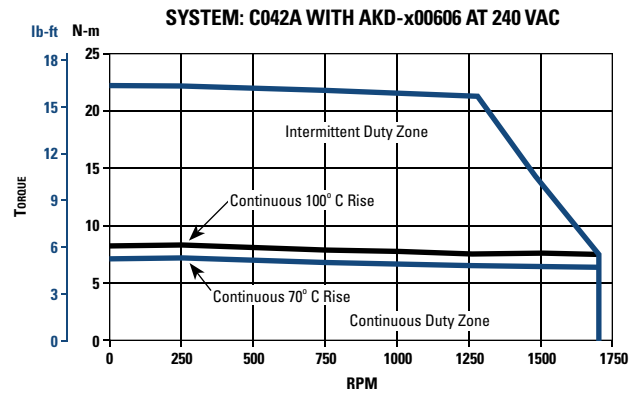
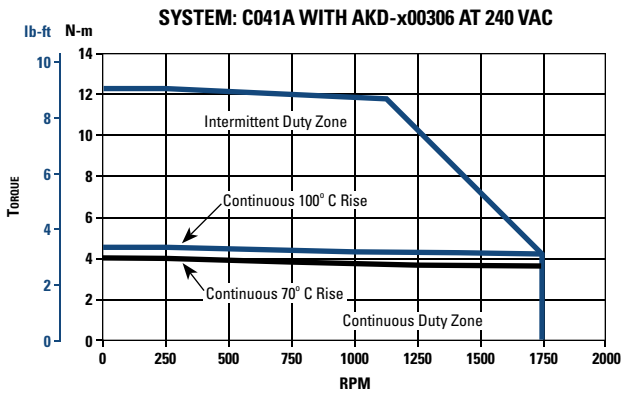

- Notes:
1. At 40°C ambient.
 2. Increase T_c by 1.06 times for 25°C ambient.
 3. Temperature rise assumes a 12 x 12 x 0.50 inch aluminum mounting plate or equivalent.

CH04xA

System Performance at 400/480 VAC CH04xA Cartridge DDR™ Motor with AKD® Servo Drive Series Amplifier

System Performance	Symbol	Units	CH041A	CH042A	CH043A	CH044A
Continuous Torque 100°C Rise ^{1,2,3}	Tc	lb-ft (N-m)	3.37 (4.56)	6.09 (8.26)	8.20 (11.1)	10.2 (13.9)
Cont. Line Current	Ic	amps RMS	2.73	4.68	4.73	4.90
Continuous Torque 70°C Rise ^{1,2,3}	Tc	lb-ft (N-m)	2.93 (3.97)	5.30 (7.19)	7.14 (9.68)	9.14 (12.4)
Cont. Line Current	Ic	amps RMS	2.38	4.08	4.13	4.30
Peak Torque	Tp	lb-ft (N-m)	8.33 (11.3)	14.0 (19.0)	18.7 (25.3)	23.3 (31.6)
Peak Line Current	Ip	amps RMS	7.50	12.0	12.0	12.0
Maximum Speed (400 V) Maximum Speed (480 V)	N max	RPM	2500 2500	2500 2500	2250 2500	1850 2250
Weight	Wt	lb (kg)	9.00 (4.08)	12.5 (5.67)	16.0 (7.26)	19.5 (8.84)
Rotor Inertia	Jm	oz-in-sec ² (kg-cm ²)	0.083 (5.86)	0.126 (8.87)	0.168 (11.9)	0.211 (14.9)

CARTRIDGE DDR™ PERFORMANCE DATA

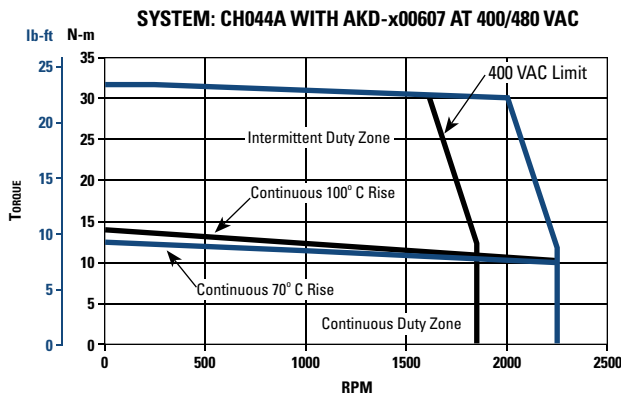
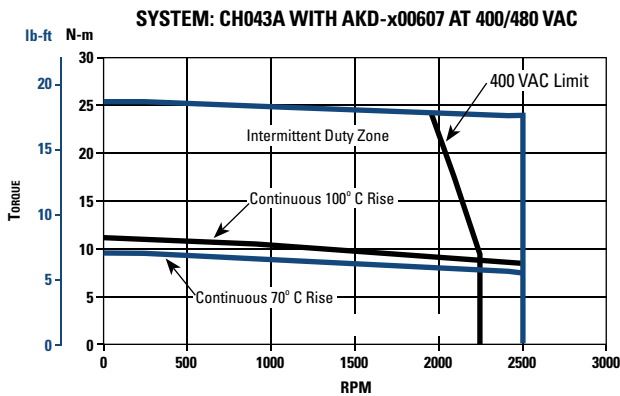
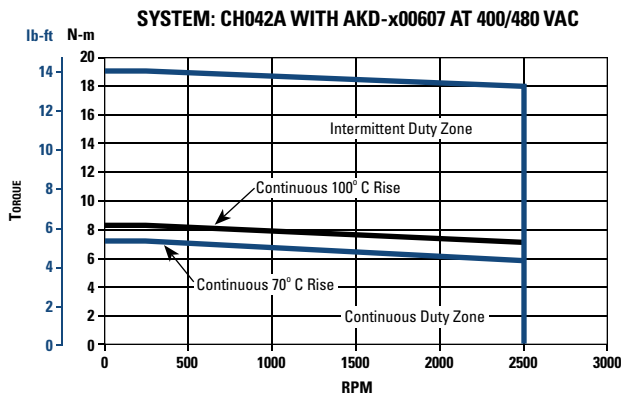
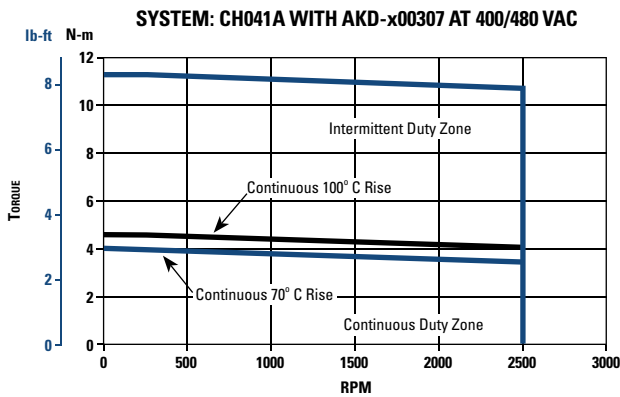

- Notes:
- At 40°C ambient.
 - Increase Tc by 1.06 times for 25°C ambient.
 - Temperature rise assumes a 12 x 12 x 0.50 inch aluminum mounting plate or equivalent.

*Complete CDDR series model nomenclature can be found on page 38.

Cartridge DDR™ Performance Data

C04xB

System Performance at 240 VAC C04xB Cartridge DDR™ Motor (High-Speed Winding) with AKD® Servo Drive Series Amplifiers

System Performance	Symbol	Units	C041B	C042B	C043B	C044B
Continuous Torque 100°C Rise ^{1,2,3}	T _c	lb-ft (N-m)	3.33 (4.52)	6.23 (8.45)	8.23 (11.2)	10.4 (14.1)
Cont. Line Current	I _c	amps RMS	4.69	9.19	9.15	9.53
Continuous Torque 70°C Rise ^{1,2,3}	T _c	lb-ft (N-m)	2.91 (3.94)	5.43 (7.36)	7.17 (9.73)	9.22 (12.5)
Cont. Line Current	I _c	amps RMS	4.09	8.01	7.98	8.50
Peak Torque	T _p	lb-ft (N-m)	9.01 (12.2)	16.8 (22.8)	22.2 (30.2)	28.0 (37.9)
Peak Line Current	I _p	amps RMS	14.1	27.6	27.5	28.6
Maximum Speed	N max	RPM	2500	2500	2500	2150
Weight	Wt	lb (kg)	9.00 (4.08)	12.5 (5.67)	16.0 (7.26)	19.5 (8.84)
Rotor Inertia	J _m	oz-in-sec ² (kg-cm ²)	0.083 (5.86)	0.126 (8.87)	0.168 (11.9)	0.211 (14.9)

CARTRIDGE DDR™ PERFORMANCE DATA

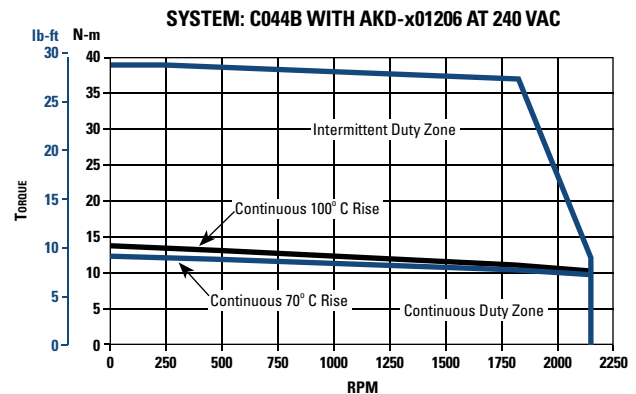
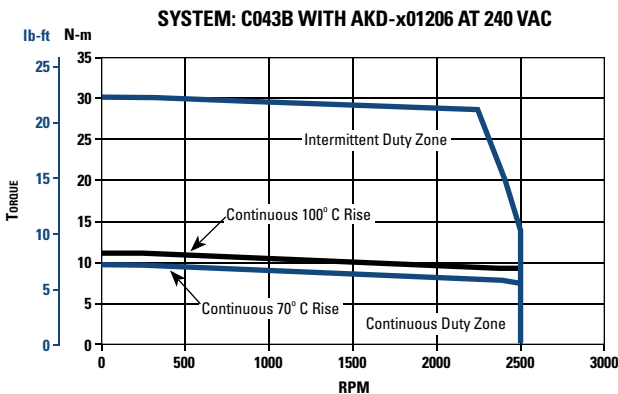
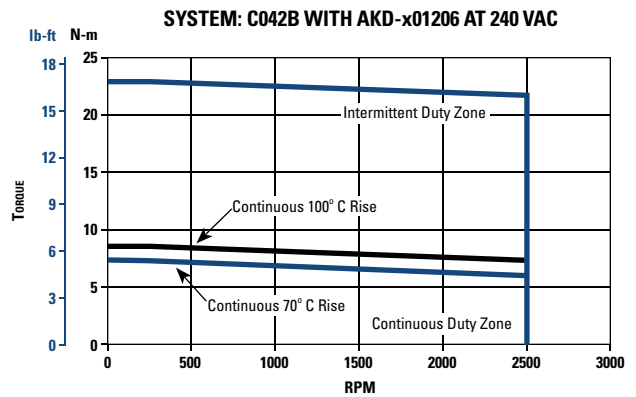
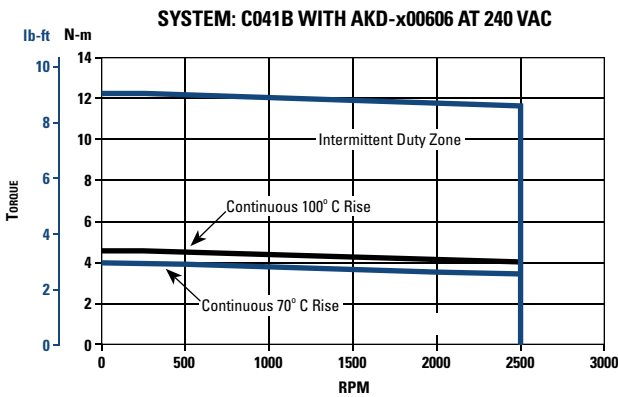

- Notes:
- At 40°C ambient.
 - Increase T_c by 1.06 times for 25°C ambient.
 - Temperature rise assumes a 12 x 12 x 0.50 inch aluminum mounting plate or equivalent.

C05xA/C

System Performance at 240 VAC C05xA/C Cartridge DDR™ Motor with AKD® Servo Drive Series Amplifiers

System Performance	Symbol	Units	C051A	C052C	C053A	C054A
Continuous Torque 100°C Rise ^{1,2,3}	Tc	lb-ft (N-m)	8.66 (11.7)	12.5 (16.9)	15.5 (21.0)	18.4 (24.9)
Cont. Line Current	Ic	amps RMS	4.78	5.73	9.28	9.82
Continuous Torque 70°C Rise ^{1,2,3}	Tc	lb-ft (N-m)	7.54 (10.2)	10.8 (14.7)	13.5 (18.3)	16.1 (21.8)
Cont. Line Current	Ic	amps RMS	4.17	5.00	8.10	8.62
Peak Torque	Tp	lb-ft (N-m)	22.3 (30.2)	31.8 (43.1)	39.9 (54.1)	47.1 (63.8)
Peak Line Current	Ip	amps RMS	12.9	15.5	25.1	26.5
Maximum Speed	N max	RPM	1200	950	1350	1200
Weight	Wt	lb (kg)	18.5 (8.39)	23.5 (10.7)	29.0 (13.2)	34.0 (15.4)
Rotor Inertia	Jm	oz-in-sec ² (kg-cm ²)	0.388 (27.4)	0.508 (35.9)	0.628 (44.3)	0.748 (52.8)

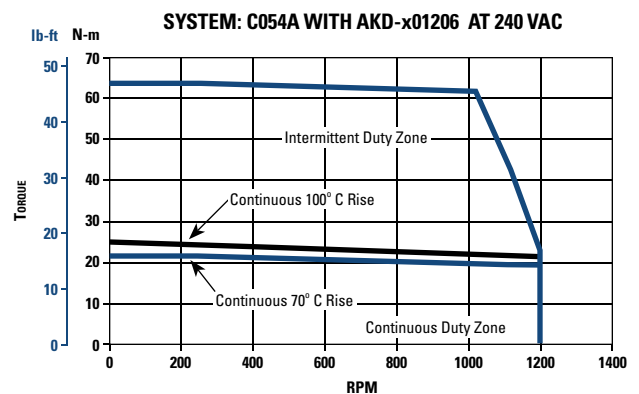
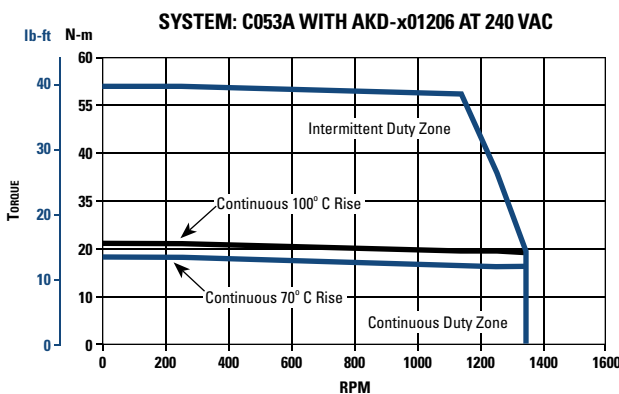
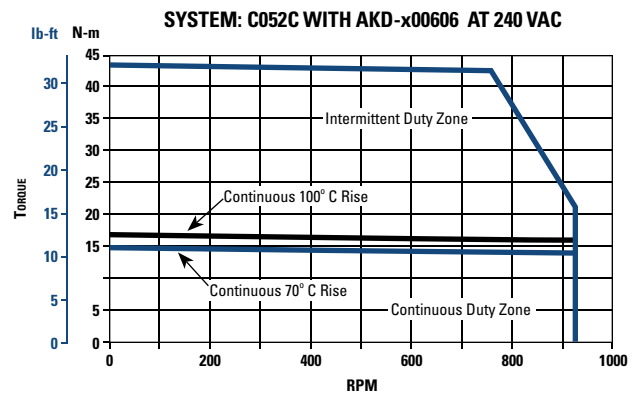
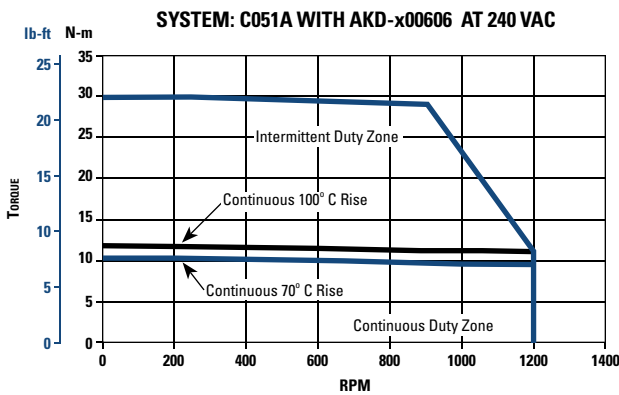

- Notes:
- At 40°C ambient.
 - Increase Tc by 1.06 times for 25°C ambient.
 - Temperature rise assumes a 18 x 18 x 0.50 inch aluminum mounting plate or equivalent.

*Complete CDDR series model nomenclature can be found on page 38.

Cartridge DDR™ Performance Data

CH05xA

System Performance at 400/480 VAC CH05xA/C Cartridge DDR™ Motor with AKD® Servo Drive Series Amplifiers

System Performance	Symbol	Units	CH051A	CH052C	CH053A	CH054A
Continuous Torque 100°C Rise ^{1,2,3}	T _c	lb-ft (N-m)	8.66 (11.7)	12.5 (16.9)	15.5 (21.0)	18.4 (24.9)
Cont. Line Current	I _c	amps RMS	4.78	5.73	9.28	9.82
Continuous Torque 70°C Rise ^{1,2,3}	T _c	lb-ft (N-m)	7.54 (10.2)	10.8 (14.7)	13.5 (18.3)	16.1 (21.8)
Cont. Line Current	I _c	amps RMS	4.17	5.00	8.10	8.62
Peak Torque	T _p	lb-ft (N-m)	20.7 (28.0)	31.8 (43.1)	39.9 (54.1)	47.1 (63.8)
Peak Line Current	I _p	amps RMS	12.0	15.5	25.1	26.5
Maximum Speed (400 V) Maximum Speed (480 V)	N max	RPM	2100 2500	1750 2100	2350 2500	2100 2500
Weight	Wt	lb (kg)	18.5 (8.39)	23.5 (10.7)	29.0 (13.2)	34.0 (15.4)
Rotor Inertia	J _m	oz-in-sec ² (kg-cm ²)	0.388 (27.4)	0.508 (35.9)	0.628 (44.3)	0.748 (52.8)

CARTRIDGE DDR™ PERFORMANCE DATA

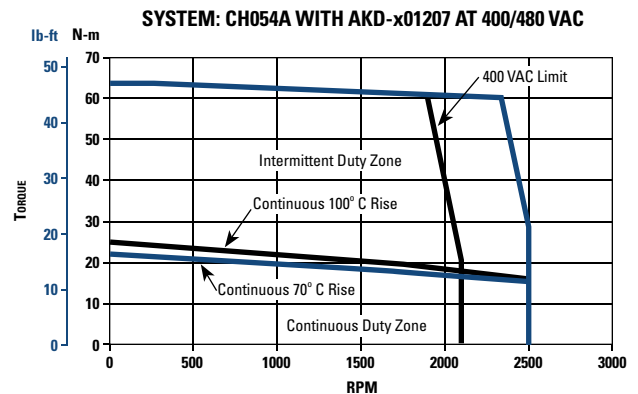
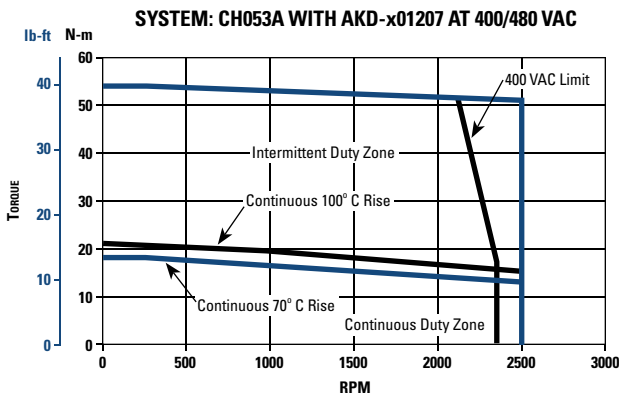
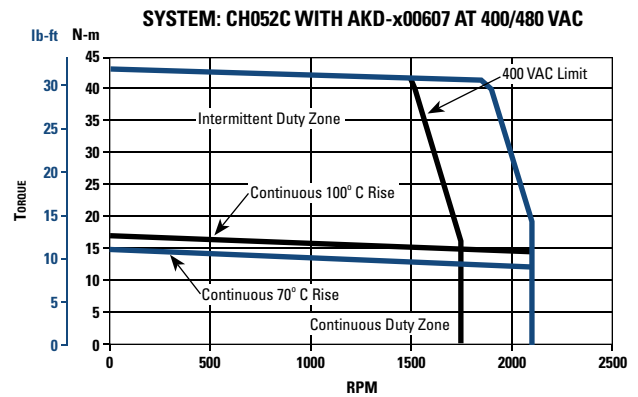
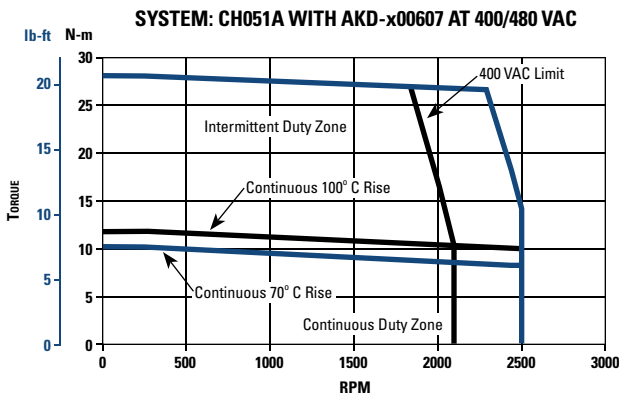

- Notes:
1. At 40°C ambient.
 2. Increase T_c by 1.06 times for 25°C ambient.
 3. Temperature rise assumes a 18 x 18 x 0.50 inch aluminum mounting plate or equivalent.

C05xB/D

System Performance at 240 VAC C05xB/D Cartridge DDR™ Motor (High-Speed Winding) with AKD® Servo Drive Series Amplifiers

System Performance	Symbol	Units	C051B	C052D	C053B	C054B
Continuous Torque 100°C Rise ^{1,2,3}	Tc	lb-ft (N-m)	8.77 (11.9)	12.2 (16.5)	14.9 (20.2)	17.6 (23.8)
Cont. Line Current	lc	amps RMS	9.34	10.9	18.4	17.4
Continuous Torque 70°C Rise ^{1,2,3}	Tc	lb-ft (N-m)	7.63 (10.4)	10.6 (14.4)	12.9 (17.6)	15.4 (20.9)
Cont. Line Current	lc	amps RMS	8.15	9.55	16.0	15.3
Peak Torque	Tp	lb-ft (N-m)	22.6 (30.6)	31.2 (42.3)	37.0 (50.1)	45.1 (61.2)
Peak Line Current	lp	amps RMS	25.2	29.6	48.0	47.0
Maximum Speed	N max	RPM	2450	2050	2500	2350
Weight	Wt	lb (kg)	18.5 (8.39)	23.5 (10.7)	29.0 (13.2)	34.0 (15.4)
Rotor Inertia	Jm	oz-in-sec ² (kg-cm ²)	0.388 (27.4)	0.508 (35.9)	0.628 (44.3)	0.748 (52.8)

CARTRIDGE DDR™ PERFORMANCE DATA

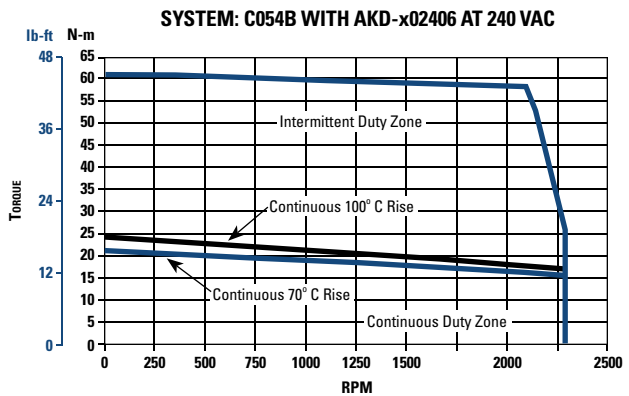
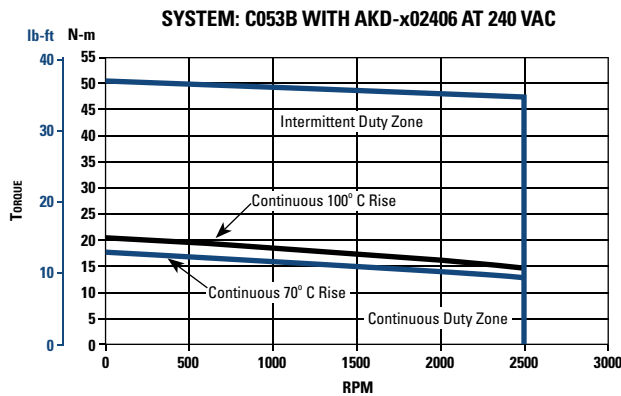
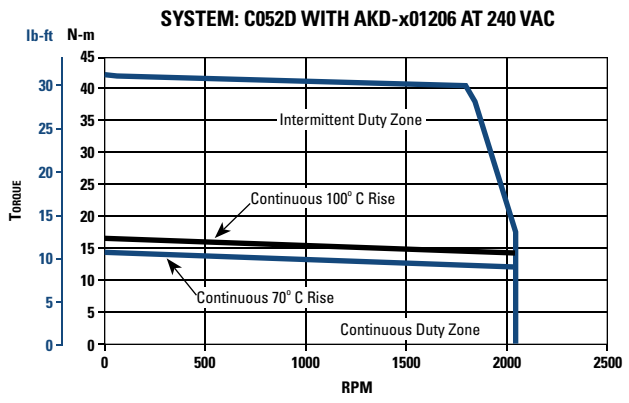
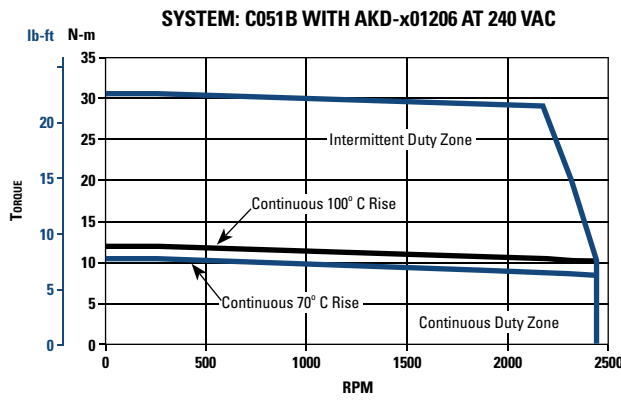

- Notes:
- At 40°C ambient.
 - Increase Tc by 1.06 times for 25°C ambient.
 - Temperature rise assumes a 18 x 18 x 0.50 inch aluminum mounting plate or equivalent.

*Complete CDDR series model nomenclature can be found on page 38.

Cartridge DDR™ Performance Data

C06xA/C

System Performance at 240 VAC C06xA/C Cartridge DDR™ Motor with AKD® Servo Drive Series Amplifiers

System Performance	Symbol	Units	C061A	C062C	C063C
Continuous Torque 100°C Rise ^{1,2,3}	T _c	lb-ft (N-m)	24.9 (33.8)	35.7 (48.4)	45.6 (61.8)
Cont. Line Current	I _c	amps RMS	10.0	11.8	11.3
Continuous Torque 70°C Rise ^{1,2,3}	T _c	lb-ft (N-m)	21.7 (29.4)	31.1 (42.2)	39.7 (53.9)
Cont. Line Current	I _c	amps RMS	8.72	10.3	9.84
Peak Torque	T _p	lb-ft (N-m)	64.1 (86.8)	86.5 (117)	115 (157)
Peak Line Current	I _p	amps RMS	27.0	30.0	30.0
Maximum Speed	N max	RPM	900	700	550
Weight	Wt	lb (kg)	41.0 (18.6)	52.0 (23.6)	63.0 (29.0)
Rotor Inertia	Jm	oz-in-sec ² (kg-cm ²)	1.33 (94.1)	1.78 (126)	2.23 (157)

CARTRIDGE DDR™ PERFORMANCE DATA

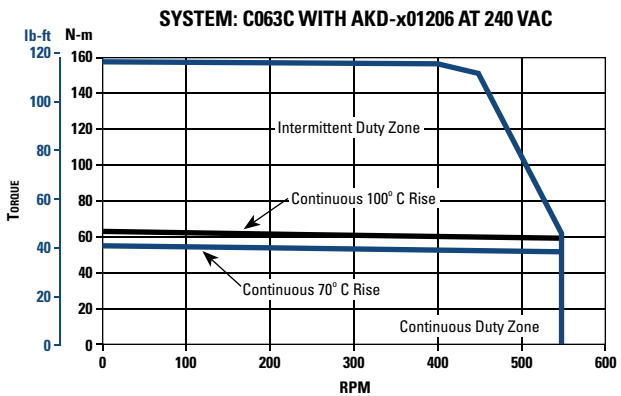
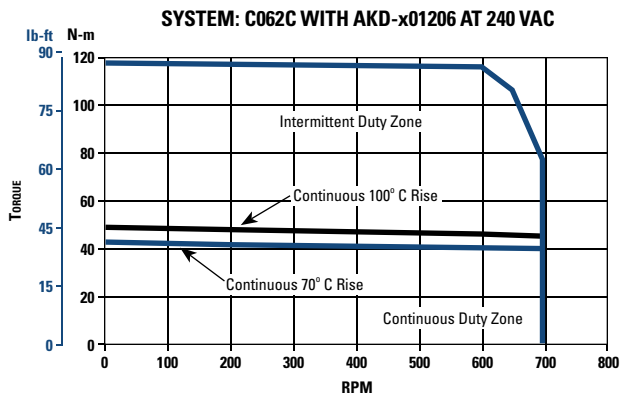
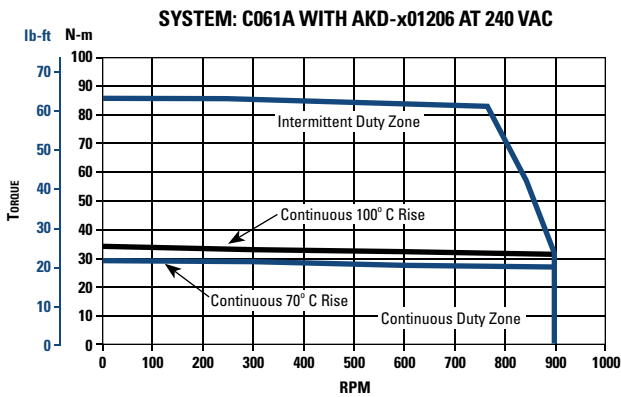

- Notes:
1. At 40°C ambient.
 2. Increase T_c by 1.06 times for 25°C ambient.
 3. Temperature rise assumes a 18 x 18 x 0.50 inch aluminum mounting plate or equivalent.

CH06x

System Performance at 400 / 480 VAC CH06x Cartridge DDR™ Motor with AKD® Servo Drive Series Amplifier

System Performance	Symbol	Units	CH061A	CH062C	CH063C	CH063B
Continuous Torque 100°C Rise ^{1,2,3}	T _c	lb-ft (N-m)	24.9 (33.8)	35.7 (48.4)	45.6 (61.8)	43.5 (59.0)
Cont. Line Current	I _c	amps RMS	10.0	11.8	11.3	19.8
Continuous Torque 70°C Rise ^{1,2,3}	T _c	lb-ft (N-m)	21.7 (29.4)	31.1 (42.2)	39.7 (53.9)	37.9 (51.4)
Cont. Line Current	I _c	amps RMS	8.72	10.3	9.84	17.3
Peak Torque	T _p	lb-ft (N-m)	64.1 (86.8)	86.5 (117)	115 (157)	100 (136)
Peak Line Current	I _p	amps RMS	27.0	30.0	30.0	48.0
Maximum Speed (400 V) Maximum Speed (480 V)	N max	RPM	1600 1900	1250 1550	950 1150	1850 2200
Weight	Wt	lb (kg)	41.0 (18.6)	52.0 (23.6)	63.0 (29.0)	63.0 (29.0)
Rotor Inertia	J _m	oz-in-sec ² (kg-cm ²)	1.33 (94.1)	1.78 (126)	2.23 (157)	2.23 (157)

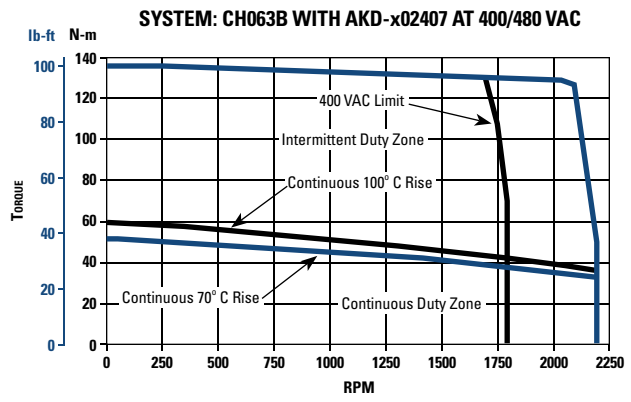
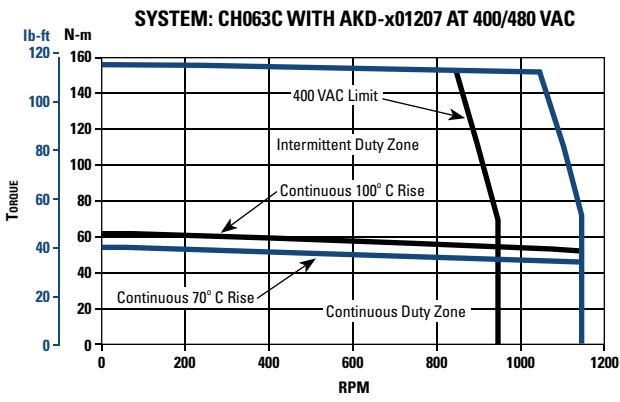
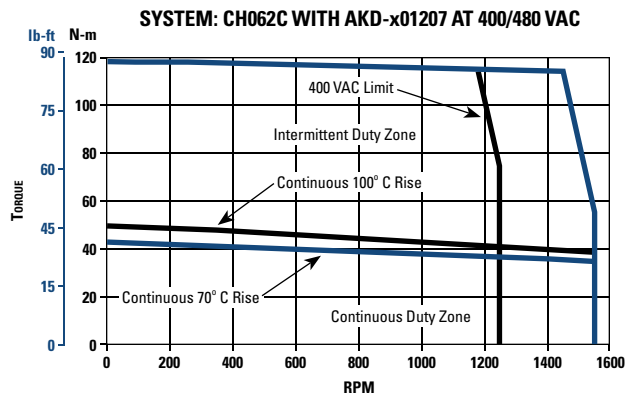
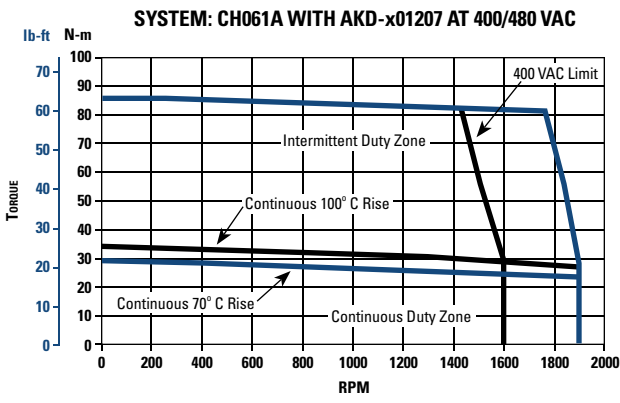

- Notes:
- At 40°C ambient.
 - Increase T_c by 1.06 times for 25°C ambient.
 - Temperature rise assumes a 18 x 18 x 0.50 inch aluminum mounting plate or equivalent.

*Complete CDDR series model nomenclature can be found on page 38.

Cartridge DDR™ Performance Data

C06xB

System Performance at 240 VAC C06xB Cartridge DDR™ Motor (High-Speed Winding) with AKD® Servo Drive Series Amplifier

System Performance	Symbol	Units	C061B	C062B	C063B
Continuous Torque 100°C Rise ^{1,2,3}	T _c	lb-ft (N-m)	24.1 (32.6)	32.9 (44.6)	43.5 (59.0)
Cont. Line Current	I _c	amps RMS	19.7	20.0	19.8
Continuous Torque 70°C Rise ^{1,2,3}	T _c	lb-ft (N-m)	21.0 (28.4)	29.9 (40.5)	37.9 (51.4)
Cont. Line Current	I _c	amps RMS	17.2	18.2	17.3
Peak Torque	T _p	lb-ft (N-m)	55.7 (75.6)	75.2 (102)	100 (136)
Peak Line Current	I _p	amps RMS	48.0	48.0	48.0
Maximum Speed	N max	RPM	1950	1400	1050
Weight	W _t	lb (kg)	41.0 (18.6)	52.0 (23.6)	63.0 (29.0)
Rotor Inertia	J _m	oz-in-sec ² (kg-cm ²)	1.33 (94.1)	1.78 (126)	2.23 (157)

CARTRIDGE DDR™ PERFORMANCE DATA

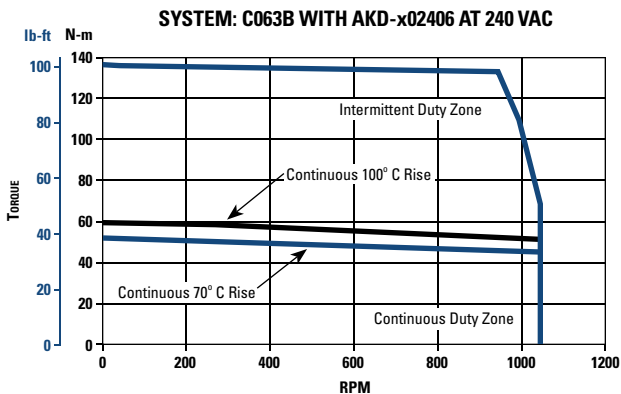
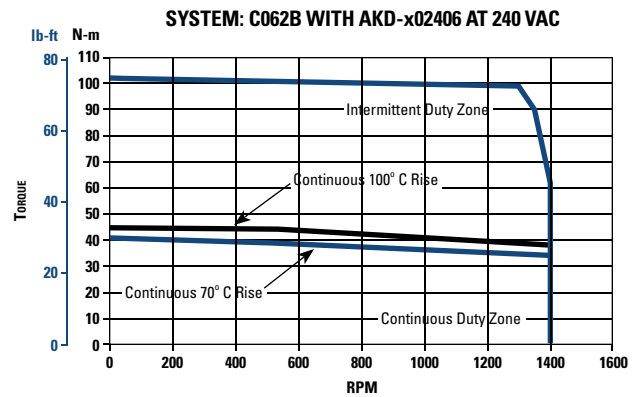
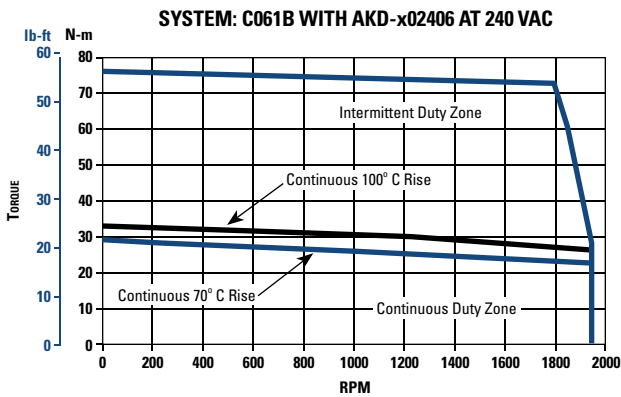

- Notes:
- At 40°C ambient.
 - Increase T_c by 1.06 times for 25°C ambient.
 - Temperature rise assumes a 18 x 18 x 0.50 inch aluminum mounting plate or equivalent.

C09xA/C

System Performance at 230 VAC C09xA/C Cartridge DDR™ Motor with AKD® Drive Amplifiers

System Performance	Symbol	Units	C091A	C092C	C093C
Continuous Torque 110°C Rise ^{1,2,3}	T _c	lb-ft (N-m)	37.0 (50.2)	74.9 (102)	103 (139)
Cont. Line Current	I _c	amps RMS	12.8	18.1	20.0
Continuous Torque 80°C Rise ^{1,2,3}	T _c	lb-ft (N-m)	33.0 (44.7)	66.5 (90.1)	95.0 (129)
Cont. Line Current	I _c	amps RMS	11.4	13.7	15.6
Peak Torque	T _p	lb-ft (N-m)	88.2 (120)	170 (231)	234 (317)
Peak Line Current	I _p	amps RMS	40.0	48.0	48.0
Maximum Speed	N max	RPM	600	450	350
Weight	W _t	lb (kg)	61.0 (27.7)	91.0 (41.3)	120 (54.4)
Rotor Inertia	J _m	lb-ft-sec ² (kg-m ²)	0.021 (0.028)	0.035 (0.047)	0.049 (0.066)

CARTRIDGE DDR™ PERFORMANCE DATA

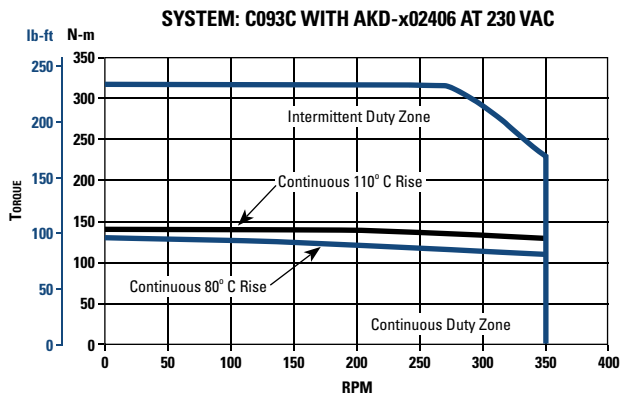
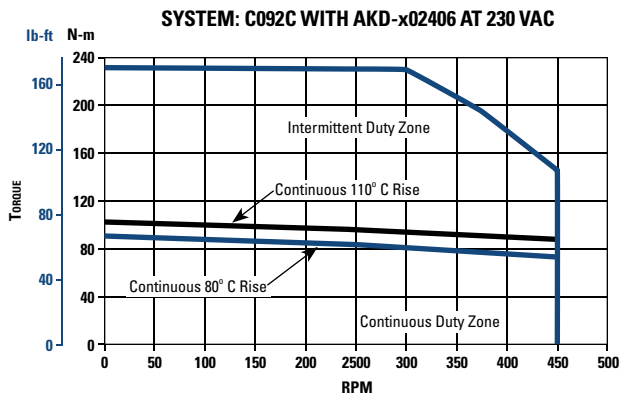
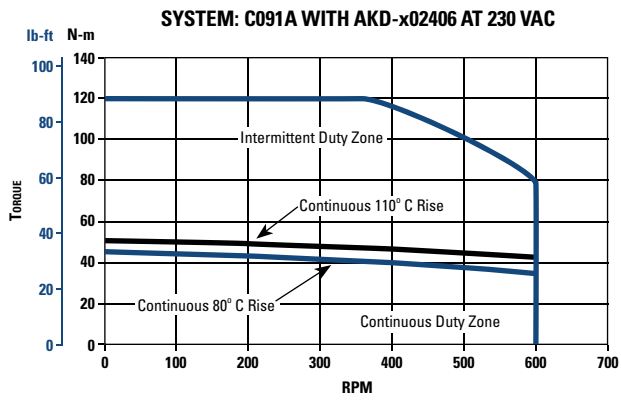

- Notes:
- At 40°C ambient.
 - Increase T_c by 1.06 times for 25°C ambient.
 - Temperature rise assumes a 16 x 16 x 0.75 inch aluminum mounting plate or equivalent.

*Complete CDDR series model nomenclature can be found on page 38.

Cartridge DDR™ Performance Data

CH09xA/C

System Performance at 400 /480 VAC CH09xA/C Cartridge DDR™ Motor with AKD® Drive Amplifier

System Performance	Symbol	Units	CH091A	CH092C	CH093C
Continuous Torque 110°C Rise ^{1,2,3}	T _c	lb-ft (N-m)	37.0 (50.2)	74.9 (102)	103 (139)
Cont. Line Current	I _c	amps RMS	12.8	18.1	20.0
Continuous Torque 80°C Rise ^{1,2,3}	T _c	lb-ft (N-m)	33.0 (44.7)	66.5 (90.1)	95.0 (129)
Cont. Line Current	I _c	amps RMS	11.4	13.7	15.6
Peak Torque	T _p	lb-ft (N-m)	88.2 (120)	170 (231)	228 (309)
Peak Line Current	I _p	amps RMS	40.0	48.0	48.0
Maximum Speed (400V) Maximum Speed (480V)	N max	RPM	1200 1500	800 1000	700 800
Weight	Wt	lb (kg)	61.0 (27.7)	91.0 (41.3)	120 (54.4)
Rotor Inertia	J _m	lb-ft-sec ² (kg-m ²)	0.021 (0.028)	0.035 (0.047)	0.049 (0.066)

CARTRIDGE DDR™ PERFORMANCE DATA

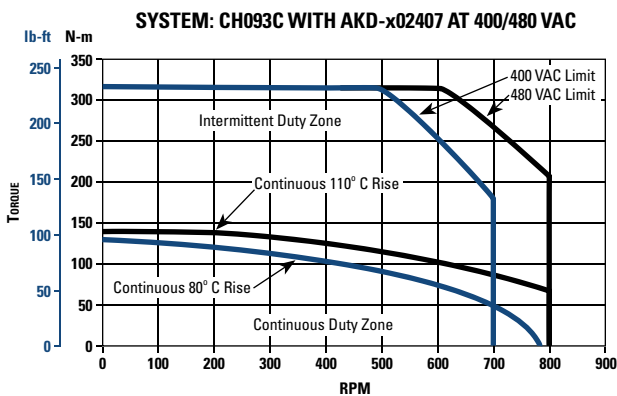
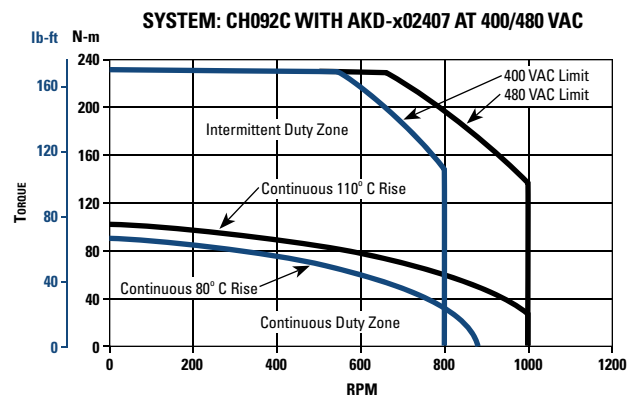
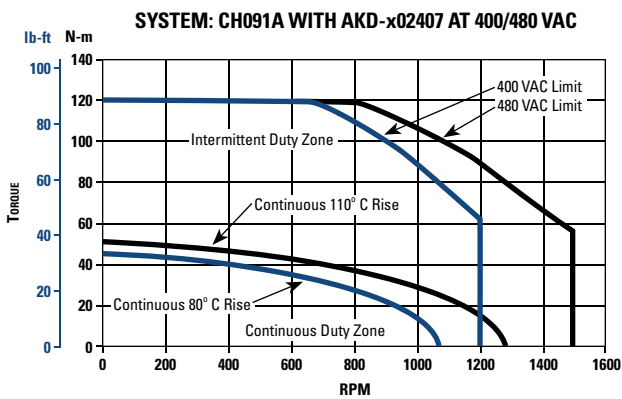

Notes:

1. At 40°C ambient.
2. Increase T_c by 1.06 times for 25°C ambient.
3. Temperature rise assumes a 16 x 16 x 0.75 inch aluminum mounting plate or equivalent.

C13xC

C 09 1 A - 11 - 1105 *

Motor Series | Frame Size | Stack Length | Winding | Connector | Mounting | Shaft | Feedback | Bearing | Seal

System Performance at 230 VAC C13xC Cartridge DDR™ Motor with AKD® Drive Amplifier

System Performance	Symbol	Units	C131C	C132C	C133C
Continuous Torque 110°C Rise ^{1,2,3}	Tc	lb-ft (N-m)	139 (189)	267 (362)	368 (499)
Cont. Line Current	lc	amps RMS	18.8	16.9	20.0
Continuous Torque 80°C Rise ^{1,2,3}	Tc	lb-ft (N-m)	123 (167)	236 (321)	330 (448)
Cont. Line Current	lc	amps RMS	16.6	15.0	17.9
Peak Torque	Tp	lb-ft (N-m)	291 (395)	603 (818)	791 (1070)
Peak Line Current	lp	amps RMS	48.0	48.0	48.0
Maximum Speed	N max	RPM	250	120	100
Weight	Wt	lb (kg)	140 (63.5)	223 (101)	292 (132)
Rotor Inertia	Jm	lb-ft-sec ² (kg-m ²)	0.091 (0.124)	0.166 (0.225)	0.223 (0.302)

CARRIAGE DDR™ PERFORMANCE DATA

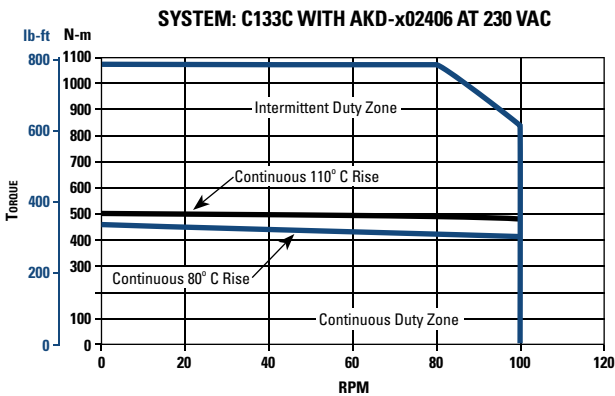
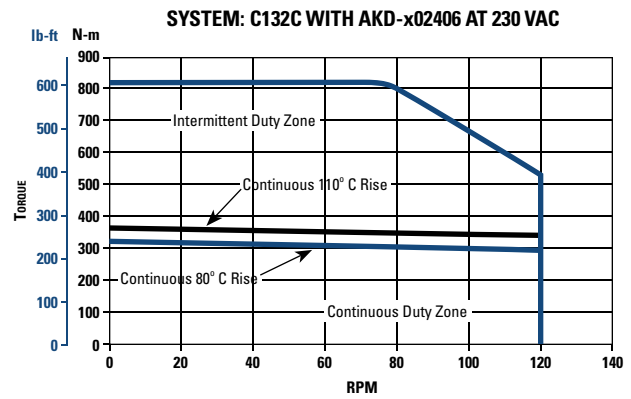
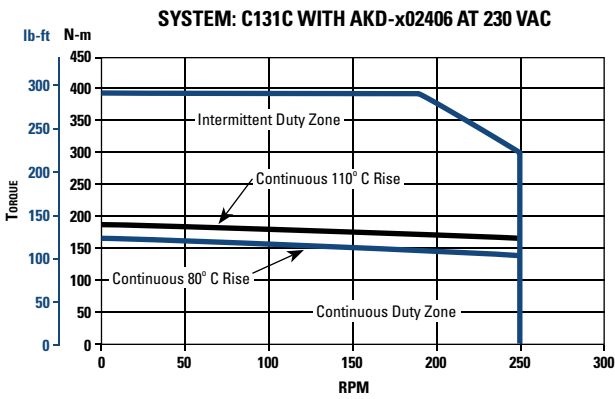

- Notes:
- At 40°C ambient.
 - Increase Tc by 1.06 times for 25°C ambient.
 - Temperature rise assumes a 20 x 20 x 0.75 inch aluminum mounting plate or equivalent.

*Complete CDDR series model nomenclature can be found on page 38.

Cartridge DDR™ Performance Data

CH13xC

System Performance at 400 /480 VAC CH13xC Cartridge DDR™ Motor with AKD® Drive Amplifier

System Performance	Symbol	Units	CH131C	CH132C	CH133C
Continuous Torque 110°C Rise ^{1,2,3}	Tc	lb-ft (N-m)	139 (189)	267 (362)	368 (499)
Cont. Line Current	lc	amps RMS	18.8	16.9	20.0
Continuous Torque 80°C Rise ^{1,2,3}	Tc	lb-ft (N-m)	123 (167)	236 (321)	330 (448)
Cont. Line Current	lc	amps RMS	16.6	15.0	17.9
Peak Torque	Tp	lb-ft (N-m)	291 (395)	603 (818)	791 (1070)
Peak Line Current	lp	amps RMS	48.0	48.0	48.0
Maximum Speed (400V) Maximum Speed (480V)	N max	RPM	500 600	250 300	200 250
Weight	Wt	lb (kg)	140 (63.5)	223 (101)	292 (132)
Rotor Inertia	Jm	lb-ft-sec ² (kg-m ²)	0.091 (0.124)	0.166 (0.225)	0.223 (0.302)

CARTRIDGE DDR™ PERFORMANCE DATA

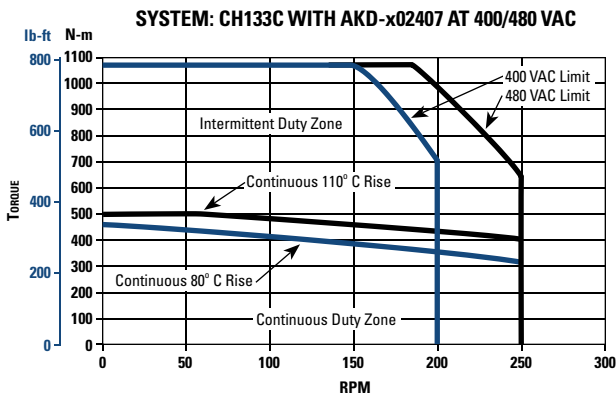
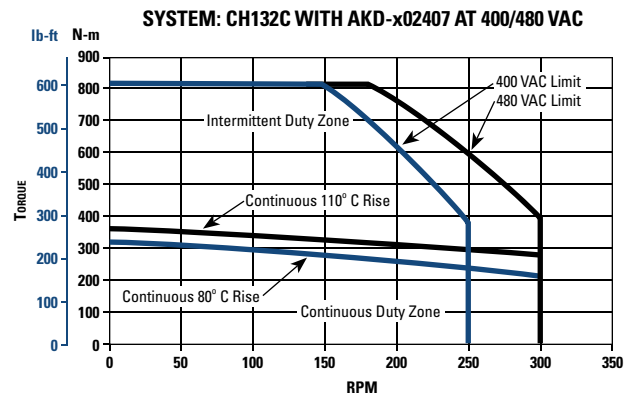
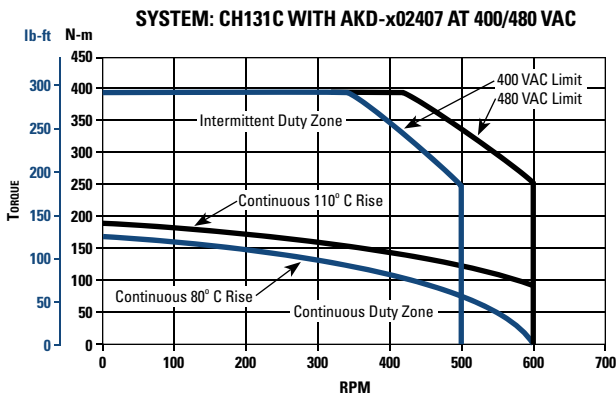

Notes:

1. At 40°C ambient.
2. Increase Tc by 1.06 times for 25°C ambient.
3. Temperature rise assumes a 20 x 20 x 0.75 inch aluminum mounting plate or equivalent.

C13xB

System Performance at 230 VAC C13xB Cartridge DDR™ Motor (High-Speed Winding) with AKD® Drive Amplifier

System Performance	Symbol	Units	C131B	C132B	C133B
Continuous Torque 110°C Rise ^{1,2,3}	Tc	lb-ft (N-m)	140 (190)	266 (361)	376 (510)
Cont. Line Current	lc	amps RMS	29.2	29.6	32.7
Continuous Torque 80°C Rise ^{1,2,3}	Tc	lb-ft (N-m)	124 (168)	236 (320)	333 (451)
Cont. Line Current	lc	amps RMS	25.9	26.3	29.0
Peak Torque	Tp	lb-ft (N-m)	292 (396)	560 (759)	749 (1016)
Peak Line Current	lp	amps RMS	80.0	80.0	96.0
Maximum Speed	N max	RPM	450	225	175
Weight	Wt	lb (kg)	140 (63.5)	223 (101)	292 (132)
Rotor Inertia	Jm	lb-ft-sec ² (kg-m ²)	0.091 (0.124)	0.166 (0.225)	0.223 (0.302)

CARRIAGE DDR™ PERFORMANCE DATA

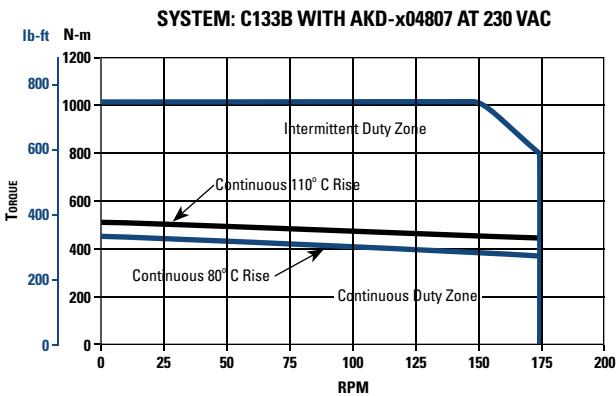
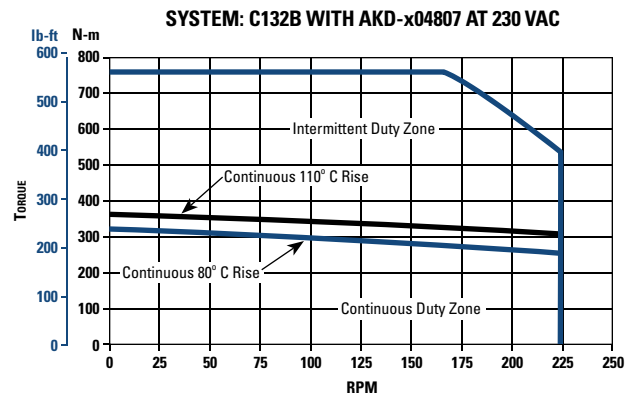
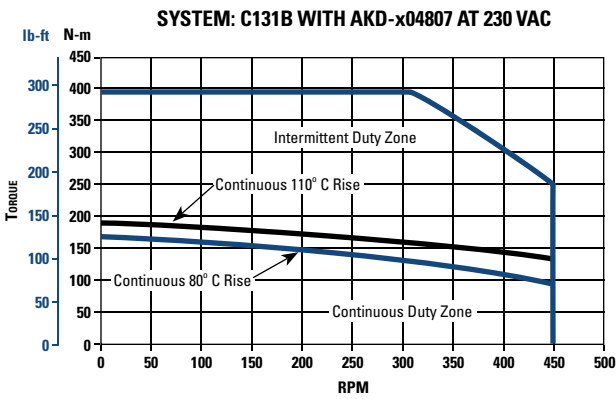

- Notes:
- At 40°C ambient.
 - Increase Tc by 1.06 times for 25°C ambient.
 - Temperature rise assumes a 20 x 20 x 0.75 inch aluminum mounting plate or equivalent.

*Complete CDDR series model nomenclature can be found on page 38.

Cartridge DDR™ Performance Data

CH13xB

System Performance at 400 /480 VAC CH13xB Cartridge DDR™ Motor (High-Speed Winding) with AKD® Drive Amplifier

System Performance	Symbol	Units	CH131B	CH132B	CH133B
Continuous Torque 110°C Rise ^{1,2,3}	T _c	lb-ft (N-m)	140 (190)	266 (361)	372 (510)
Cont. Line Current	I _c	amps RMS	29.2	29.6	32.7
Continuous Torque 80°C Rise ^{1,2,3}	T _c	lb-ft (N-m)	124 (168)	236 (320)	333 (451)
Cont. Line Current	I _c	amps RMS	25.9	26.3	29.0
Peak Torque	T _p	lb-ft (N-m)	292 (396)	560 (759)	749 (1016)
Peak Line Current	I _p	amps RMS	80.0	80.0	96.0
Maximum Speed (400V) Maximum Speed (480V)	N max	RPM	800 1000	400 500	350 400
Weight	Wt	lb (kg)	140 (63.5)	223 (101)	292 (132)
Rotor Inertia	J _m	lb-ft-sec ² (kg-m ²)	0.091 (0.124)	0.166 (0.225)	0.223 (0.302)

CARTRIDGE DDR™ PERFORMANCE DATA

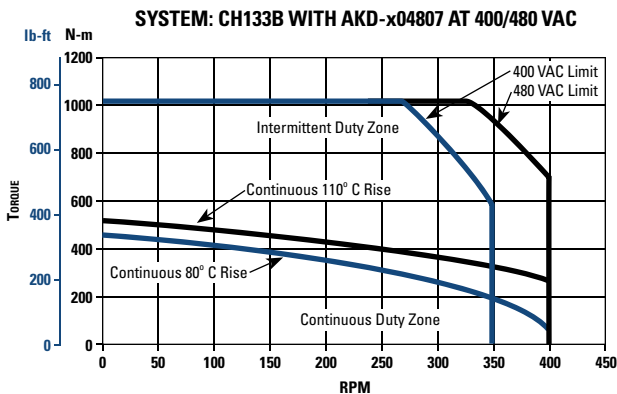
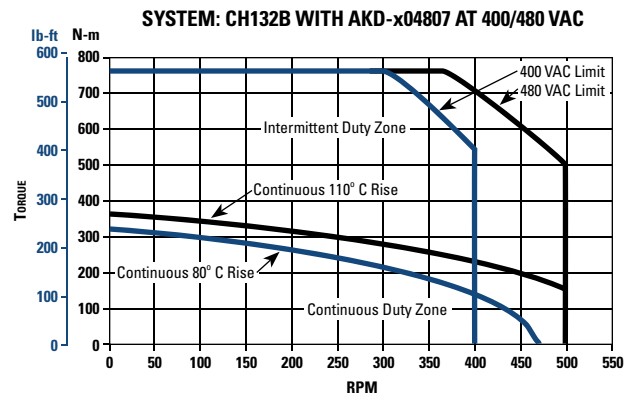
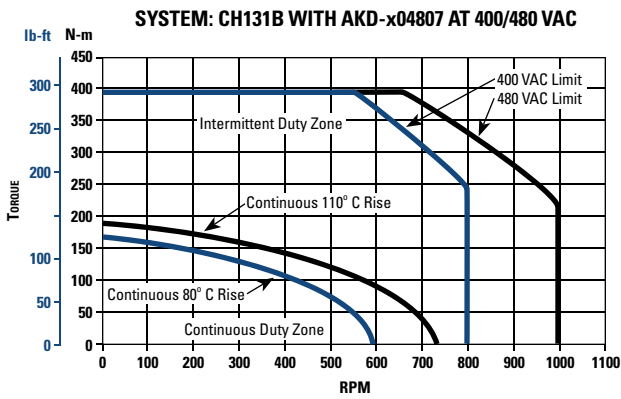

Notes:

1. At 40°C ambient.
2. Increase T_c by 1.06 times for 25°C ambient.
3. Temperature rise assumes a 20 x 20 x 0.75 inch aluminum mounting plate or equivalent.

Notes

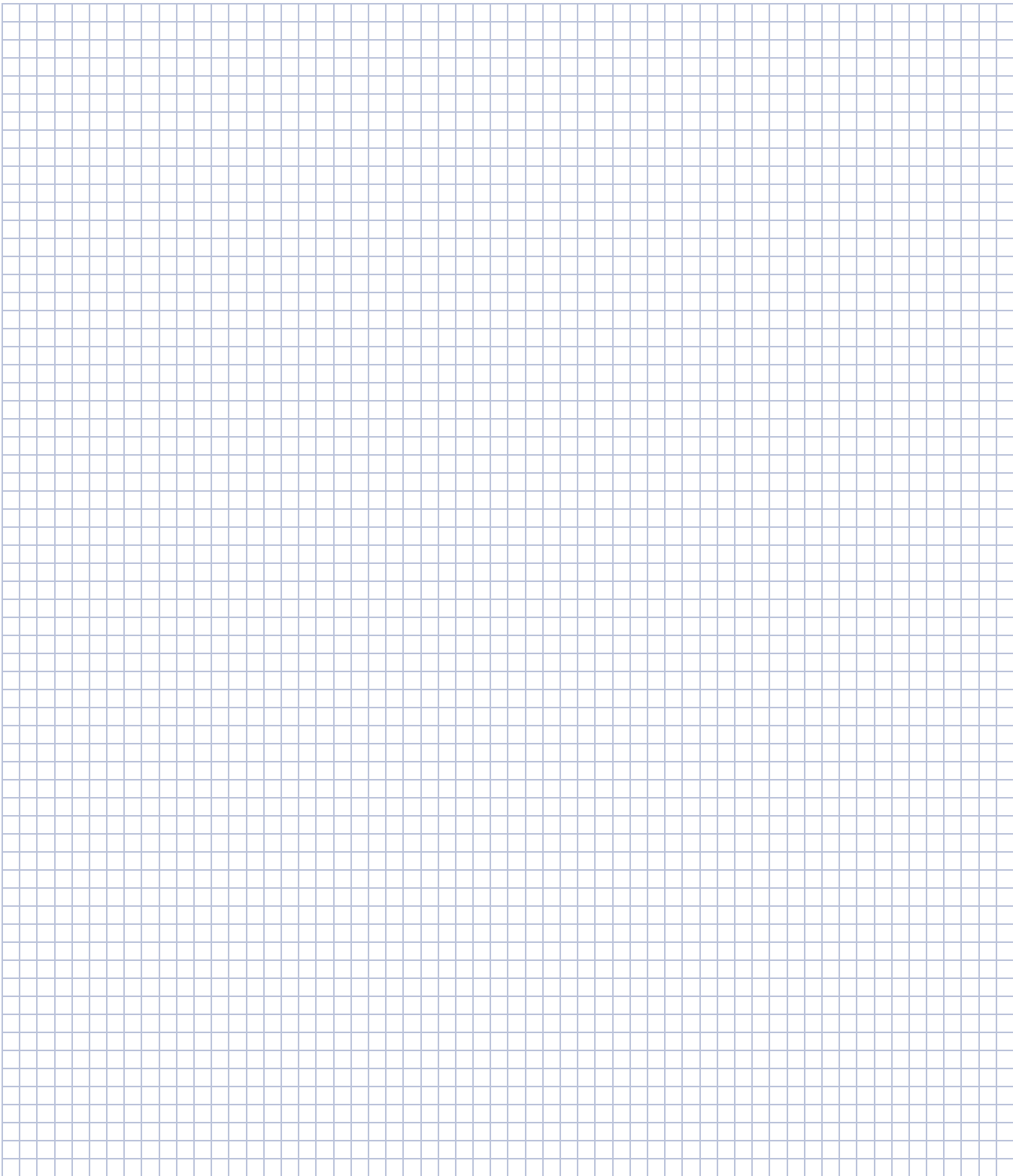

Cartridge DDR™ Outline Drawings

C(H)04x

CARTRIDGE DDR™ OUTLINE DRAWINGS

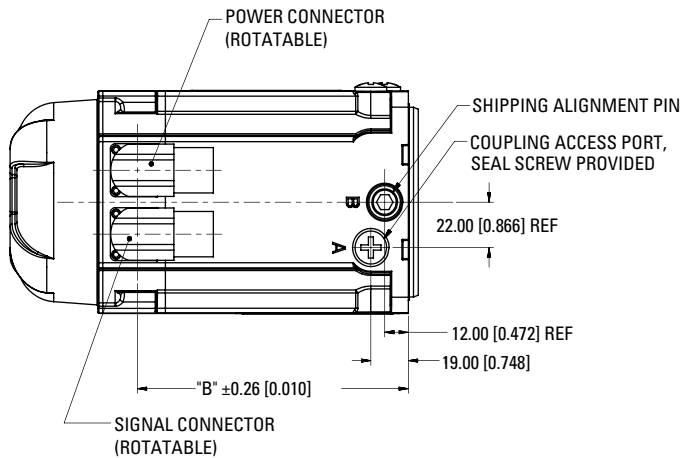
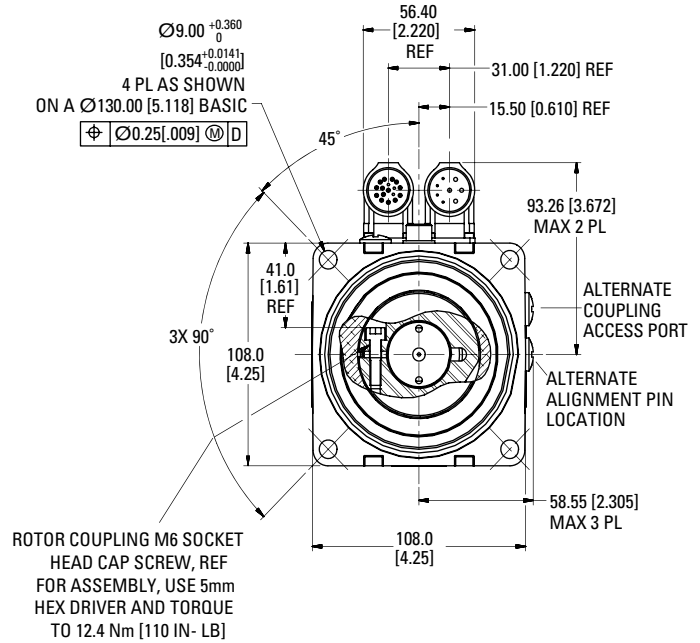
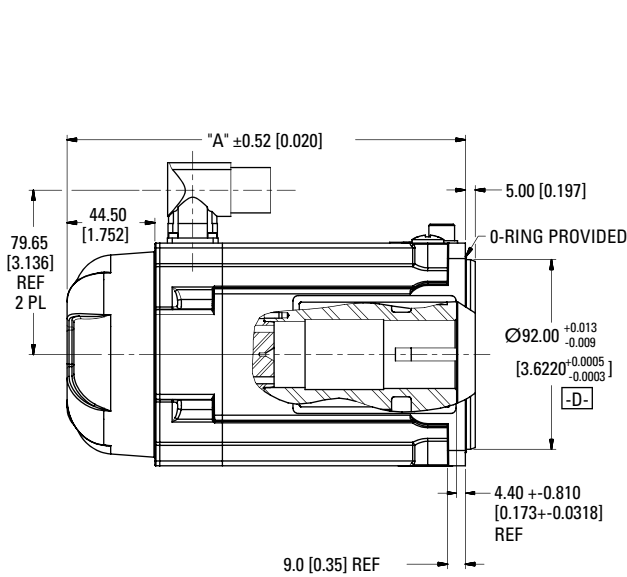

DIMENSION	C041	C042	C043	C044
"A"	171 (6.72)	202 (7.94)	233 (9.16)	264 (10.4)
"B"	107 (4.22)	138 (5.44)	169 (6.66)	200 (7.88)

Dimensions in mm [inches]

For machine interface detail, see page 36

C(H)05x

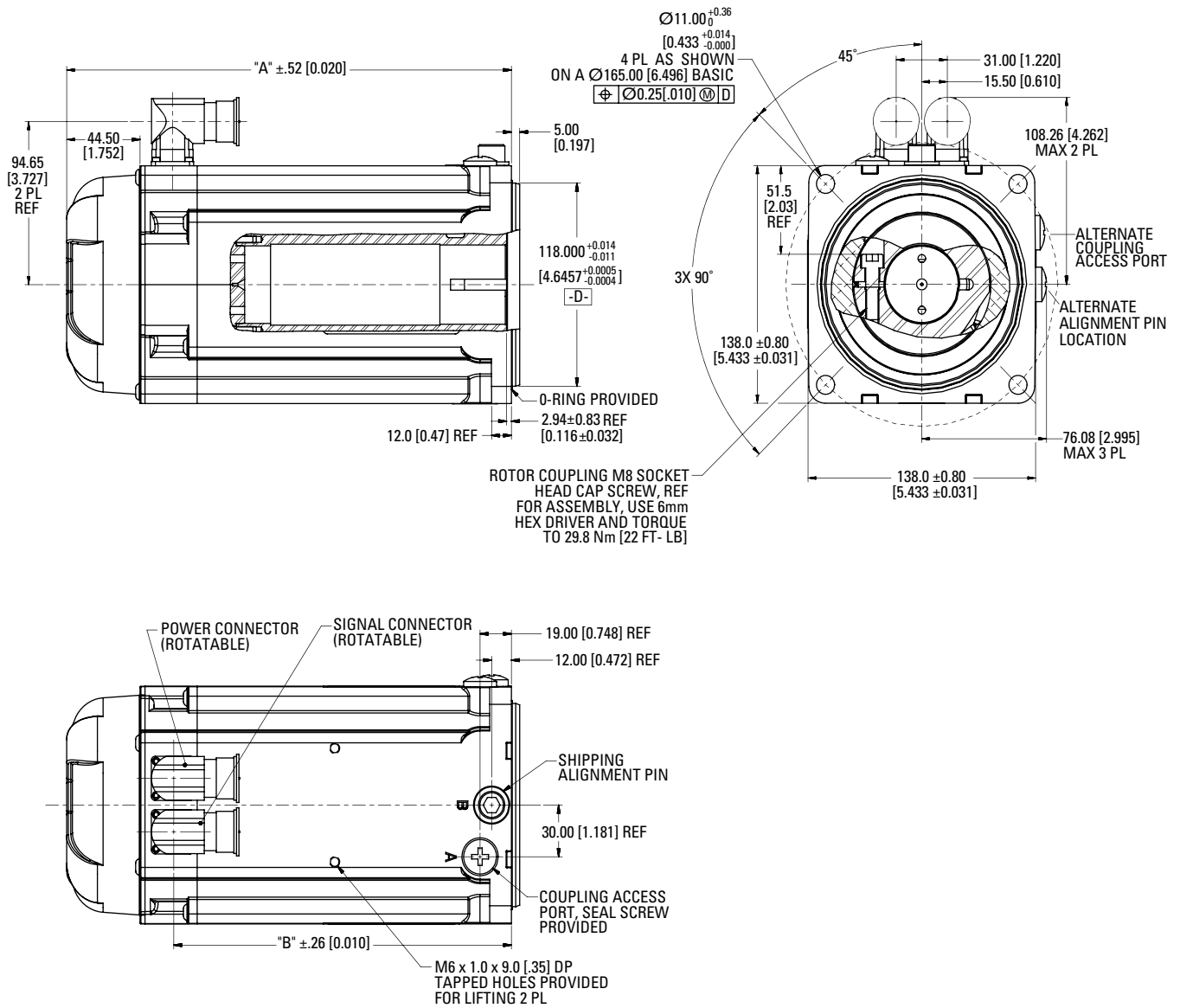

CARTRIDGE DR™ OUTLINE DRAWINGS

DIMENSION	C051	C052	C053	C054
"A"	195 (7.67)	220 (8.65)	245 (9.63)	270 (10.6)
"B"	131 (5.14)	156 (6.12)	181 (7.11)	206 (8.09)

Dimensions in mm [inches]

For machine interface detail, see page 36

Cartridge DDR™ Outline Drawings

C(H)06x

CARTRIDGE DDR™ OUTLINE DRAWINGS

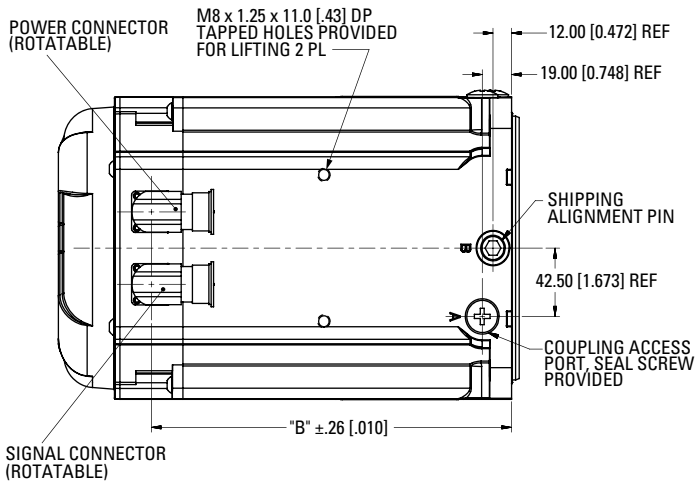
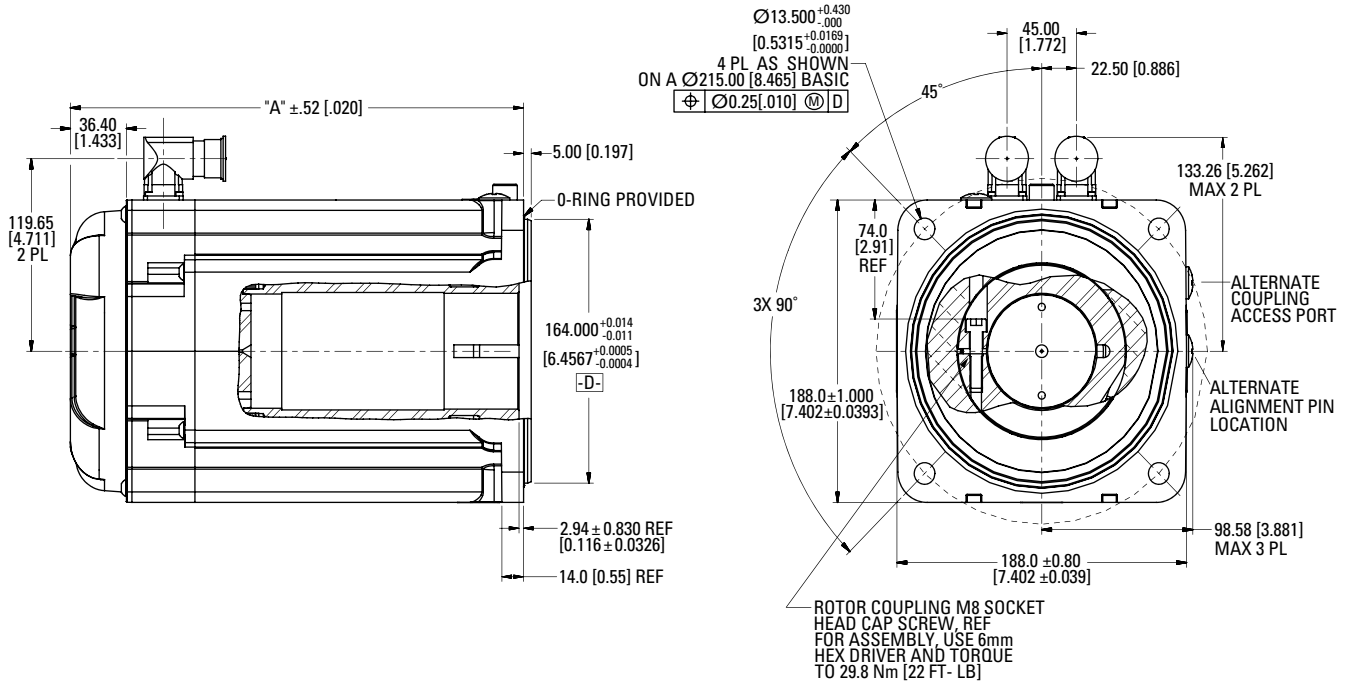

Dimension	C061	C062	C063
"A"	226 [8.90]	260 [10.2]	294 [11.6]
"B"	166 [6.52]	200 [7.86]	234 [9.20]

Dimensions in mm [inches]

For machine interface detail, see page 36

C(H)09x without Through Bore

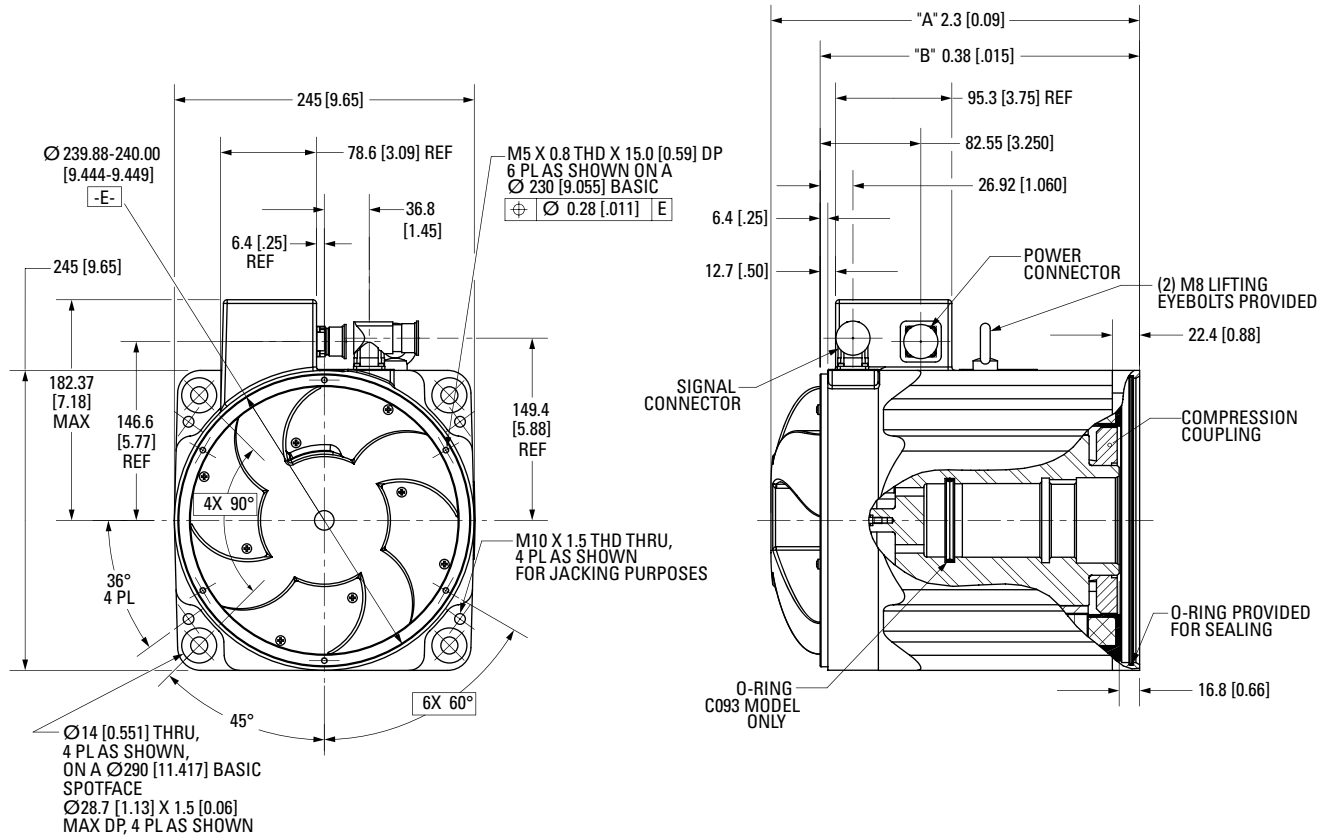

Rear Connector Option

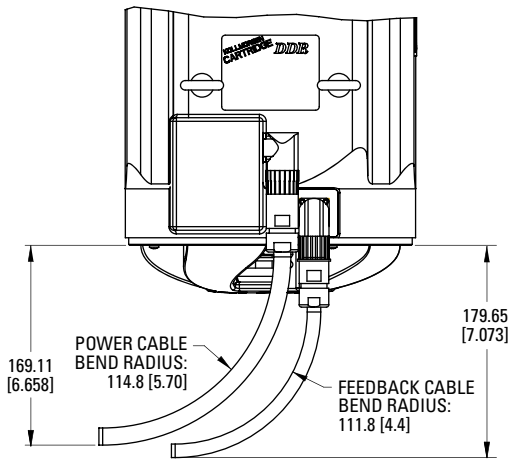

Side Connector Option

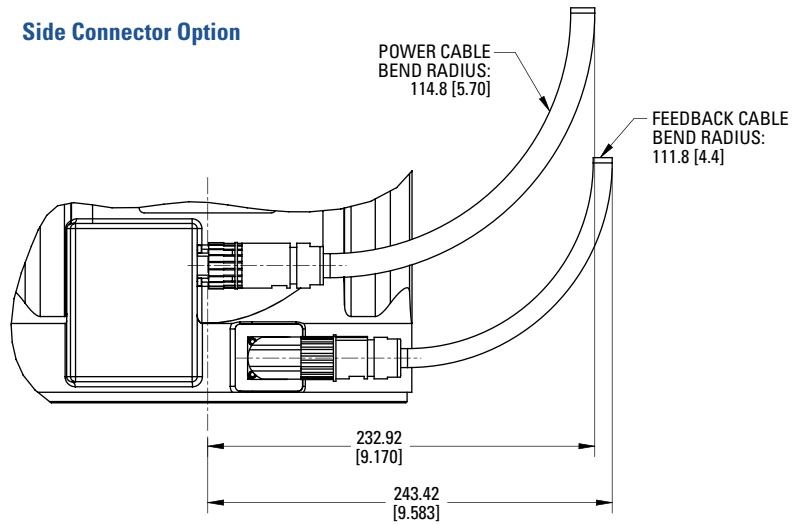

Dimension	C(H)091	C(H)092	C(H)093
"A"	204 [7.99]	253 [9.94]	302 [11.9]
"B"	163 [6.40]	212 [8.36]	262 [10.3]

Dimensions in mm [inches]

For machine interface detail, see page 37

Cartridge DDR™ Outline Drawings

C(H)09X with Through Bore

CARTRIDGE DDR™ OUTLINE DRAWINGS

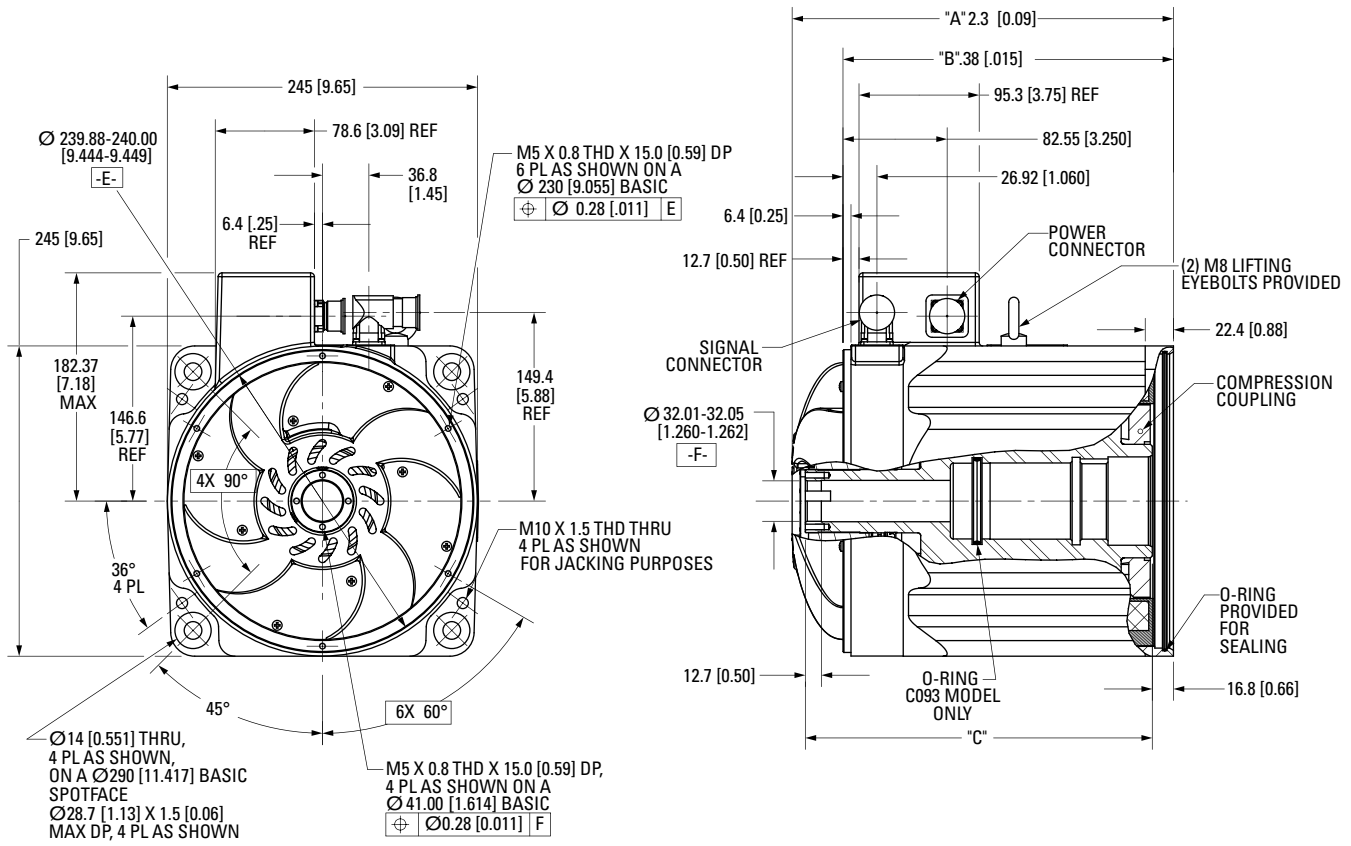

Rear Connector Option

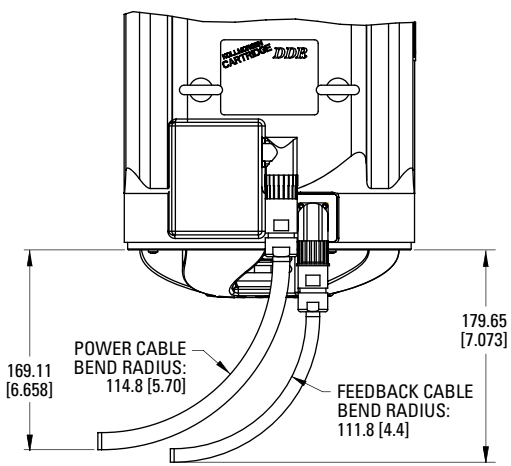

Side Connector Option

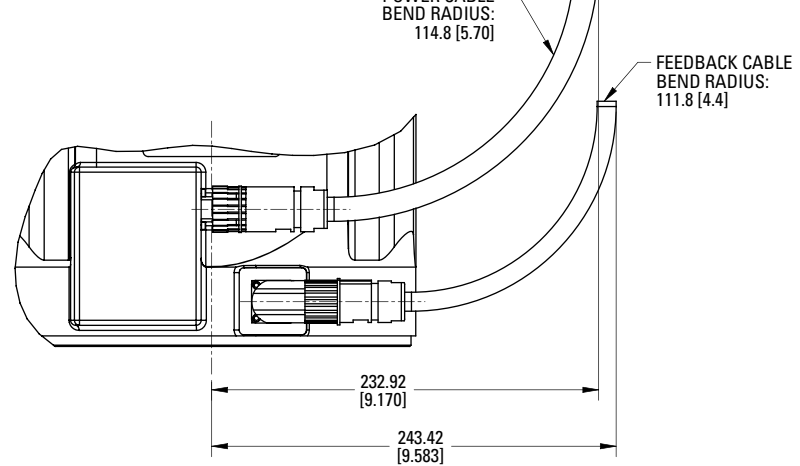

DIMENSION	C(H)091	C(H)092	C(H)093
"A"	204 [7.99]	253 [9.94]	302 [11.9]
"B"	163 [6.40]	212 [8.36]	262 [10.3]
"C"	176 [6.92]	225 [8.87]	275 [10.8]

Dimensions in mm [inches]

For machine interface detail, see page 37

C(H)13X without Through Bore

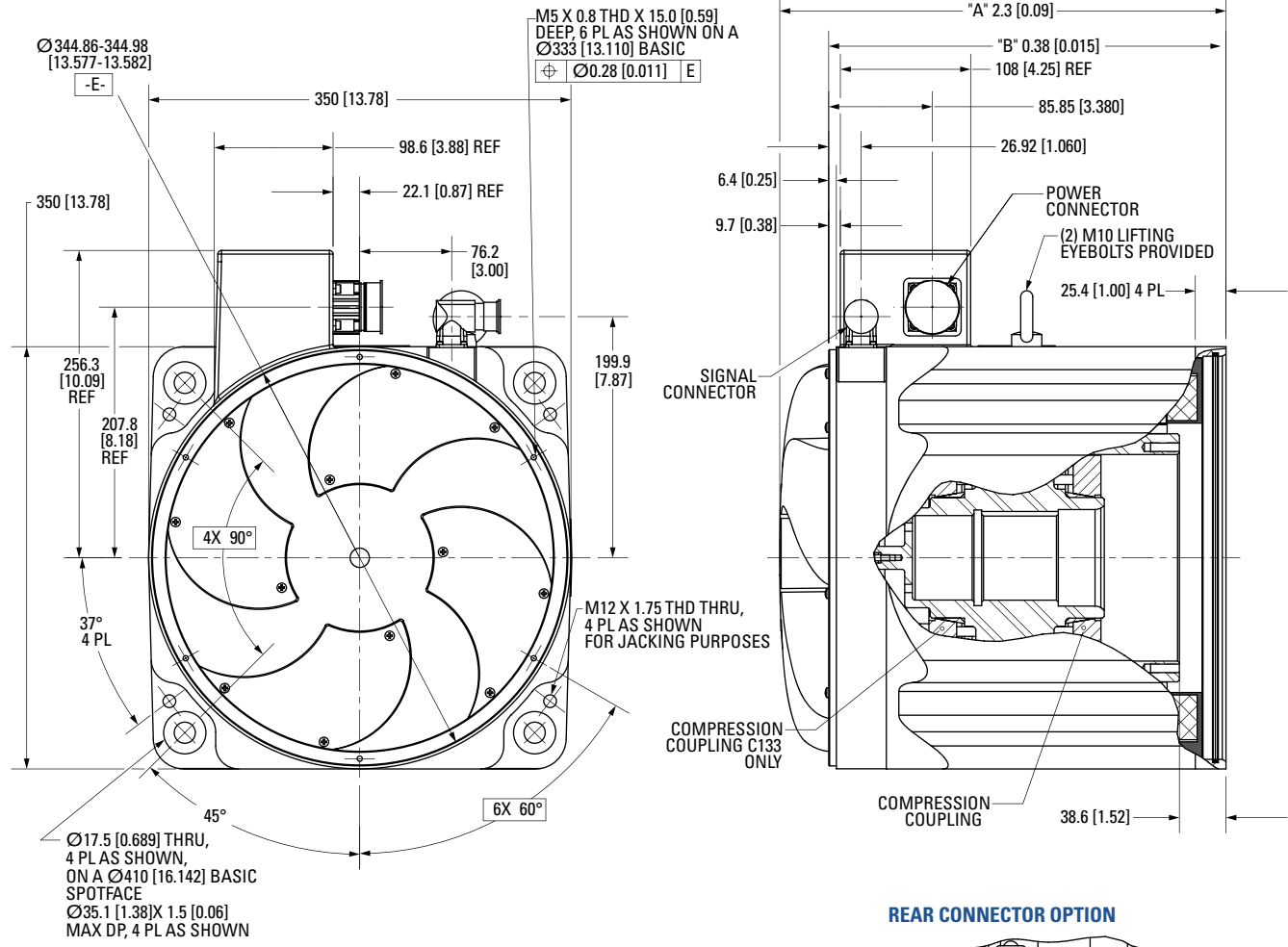

SIDE CONNECTOR OPTION

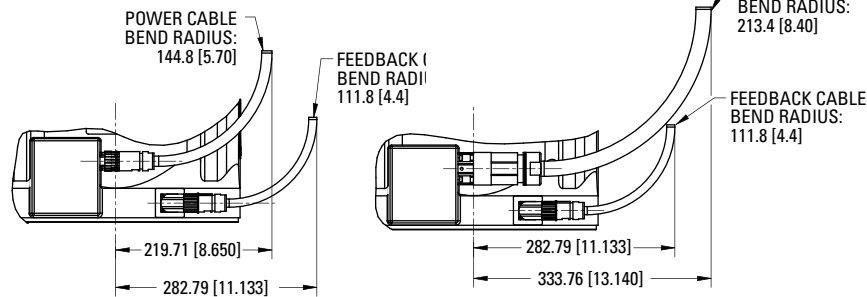

C13X LOW CURRENT

C13X HIGH CURRENT

DIMENSION	C(H)131	C(H)132	C(H)133
"A"	231 [9.11]	301 [11.8]	370 [14.6]
"B"	191 [7.52]	260 [10.2]	329 [13.0]

REAR CONNECTOR OPTION

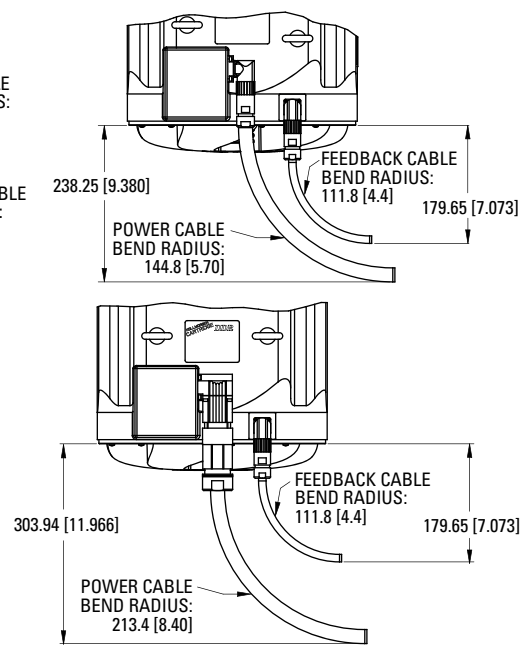

Dimensions in mm [inches]

For machine interface detail, see page 37

Cartridge DDR™ Outline Drawings

C(H)13x with Through Bore

CARTRIDGE DDR™ OUTLINE DRAWINGS

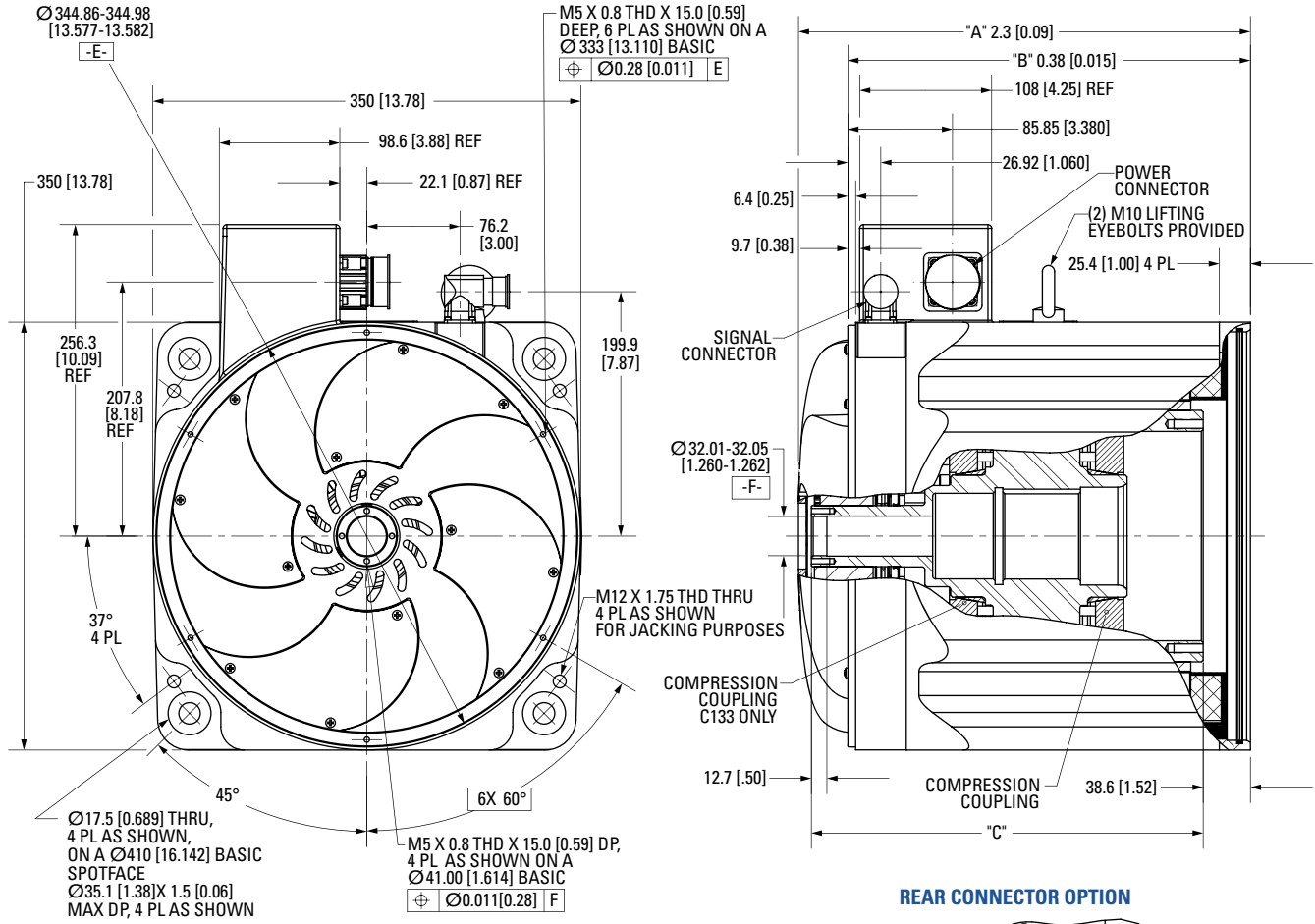

REAR CONNECTOR OPTION

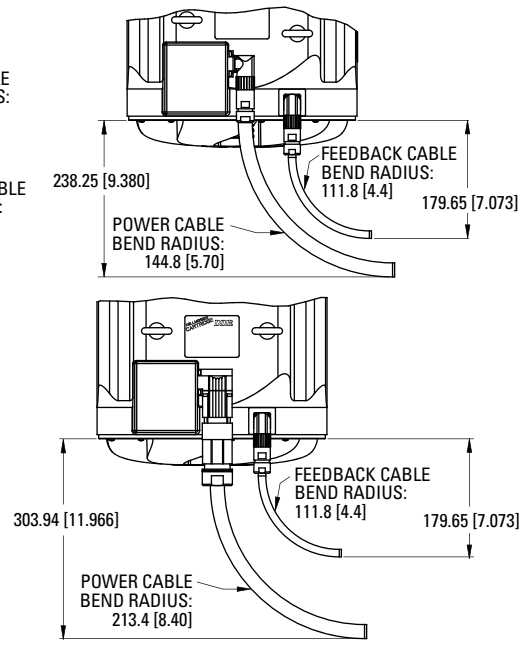

SIDE CONNECTOR OPTION

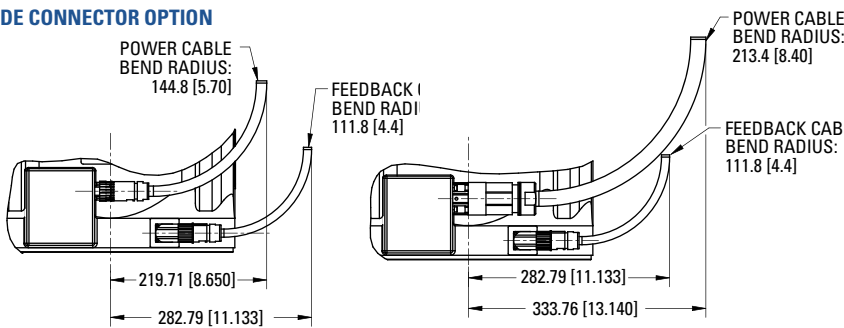

C13X LOW CURRENT

C13X HIGH CURRENT

DIMENSION	C(H)131	C(H)132	C(H)133
"A"	231 [9.11]	301 [11.8]	370 [14.6]
"B"	191 [7.52]	260 [10.2]	329 [13.0]
"C"	182 [7.18]	251 [9.90]	320 [12.6]

For machine interface detail, see page 37

Dimensions in mm [inches]

Notes

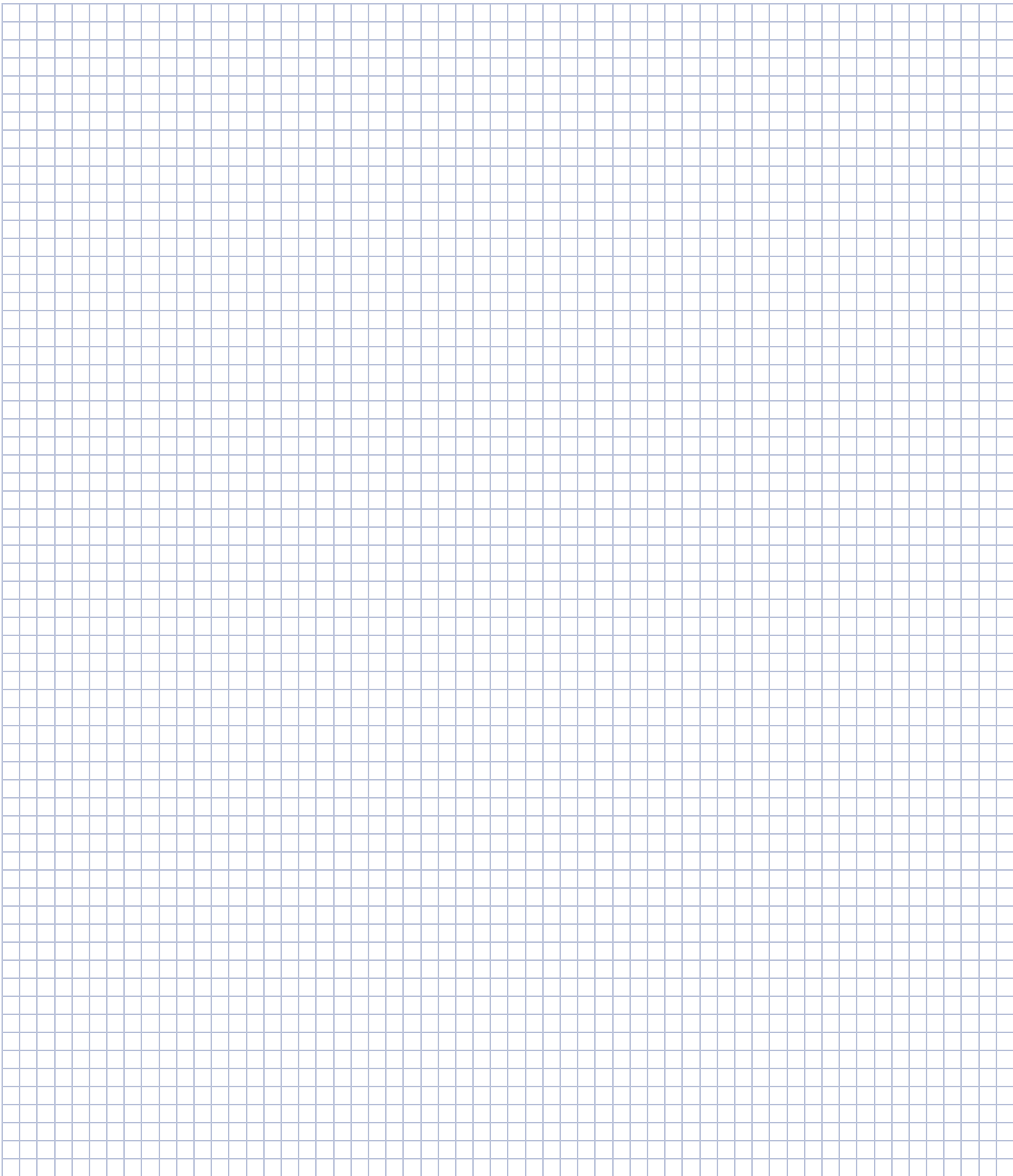

Cartridge DDR™ Mounting Requirements

Machine Mounting Requirements for C(H)04x, C(H)05x and C(H)06x

This drawing details the machine interface configuration for mounting the C(H)04, C(H)05 and C(H)06 Cartridge DDR motors. It is important to maintain specified tolerance, concentricity and run out to ensure proper operation and longevity of the Cartridge DDR motor.

Axial Shaft Movement

During operation, the shaft which the Cartridge DDR motor is mounted to shall not move axially more than +/- 0.13 mm (0.005 inch).

Shaft Material

The shaft material can be steel or stainless steel.

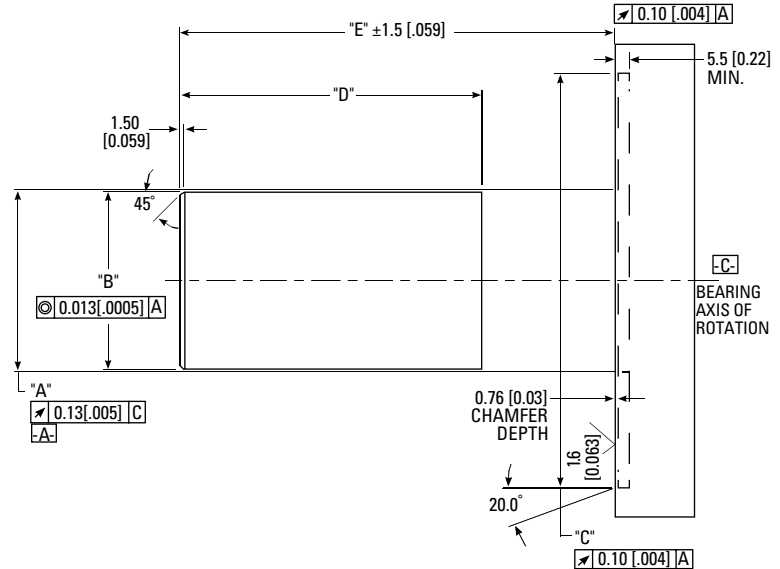

Machine Dimensions

Model	Dimensions									
	A		B		C		D		E	
	Min.	Max.	Min.	Max.	Min.	Max.	Min.	Max.	Min.	Max.
C(H)041	32.985	33.000	31.985	32.000	92.040	92.090	16.6	17.4	59.8	62.8
	[1.2987	- 1.2992]	[1.2593	- 1.2598]	[3.6237	- 3.6255]	[0.655	- 0.685]	[2.351	- 2.469]
C(H)042	32.985	33.000	31.985	32.000	92.040	92.090	47.6	48.4	90.8	93.8
	[1.2987	- 1.2992]	[1.2593	- 1.2598]	[3.6237	- 3.6255]	[1.875	- 1.905]	[3.571	- 3.689]
C(H)043	32.985	33.000	31.985	32.000	92.040	92.090	78.6	79.4	121.8	124.8
	[1.2987	- 1.2992]	[1.2593	- 1.2598]	[3.6237	- 3.6255]	[3.095	- 3.125]	[4.791	- 4.909]
C(H)044	32.985	33.000	31.985	32.000	92.040	92.090	109.6	110.4	152.8	155.8
	[1.2987	- 1.2992]	[1.2593	- 1.2598]	[3.6237	- 3.6255]	[4.315	- 4.345]	[6.011	- 6.129]
C(H)051	45.985	46.000	44.985	45.000	118.040	118.090	34.6	35.4	80.5	83.5
	[1.8105	- 1.8110]	[1.7712	- 1.7717]	[4.6473	- 4.6492]	[1.365	- 1.395]	[3.171	- 3.289]
C(H)052	45.985	46.000	44.985	45.000	118.040	118.090	59.6	60.4	105.5	108.5
	[1.8105	- 1.8110]	[1.7712	- 1.7717]	[4.6473	- 4.6492]	[2.345	- 2.375]	[4.151	- 4.269]
C(H)053	45.985	46.000	44.985	45.000	118.040	118.090	84.6	85.4	130.5	133.5
	[1.8105	- 1.8110]	[1.7712	- 1.7717]	[4.6473	- 4.6492]	[3.335	- 3.365]	[5.141	- 5.259]
C(H)054	45.985	46.000	44.985	45.000	118.040	118.090	109.6	110.4	155.5	158.5
	[1.8105	- 1.8110]	[1.7712	- 1.7717]	[4.6473	- 4.6492]	[4.315	- 4.345]	[6.121	- 6.239]
C(H)061	71.985	72.000	70.985	71.000	164.040	164.090	48.6	49.4	102.5	105.5
	[2.8341	- 2.8346]	[2.7948	- 2.7953]	[6.4583	- 6.4602]	[1.915	- 1.945]	[4.031	- 4.149]
C(H)062	71.985	72.000	70.985	71.000	164.040	164.090	82.6	83.4	136.5	139.5
	[2.8341	- 2.8346]	[2.7948	- 2.7953]	[6.4583	- 6.4602]	[3.255	- 3.285]	[5.371	- 5.489]
C(H)063	71.985	72.000	70.985	71.000	164.040	164.090	116.6	117.4	170.5	173.5
	[2.8341	- 2.8346]	[2.7948	- 2.7953]	[6.4583	- 6.4602]	[4.595	- 4.625]	[6.711	- 6.829]

Dimensions are in millimeters [inches]

Machine Mounting Requirements for C(H)09x and C(H)13x

This drawing details the machine interface configuration for mounting the C(H)09 and C(H)13 Cartridge DDR motors. It is important to maintain specified tolerance, concentricity, and run out to ensure proper operation and longevity of the Cartridge DDR motor.

Axial Shaft Movement

Note there is a static and dynamic call out for axial length. The static tolerance is the allowable variance of the shaft before the motor is mounted. The dynamic tolerance is the allowable movement of the shaft after the motor is mounted and during operation.

Shaft Material

The shaft material must have a minimum yield strength of 55,000 PSI. This suggests the material shall be cold rolled steel with a minimum 0.30% carbon content.

Shaft Key

The C09x and C13x Cartridge DDR motors are provided with a key. If the materials and dimensions on this page and the compression coupling torque procedure are strictly followed, then the key is not needed. The key is provided as a safety precaution to avoid severe damage to the Cartridge DDR motor and to the machine it is mounted to that can result if the compression coupling is not properly engaged during operation. No key is used on the C04x, C05x and C06x.

Heat Dissipation

The Cartridge DDR motor is a source of heat connected directly to the machine frame. For applications which are sensitive to heat generation, the continuous torque rating of the Cartridge DDR must be reduced. To facilitate heat sensitive applications, Cartridge DDR motors have dual continuous torque ratings, 110°C rise for maximum capacity and 80°C rise for de-rated capacity.

Dimensions are in millimeters [inches]

C(H)09x

Dimension	C(H)091	C(H)092	C(H)093
"A"	43.94 [1.730]	83.14 [3.470]	127.41 [4.910]
"B"	9.65 [0.38]	23.88 [0.94]	25.4 [1.00]
"C"	89.92 [3.540]	134.11 [5.280]	170.69 [6.720]

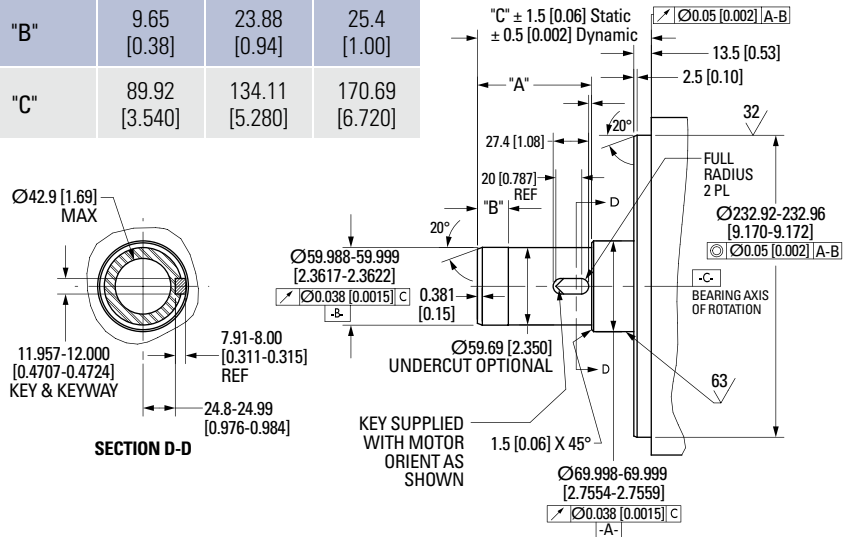

C(H)13x

Dimension	C(H)131	C(H)132	C(H)133
"A"	9.40 [0.37]	19.05 [0.75]	40.64 [1.6]
"B"	40.39 [1.590]	83.82 [3.300]	118.62 [4.670]
"C"	27.43 [1.08]	43.43 [1.71]	57.40 [2.26]
"D"	114.05 [4.490]	167.89 [6.610]	253.49 [9.980]

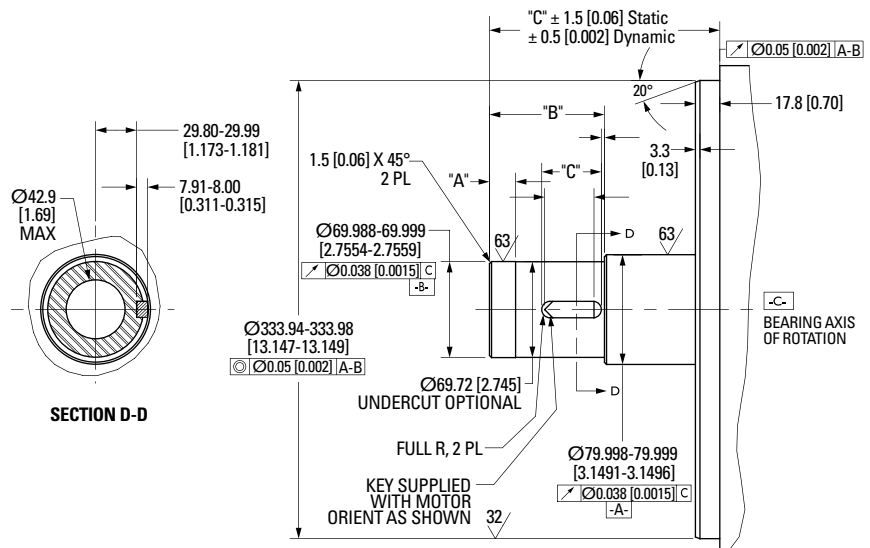

Model Nomenclature

Cartridge DDR Motor

C 09 1 A - 1 1 - 1 1 0 5 - xxx

Product Family

C = 230 Volt
CH = 400/480 Volt

Frame Size Field

04 = 4.25" Sq. Housing
05 = 5.43" Sq. Housing
06 = 7.40" Sq. Housing
09 = 9.68" Sq. Housing
13 = 13.78" Sq. Housing

Stack Length Field

1 = Short Stack
2 = Mid Stack
3 = Long Stack
4 = Extra Long Stack
(04 and 05 frame sizes only)

Winding Letter Field

A = Standard Winding
B = High-Speed Winding (C04x, C05x, C06x, C13x)
C = Standard Winding (C052, C062, C063, C092, C093, C13x)
D = High-Speed Winding (C052 only)

Mounting Option Field

1 = Std. Flange Mount

Connector Option Field

1 = Side Connector Option (09 and 13 frame sizes only)
2 = Rear Connector Option (09 and 13 frame sizes only)
3 = 90° Rotatable Connectors (04, 05 and 06 frame sizes only)

Sequential number for specials
(Unique description within a frame size)

Unit Seal Option Field

5 = Sealed
(Shaft Option "1" - IP64 Rating when customer seals interface side)
(Shaft Option "2" or "3" - IP65 Rating when customer seals interface side)

Bearing Option Field

0 = No Bearing Design
(Standard - Integral Shipping Clamp Provided)

Feedback Option Field

1 = EnDat single turn absolute sine encoder (2048 line)
3 = BiSS single turn absolute sine encoder (2048 line)
4 = BiSS multi-turn absolute sine encoder (2048 line)
5 = EnDat Multi-turn absolute sine encoder (2048 line)

Shaft Field

1 = Hollow with Compression Coupling and Key
(09 and 13 frame sizes only)
2 = Solid with Compression Coupling and Key
(09 and 13 frame sizes only)
3 = Solid with Split Ring Coupling and no Key
(04, 05, and 06 frame sizes only)

Note: Options shown in blue text are considered standard.

Notes

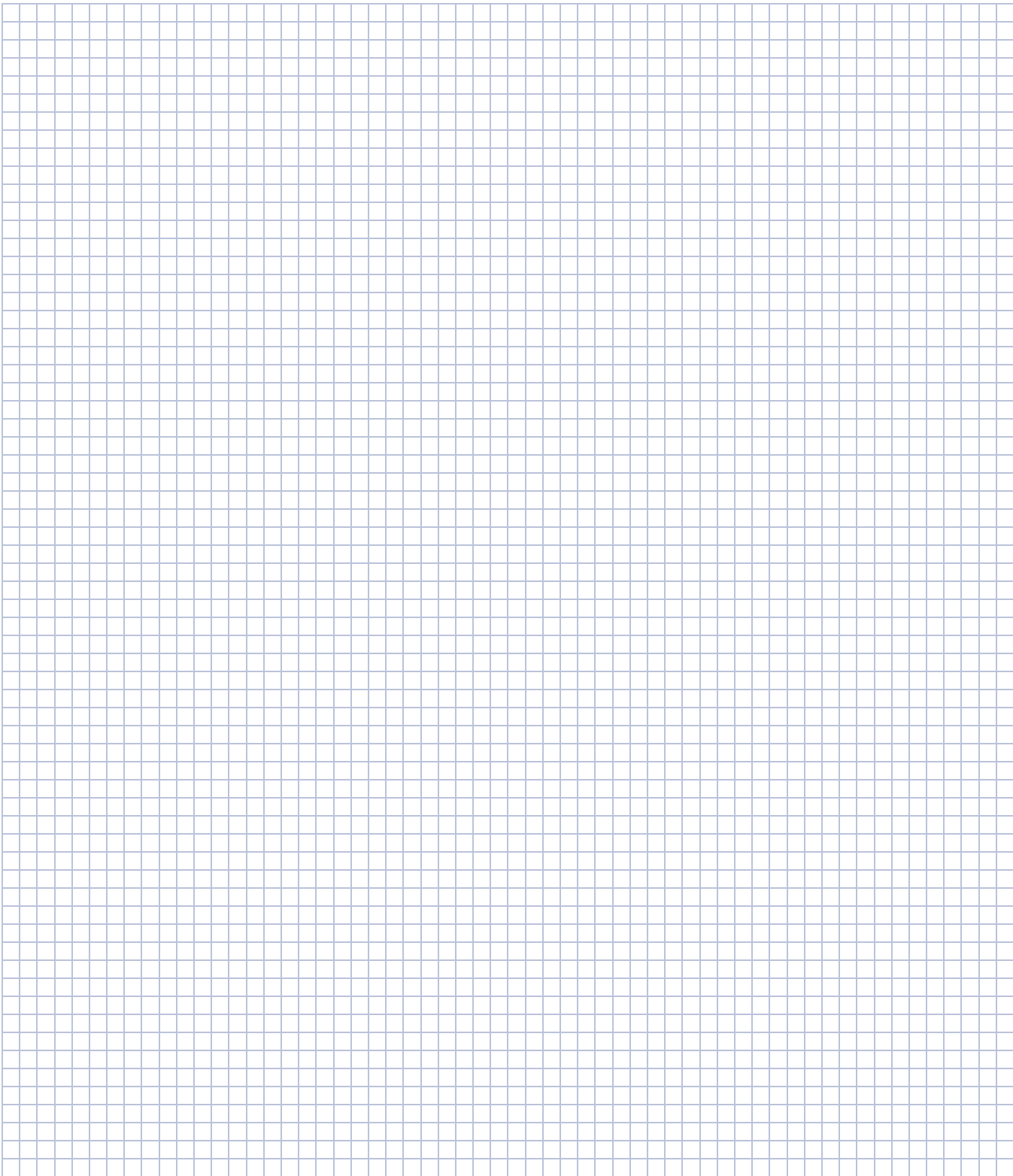

▶ AKD[®] Servo Drive

Our AKD series is a complete range of Ethernet-based servo drives that are fast, feature-rich, flexible and integrate quickly and easily into any application. AKD ensures plug-and-play commissioning for instant, seamless access to everything in your machine. And, no matter what your application demands, AKD offers industry-leading servo performance, communication options, and power levels, all in a smaller footprint.

This robust, technologically advanced family of drives delivers optimized performance when paired with our best-in-class components, producing higher quality results at greater speeds and more uptime. With Kollmorgen servo components, we can help you increase your machine's overall equipment effectiveness (OEE) by 50%.

The Benefits of AKD Servo Drive

- Optimized Performance in Seconds
 - Auto-tuning is one of the best and fastest in the industry
 - Automatically adjusts all gains, including observers
 - Immediate and adaptive response to dynamic loads
 - Precise control of all motor types
 - Compensation for stiff and compliant transmission and couplings
- Greater Throughput and Accuracy
 - Up to 27-bit-resolution feedback yields unmatched precision and excellent repeatability
 - Very fast settling times result from a powerful dual processor system that executes industry-leading and patent pending servo algorithms with high resolution
 - Advanced servo techniques such as high-order observer and bi-quad filters yield industry-leading machine performance
 - Highest bandwidth torque-and-velocity loops. Fastest digital current loop in the market
- Easy-to-use Graphical User Interface (GUI) for Faster Commissioning and Troubleshooting
 - Six-channel real-time software oscilloscope commissions and diagnoses quickly
 - Multi-function Bode Plot allows users to quickly evaluate performance
 - Auto-complete of programmable commands saves looking up parameter names
 - One-click capture and sharing of program plots and parameter settings allow you to send machine performance data instantly
 - Widest range of programming options in the industry
- Flexible and Scalable to Meet any Application
 - 3 to 48 Arms continuous current; 9 to 96 Arms peak
 - Very high power density enables an extremely small package
 - True plug-and-play with all standard Kollmorgen servo motors and actuators
 - Supports a variety of single and multi-turn feedback devices—Smart Feedback Device (SFD), EnDat2.2, 01, BiSS, analog Sine/Cos encoder, incremental encoder, HIPERFACE®, and resolver
 - Tightly integrated Ethernet motion buses without the need to add large hardware: EtherCAT®, SynqNet®, Modbus® TCP, EtherNet/IP™, PROFINET® RT, SERCOS® III, and CANopen®
 - Scalable programmability from base torque-and-velocity through multi-axis master

AKD[®] Servo Drive

The AKD servo drive delivers cutting-edge technology and performance with one of the most compact footprints in the industry. These feature-rich drives provide a solution for nearly any application, from basic torque-and-velocity applications, to indexing, to multi-axis programmable motion with embedded Kollmorgen Automation Suite™. The versatile AKD sets the standard for power density and performance.

AKD[®] SERVO DRIVE



AKMH[™] Hygienic Stainless Steel Motors

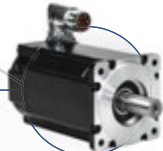

AKM[®] 2G Servo Motors



Frameless Brushless Direct Drive Motors



AKD[®]-N Decentralized Servo Drive



Cartridge DDR[®] Motors

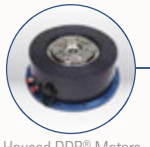

Housed DDR[®] Motors



Direct Drive Linear Motors



Linear Actuators

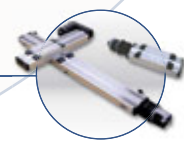

Multi-Axis Precision Tables



AKD[®] Servo Drive



Control of motors with AKD[®] PDMM programmable multi-axis master

Best-in-Class Components

AKD works seamlessly with Kollmorgen motors and actuators—well-known for quality, reliability, and performance.



Industry-leading power density



48A @ 480V

General Specifications

120 / 240 Vac 1 & 3 Phase (85 - 265 V)	Continuous Current (Arms)	Peak Current (Arms)	Drive Continuous Output Power Capacity (Watts)	Internal Regen (Watts) (Ohms)		Height mm (in)	Width mm (in)	Depth mm (in)	Depth with Cable Bend Radius mm (in)
AKD-x00306	3	9	1100	0	0	168 (6.61)	59 (2.32)	156 (6.14)	184 (7.24)
AKD-x00606	6	18	2000	0	0	168 (6.61)	59 (2.32)	156 (6.14)	184 (7.24)
AKD-x01206	12	30	4000	100	15	196 (7.72)	78 (3.07)	187 (7.36)	215 (8.46)
AKD-x02406	24	48	8000	200	8	247 (9.72)	100 (3.94)	228 (8.98)	265 (10.43)
240/480 Vac 3 Phase (187-528 V)	Continuous Current (Arms)	Peak Current (Arms)	Drive Continuous Output Power Capacity (Watts)	Internal Regen (Watts) (Ohms)		Height mm (in)	Width mm (in)	Depth mm (in)	Depth with Cable Bend Radius mm (in)
AKD-x00307	3	9	2000	100	33	256 (10.08)	70 (2.76)	185 (7.28)	221 (8.70)
AKD-x00607	6	18	4000	100	33	256 (10.08)	70 (2.76)	185 (7.28)	221 (8.70)
AKD-x01207	12	30	8000	100	33	256 (10.08)	70 (2.76)	185 (7.28)	221 (8.70)
AKD-x02407	24	48	16,000	200	23	306 (12.01)	105 (4.13)	228 (8.98)	264 (10.39)
AKD-x04807	48	96	35,000	—	—	385 (15.16)	185 (7.28)	225 (8.86)	260 (10.23)

Note: For complete AKD model nomenclature, refer to pages 46.



AKD[®] Servo Drive

Range of Coverage

When you pair the AKD servo drive with any of our Kollmorgen motors or linear actuators, you'll achieve optimized performance. From 3 to 48 Arms continuous current and 9 to 96 Arms peak current, the feature-rich AKD provides a solution for nearly any application.

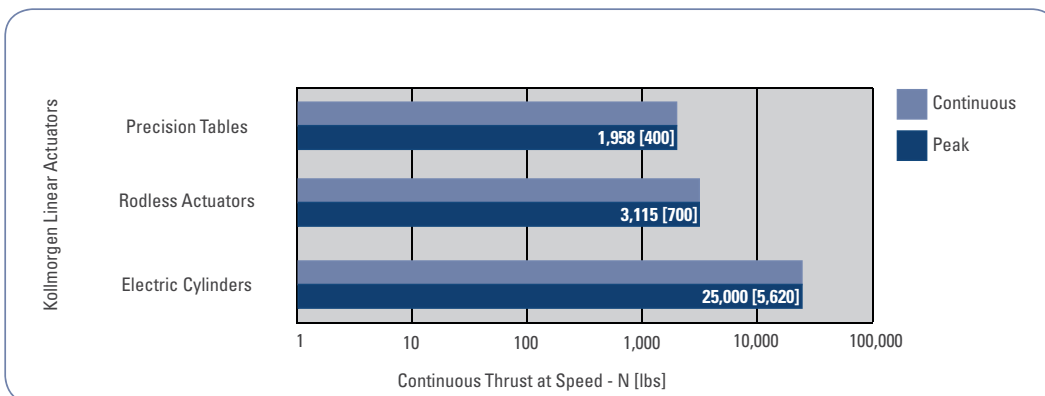
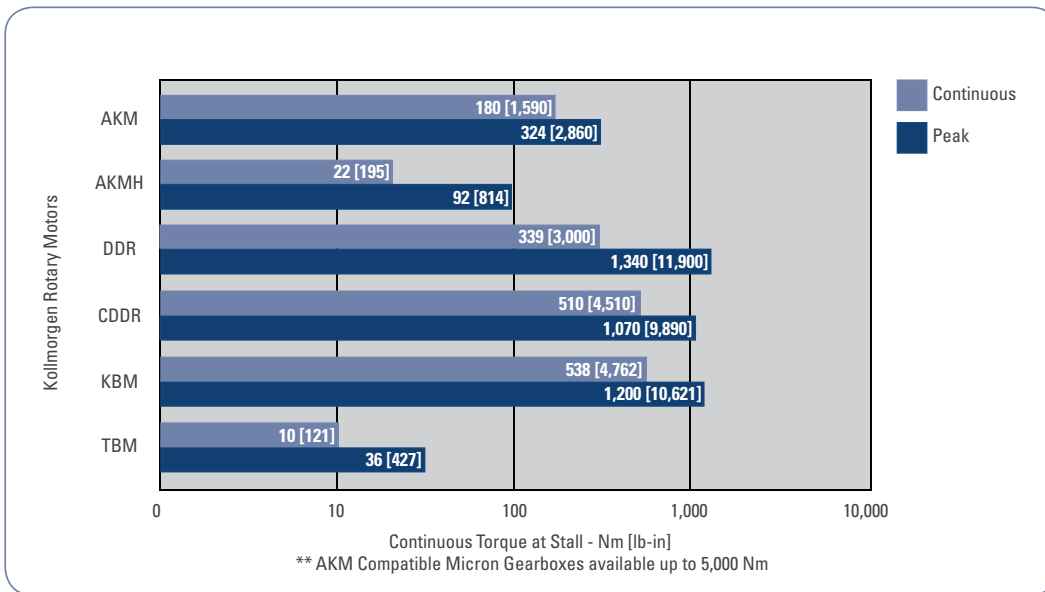
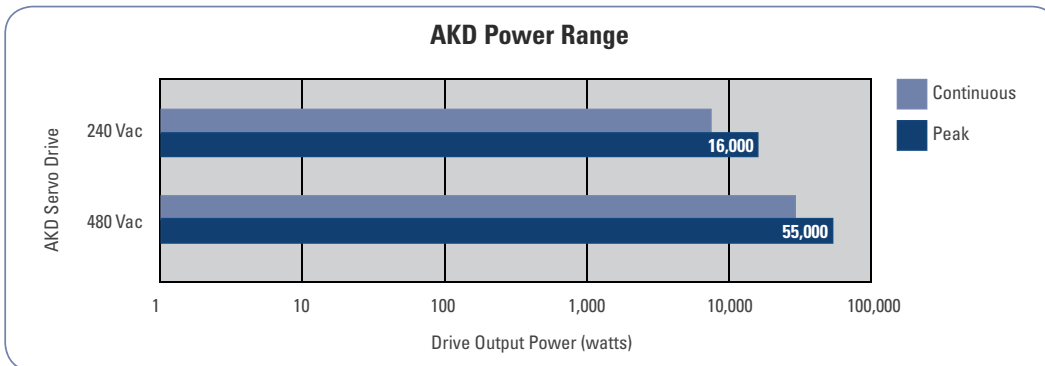

Feedback & I/O

AKD® servo drive is specifically designed with the versatility, communications, and power you need to expand machine performance and increase integration speeds. Motor set-up is plug-and-play and multiple Ethernet connectivity options provide both open and closed protocols. Online troubleshooting and data verification enable faster, bug-proof programming. And a broad power range in a smaller, compact design allows you to use these robust drives with a single interface while experiencing industry-leading, high-performance servo loops.

AKD Specifications

	Standard Drive	With I/O expansion - AKD-T only
Encoder Output or AUX Encoder Input	2.5 MHz Maximum line frequency	
Feedback	Smart Feedback Device (SFD), EnDat2.2, EnDat2.1, BiSS, analog Sine/Cos encoder, incremental encoder, HIPERFACE®, and resolver	
Logic supply	24 Vdc	
Digital input (24 Vdc)	8 (1 dedicated to enable)	20 (1 dedicated to enable)
Digital output (24 Vdc)	3 (1 dedicated to fault relay)	13 (1 dedicated to fault relay)
Analog input (+/- 10 Vdc, 16-bit)	1	2
Analog output (+/- 10 Vdc, 16-bit)	1	2
Programmable inputs	7	19
Programmable outputs	2	12
Sink/Source inputs/outputs	Yes	Yes

AKD® Servo Drive

AKD – B 003 06 – NB AN – 0000

AKD Series

Version

- B = Base drive
- C = Central power supply for AKD-N (Requires CB Extension)
- N = Decentralized drive (Requires DB, DF, or DS Extension)
- P = Position indexer (motion tasking)
- T = AKD BASIC Language Programmable drive (Requires IC or NB Extension)
- M = Multi-axis Master Drive (Requires MC Extension option, and EC Connectivity option)

Current Rating

- 003 = 3 Amp
- 006 = 6 Amp
- 010 = 10kW (for AKD-C, this field refers to power.)
- 012 = 12 Amp
- 024 = 24 Amp
- 048 = 48 Amp

Voltage

- 06 = 120/240 Vac 1Ø/3Ø (24 Amp Drive: 240 Vac 3Ø only)
- 07 = 240/480 Vac 3Ø (Version C: 07 = 400/480 Vac 3Ø | Version N: 07 = 560/680 Vdc)

Variants

0000 = Standard

Connectivity*

AN = Analog command	Drive Version Availability
CN = CANopen®	B, P, T
EC = EtherCAT®	P
EI = EtherNet/IP™	C, M, N, P
PN - PROFINET®	P
SQ = SynqNet®	P
	B

*Motion Tasking is included as a free upgrade with CN, EC, EI and PN

Extension

- CB = without extention (AKD-C version only)
- DB = hybrid motor cable (AKD-N version only)
- DF = additional EtherCAT® port + feedback connector (AKD-N version only)
- DS = local STO + feedback connector (AKD-N version only)
- IC = Expanded I/O version and SD card slot (AKD-T version only)
- NB = Without extensions

Note: Options shown in blue text are considered standard.

MOTIONEERING® Online

MOTIONEERING® Online – Kollmorgen has revamped, modernized and put online one of the most respected applications sizing programs of the last 20 years. You now can access this application sizing and selection tool wherever you have access to the internet. MOTIONEERING Online is just a start of a series of releases that will empower you to optimize solutions for your toughest applications. Sizing frameless motors and drive systems has never been easier. Using a mechanism project concept for collecting and saving multiple axes of load information, MOTIONEERING® Online can automatically calculate application results and compare against a catalog of systems - recommending the most optimized set of Kollmorgen system solutions available.

Versatile units-of-measure selection options for mechanism and motion profile data-entry, with the ability to convert data into other available units, makes this a convenient international tool. A user-friendly Help file teaches program functions and algorithms used to provide results.

Mechanism Projects

- Direct drive entry, lead screw, conveyor
- Rack and pinion, nip rolls
- Direct Drive Rotary
- Electric Cylinder
- Direct data entry



Solution Set Search Screen

- Color-coded indication of system’s ability to meet application requirements
- Review system components specifications
- Save, print, or create a pdf application report
- Evaluate system performance curve with application points

MOTIONEERING® Online Features:

- Inertia Calculator - lets you build up inertia based on odd shapes by additive or subtractive methods
- Custom Motion Profile - easy to add entire segments or copy segments to repeat
- Environmental Factor - takes into account your ambient temperature
- Project by Project Units - You can tailor your units on a project by project basis, or use the global units settings

MOTIONEERING Online Supported Browsers

- IE, Chrome, Firefox, Safari



www.kollmorgen.com/motioneering

About Kollmorgen

Since its founding in 1916, Kollmorgen's innovative solutions have brought big ideas to life, kept the world safer, and improved peoples' lives. Today, its world-class knowledge of motion systems and components, industry-leading quality, and deep expertise in linking and integrating standard and custom products continually delivers breakthrough motion solutions that are unmatched in performance, reliability, and ease-of-use. This gives machine builders around the world an irrefutable marketplace advantage and provides their customers with ultimate peace-of-mind.

For assistance with your application needs
in North America, contact us at: 540-633-3545,
support@kollmorgen.com or visit
www.kollmorgen.com for a global contact list.



KOLLMORGEN®

Because Motion Matters™

Kollmorgen
203A West Rock Road
Radford, VA 24141 USA
Phone: 1-540-633-3545
Fax: 1-540-639-4162

Kollmorgen Europe GmbH
Pempelfurtstraße 1
40880 Ratingen
Germany
Phone: +49 (0) 2102 9394 0
Fax: +49 (0) 2102 9394 3155

Kollmorgen Asia
Floor 4, Building 9, No. 518,
North Fuquan Road, Changning District,
Shanghai 200335, China
Phone: + 86 400 661 2802

Kollmorgen Aerospace and Defense
501 West Main Street
Radford, VA 24141 USA
Phone: 1-540-731-5668
Fax: 1-540-731-5679