

KBM 60 Frameless Motors

The KBM(S)-60 series has a patented slot / pole combination offering extremely high continuous torque capability while still maintaining very low total harmonic distortion. The higher pole count and excellent torque / volume ratio makes the KBM(S)-60 an ideal fit for direct drive applications requiring high torque at low to moderate speeds.

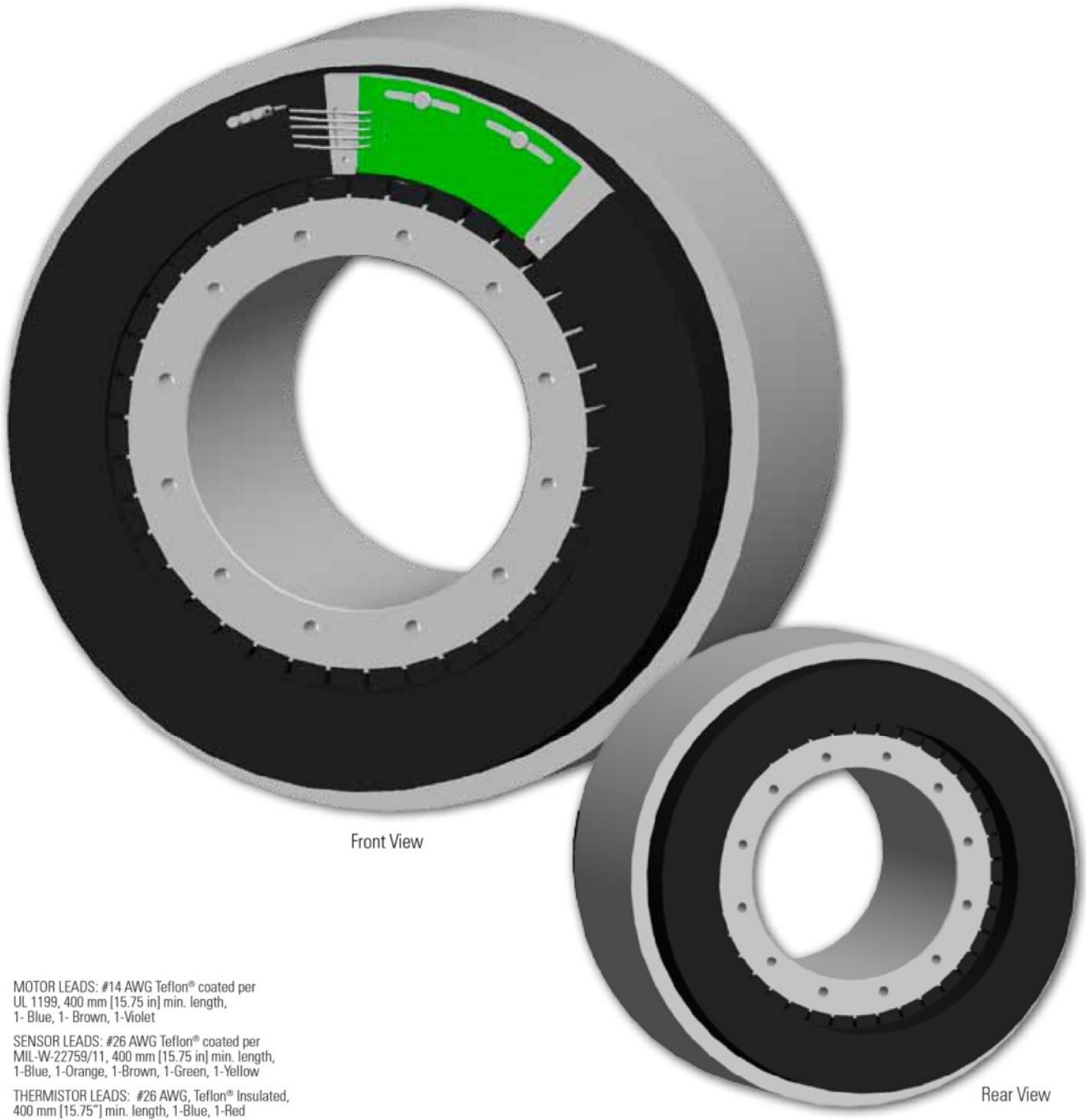

MOTOR LEADS: #14 AWG Teflon® coated per UL 1199, 400 mm [15.75 in] min. length, 1- Blue, 1- Brown, 1-Violet

SENSOR LEADS: #26 AWG Teflon® coated per MIL-W-22759/11, 400 mm [15.75 in] min. length, 1-Blue, 1-Orange, 1-Brown, 1-Green, 1-Yellow

THERMISTOR LEADS: #26 AWG, Teflon® Insulated, 400 mm [15.75"] min. length, 1-Blue, 1-Red

KBM 60 Outline Drawings

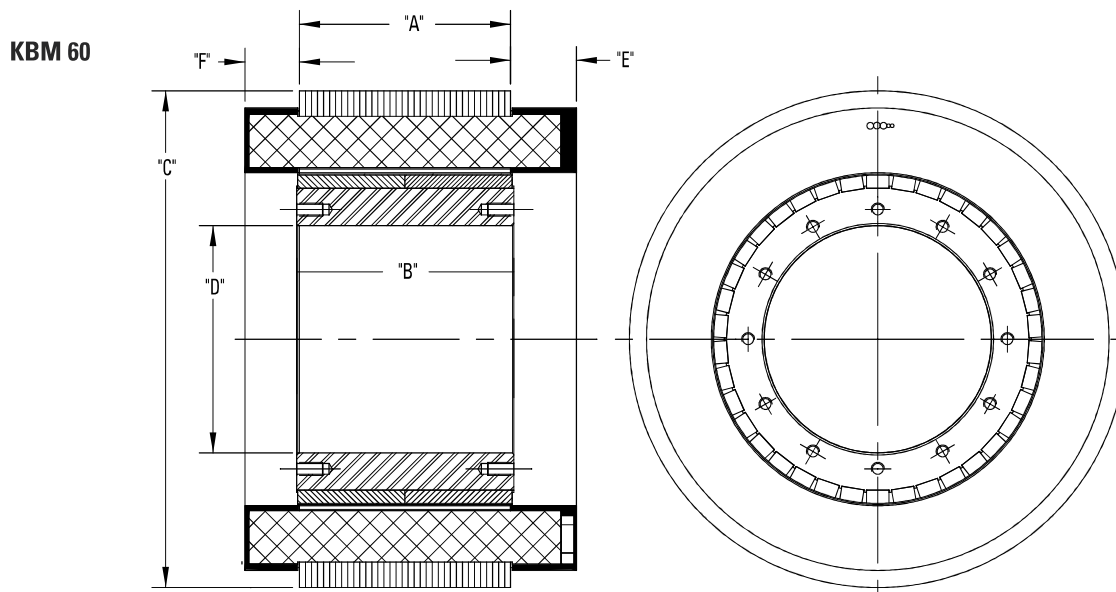

Model Number	"A" mm[inch]	"B" mm[inch]	Ø "C" mm[inch]	Ø "D" mm[inch]	"E" MAX mm[inch]	"F" MAX mm[inch]
KBM-60X00	26.62 [1.048]	29.39 [1.157]	229.85 [9.049]	105.05 [4.136]	30.48 [1.200]	25.15 [.990]
KBM-60X01	48.11 [1.894]	50.88 [2.003]				
KBM-60X02	97.71 [3.847]	100.48 [3.956]				
KBM-60X03	147.32 [5.800]	150.09 [5.909]				

All dimensions are nominal. For more detailed and interactive 3D models with 2D product views, visit www.kollmorgen.com/kbm

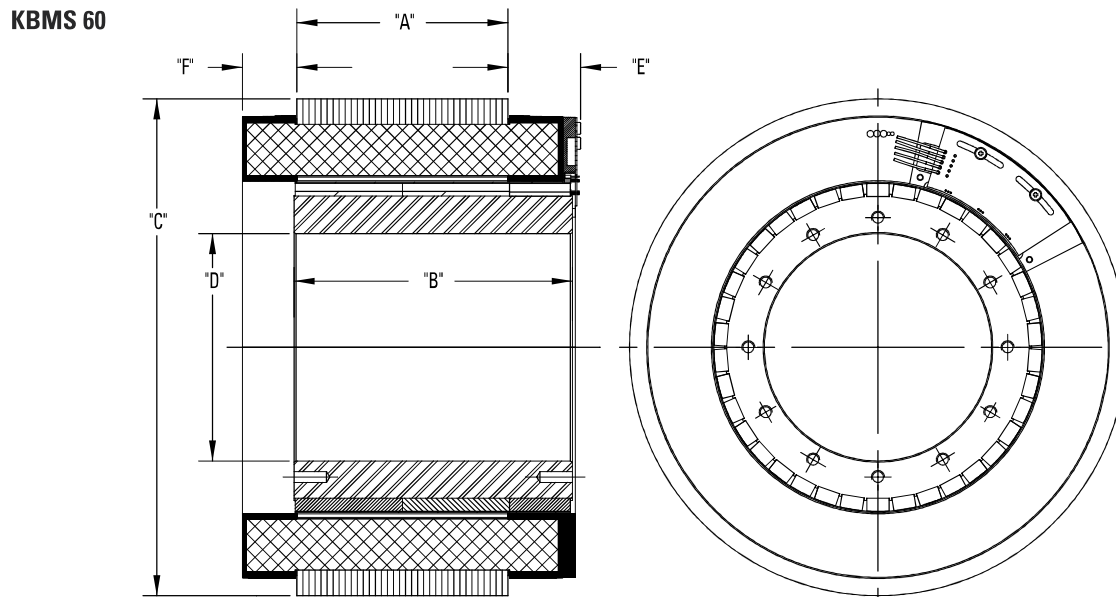

Model Number	"A" mm[inch]	"B" mm[inch]	Ø "C" mm[inch]	Ø "D" mm[inch]	"E" MAX mm[inch]	"F" MAX mm[inch]
KBMS-60X00	26.62 [1.048]	57.53 [2.265]	229.85 [9.049]	105.05 [4.136]	33.65 [1.325]	25.15 [.990]
KBMS-60X01	48.11 [1.894]	78.99 [3.110]				
KBMS-60X02	97.71 [3.847]	128.78 [5.070]				
KBMS-60X03	147.32 [5.800]	178.31 [7.020]				

All dimensions are nominal. For more detailed and interactive 3D models with 2D product views, visit www.kollmorgen.com/kbm

KBM 60 Performance Data

KBM(S)-60XXX PERFORMANCE DATA & MOTOR PARAMETERS									
Motor Parameter	Symbol	Units	TOL	KBM(S)-60X00-X			KBM(S)-60X01-X		
				A	B	C	A	B	C
Continuous Stall Torque at 25°C Amb. (1)	Tc	Nm	NOM	29.4	29.4	29.4	53.9	53.9	53.9
		lb-ft		21.7	21.7	21.7	39.8	39.8	39.8
Continuous Current	Ic	Arms	NOM	13.7	16.8	22.5	13.7	16.9	22.7
Peak Stall Torque (25°C winding temp)	Tp	Nm	NOM	69.1	69.1	69.1	127	127	127
		lb-ft		51.0	51.0	51.0	93.8	93.8	93.8
Peak Current	Ip	Arms	NOM	40.0	50.4	63.6	40.0	50.4	78.0
Rated Continuous Output Power at 25°C Amb. (1)	P Rated	Watts		2960	2960	2960	4165	4165	4580
	HP Rated	HP		3.97	3.97	3.97	5.58	5.58	6.14
Speed at Rated Power	N Rated	RPM		1700	1700	1700	1600	1600	1300
Torque Sensitivity (2)	Kt	Nm / Arms	+/-10%	2.23	1.81	1.35	4.04	3.27	2.43
		lb-ft / Arms		1.65	1.33	0.994	2.98	2.41	1.80
Back EMF Constant	Kb	Vrms/kRPM	+/- 10%	135	110	81.3	244	198	147
Motor Constant	Km	Nm/√watt	+/-10%	2.17	2.17	2.17	3.44	3.44	3.44
		lb-ft /√watt		1.60	1.60	1.60	2.54	2.54	2.54
Resistance (line to line)	Rm	Ohms	+/- 10%	0.704	0.453	0.267	0.916	0.590	0.335
Inductance	Lm	mH		4.5	3.0	1.6	8.0	5.1	2.8
Inertia (KBM)	Jm	Kg-m ²		9.53E-03			1.63E-02		
		lb-ft-s ²		7.03E-03			1.20E-2		
Weight (KBM)	Wt	Kg		8.30			13.2		
		lb		18.3			29.0		
Inertia (KBMS)	Jm	Kg-m ²		1.88E-02			2.56E-2		
		lb-ft-s ²		1.39E-02			1.89E-2		
Weight (KBMS)	Wt	Kg		10.4			15.3		
		lb		22.9			33.8		
Max Static Friction	Tf	Nm		0.750			1.36		
		lb-ft		0.550			1.00		
Cogging Friction (peak-to-peak)	Tcog	Nm		0.560			1.02		
		lb-ft		0.410			0.750		
Viscous Damping	Fi	Nm/ kRPM		0.870			0.230		
		lb-ft / kRPM		0.640			0.170		
Thermal Resistance (4)	TPR	°C / watt		0.452			0.336		
Number of Poles	P	-		38			38		
Recommended Kollmorgen AKD Drive				02407	02407	02406	02407	02407	02406
Recommended Kollmorgen S700 Drive									
Voltage Req'd at Rated Output	Vac Input	Vac		480	400	240	480	400	240
Peak Stall Torque (4) (Motor with Drive)	Tp Drive	Nm	+/-10%	69.1	63.0	53.0	127	120	96
		lb-ft		51.0	46.5	39.1	93.8	88.5	70.8
Cont. Stall Torque (4) (Motor with Drive)	Tc Drive	Nm	+/-10%	29.4	29.4	29.4	53.9	53.9	53.9
		lb-ft		21.7	21.7	21.7	39.8	39.8	39.8

- Notes
- 1) Winding temperature = 155°C at continuous stall, at rated output, and for performance curves.
 - 2) To calculate no-load Kt and Kb at 25°C, multiply by 1.064.
 - 3) TPR assumes motor is housed and mounted to a 12" x 12" x 3/4" heat sink or equivalent.
 - 4) Peak & Continuous Torques may be limited by drive current, see www.kollmorgen.com for complete drive ratings.

KBM(S)-60XXX PERFORMANCE DATA & MOTOR PARAMETERS							
Motor Parameter	Symbol	Units	TOL	KBM(S)-60X02-X		KBM(S)-60X03-X	
				A	B	A	B
Continuous Stall Torque at 25°C Amb. (1)	Tc	Nm	NOM	108	108	154	154
		lb-ft		79.7	79.7	114	114
Continuous Current	Ic	Arms	NOM	16.3	19.6	18.6	24.0
Peak Stall Torque (25°C winding temp)	Tp	Nm	NOM	243	243	393	393
		lb-ft		179	179	290	290
Peak Current	Ip	Arms	NOM	50.4	60.4	63.3	76.8
Rated Continuous Output Power at 25°C Amb. (1)	P Rated	Watts		6985	6985	8350	8420
	HP Rated	HP		9.36	9.36	11.2	11.3
Speed at Rated Power	N Rated	RPM		885	885	720	730
Torque Sensitivity (2)	Kt	Nm / Arms	+/-10%	6.79	5.66	8.50	7.01
		lb-ft / Arms		5.01	4.17	6.27	5.17
Back EMF Constant	Kb	Vrms/kRPM	+/- 10%	411	342	514	424
Motor Constant	Km	Nm/√watt	+/-10%	5.78	5.78	7.46	7.39
		lb-ft /√watt		4.26	4.26	5.50	5.45
Resistance (line to line)	Rm	Ohms	+/- 10%	0.921	0.638	0.867	0.600
Inductance	Lm	mH		11	7.6	11	7.5
Inertia (KBM)	Jm	Kg-m ²		3.17E-2		4.75E-2	
		lb-ft-s ²		2.34E-2		3.50E-2	
Weight (KBM)	Wt	Kg		25.2		37.2	
		lb		55.6		82.0	
Inertia (KBMS)	Jm	Kg-m ²		4.20E-2		5.29E-2	
		lb-ft-s ²		3.10E-2		3.90E-2	
Weight (KBMS)	Wt	Kg		27.9		39.8	
		lb		61.4		87.7	
Max Static Friction	Tf	Nm		2.71		4.07	
		lb-ft		2.00		3.00	
Cogging Friction (peak-to-peak)	Tcog	Nm		2.03		3.05	
		lb-ft		1.50		2.25	
Viscous Damping	Fi	Nm/ kRPM		0.461		0.691	
		lb-ft / kRPM		0.340		0.510	
Thermal Resistance (4)	TPR	°C / watt		0.236		0.192	
Number of Poles	P	-		38		38	
Recommended Kollmorgen AKD Drive				02407	02407	02407	
Recommended Kollmorgen S700 Drive							S748
Voltage Req'd at Rated Output	Vac Input	Vac		480	400	480	400
Peak Stall Torque (4) (Motor with Drive)	Tp Drive	Nm	+/-10%	249	214	316	393
		lb-ft		184	158	233	290
Cont. Stall Torque (4) (Motor with Drive)	Tc Drive	Nm	+/-10%	108	108	154	154
		lb-ft		79.7	79.7	114	114

- Notes
- 1) Winding temperature = 155°C at continuous stall, at rated output, and for performance curves.
 - 2) To calculate no-load Kt and Kb at 25°C, multiply by 1.064.
 - 3) TPR assumes motor is housed and mounted to a 12" x 12" x 3/4" heat sink or equivalent.
 - 4) Peak & Continuous Torques may be limited by drive current, see www.kollmorgen.com for complete drive ratings.

KBM 60 Performance Curves

Continuous duty capability for 130°C rise in a 25°C ambient using recommended AKD, or S700, servo drive and sinusoidal commutation.

**KBM(S)-60X00
Continuous Torque**

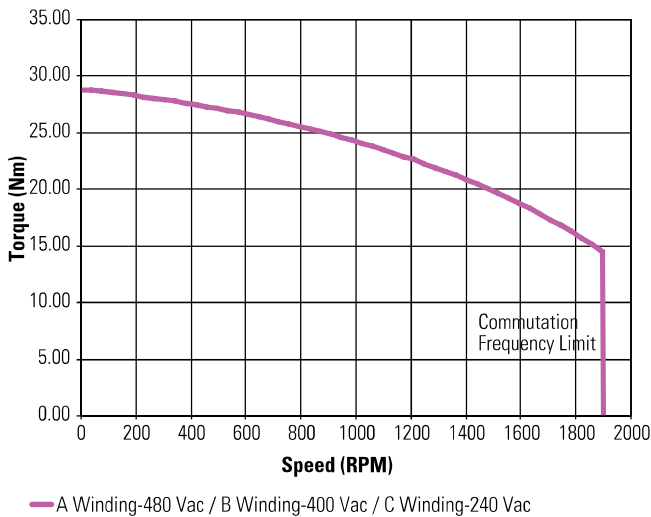

**KBM(S)-60X01
Continuous Torque**

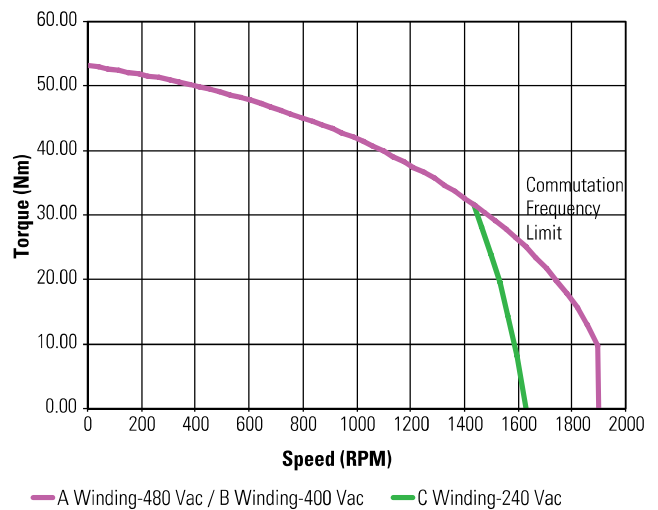

**KBM(S)-60X02
Continuous Torque**

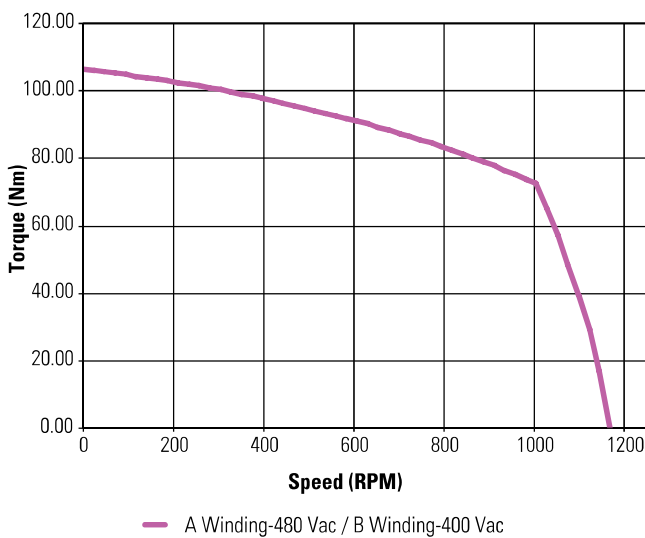

**KBM(S)-60X03
Continuous Torque**

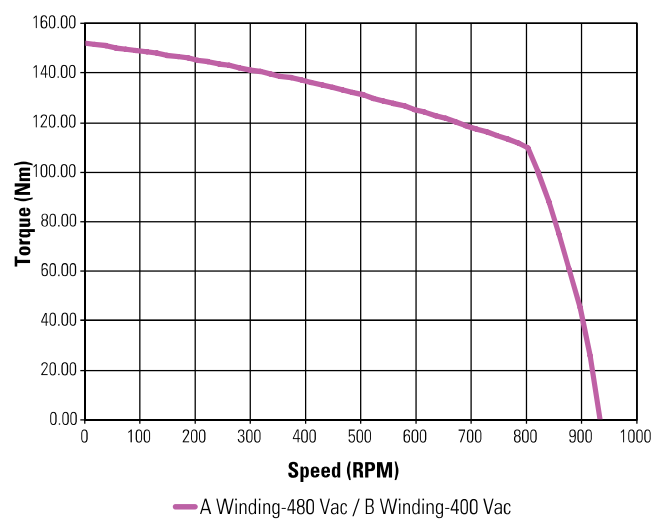

Low Voltage optimized windings available.