

DIGITAL SERVO DRIVE FOR BRUSH & BRUSHLESS MOTORS

CONTROL MODES

- Cyclic Synchronous Position-Velocity-Torque (CSP, CSV, CST)
- Profile Position-Velocity-Torque, Interpolated Position, Homing
- Camming, Gearing
- Indexer



COMMAND INTERFACE

- CANopen application protocol over EtherCAT (CoE)
- ASCII and discrete I/O
- Stepper commands
- ±10V position/velocity/torque
- PWM velocity/torque command
- Master encoder (Gearing/Camming)

COMMUNICATIONS

- EtherCAT
- RS-232

FEEDBACK

Incremental Encoders

- Digital quad A/B
- Analog Sin/Cos
- Panasonic Incremental A Format
- Aux. quad A/B encoder / encoder out

Absolute Encoders

- SSI, EnDat, Absolute A, Tamagawa & Panasonic Absolute A, Sanyo Denki Absolute A, BiSS (B & C)

Other

- Digital Halls

I/O DIGITAL

- 8 High-speed inputs
- 2 Motor over-temp inputs
- 8 Opto-Isolated inputs
- 5 Opto-Isolated outputs
- 2 Opto-Isolated brake outputs

ANALOG

- 2 Reference Inputs, 12-bit

SAFE TORQUE OFF (STO)

- SIL 3, Category 3, PL d

DIMENSIONS: IN [MM]

- 6.78 x 4.70 x 1.74 [172.1 x 119.3 x 44.1] no heatsink
- 6.78 x 4.70 x 3.14 [172.1 x 119.3 x 79.8] with heatsink



Model	Ip	Ic	Vdc
BE2-090-06	6	3	90
BE2-090-14	14	7	90
BE2-090-20	20	10	90

Current ratings are for each axis
Add -R for resolver feedback option

DESCRIPTION

The BE2 models are high-performance, DC powered drives for position, velocity, and torque control of brushless and brush motors via EtherCAT, an Ethernet-based fieldbus. These drives operate as EtherCAT slaves using the CANopen application protocol over EtherCAT (CoE) protocol of DSP-402 for motion control devices. Supported modes include: Cyclic Synchronous Position-Velocity-Torque, Profile Position-Velocity-Torque, Interpolated Position Mode (PVT), and Homing.

Feedback from both incremental and absolute encoders is supported. A multi-mode encoder port functions as an input or output depending on the drive's basic setup.

There are ten non-isolated inputs and eight isolated inputs. All inputs have programmable active levels. Five opto-isolated outputs [OUT1~5] have individual +/- connections. Two isolated MOSFET brake outputs [OUT6~7] are programmable for other functions and have flyback diodes to the Brake 24V input for driving inductive loads.

Drive power is transformer-isolated DC from regulated or unregulated power supplies. An AuxHV input is provided for "keep-alive" operation permitting the drive power stage to be completely powered down without losing position information, or communications with the control system.

GENERAL SPECIFICATIONS

Test conditions: Load = Wye connected load: 2 mH + 2 Ω line-line. Ambient temperature = 25°C, +HV = HV_{max}

MODEL	BE2-090-06	BE2-090-14	BE2-090-20	
OUTPUT POWER (EACH AXIS)				
Peak Current	6 (4.2)	14 (9.9)	20 (14.4)	Adc (Arms-sine), ±5%
Peak time	1			Sec
Continuous current (Note 1)	3 (2.1)	7 (4.9)	10 (7.1)	Adc (Arms-sine) per phase
INPUT POWER				
HVmin~HVmax	+14 to +90	+14 to +90	+14 to +90	Vdc Transformer-isolated
Ipeak	12	28	40	Adc (1 sec) peak
Icont	6	14	20	Adc continuous
Aux HV	+14 to +90 Vdc, 4 W (Typ, no load on encoder +5V outputs), 11 W, (Max, both encoder +5V @ 500 mA)			Optional, not required for operation
DIGITAL CONTROL				
Digital Control Loops	Current, velocity, position. 100% digital loop control			
Sampling rate (time)	Current loop: 16 kHz (62.5 μs), Velocity & position loops: 4 kHz (250 μs)			
Bus voltage compensation	Changes in bus or mains voltage do not affect bandwidth			
Minimum load inductance	200 μH line-line			
COMMAND INPUTS (NOTE: DIGITAL INPUT FUNCTIONS ARE PROGRAMMABLE)				
<i>Distributed Control Modes</i>				
CANopen application protocol over EtherCAT (CoE)	Cyclic Synchronous Position-Velocity-Torque, Profile Position-Velocity-Torque, Interpolated Position, Homing			
<i>Stand-alone mode</i>				
Analog torque, velocity, position reference	±10 Vdc, 12-bit resolution		Dedicated differential analog input	
Digital position reference	Pulse/Direction, CW/CCW		Stepper commands (2 MHz maximum rate)	
	Quad A/B Encoder		2 M line/sec, 8 Mcount/sec (after quadrature)	
	PWM, Polarity		PWM = 0% - 100%, Polarity = 1/0	
Digital torque & velocity reference	PWM 50%		PWM = 50% ±50%, no polarity signal required	
	PWM frequency range		1 kHz minimum, 100 kHz maximum	
	PWM minimum pulse width		220 ns	
Indexing	Up to 32 sequences can be launched from inputs or ASCII commands.			
Camming	Up to 10 CAM tables can be stored in flash memory			
ASCII	RS-232, DTE, 9600~115,200 Baud, 3-wire, RJ-11 connector			
DIGITAL INPUTS				
Number 18				
[IN1,2,10,11]	Digital, non-isolated, Schmitt trigger, 1.5 μs RC filter, 24 Vdc compatible, programmable pull-up/down to +5 Vdc/ground, 74HC2G14, Vcc = 5 Vdc, Vt+ = 2.5~3.5 Vdc, VT- = 1.3~2.2 Vdc, VH = 0.7~1.5 Vdc			
[IN3,4,12,13]	Digital, non-isolated, programmable as single-ended or differential pairs, 100 ns RC filter, 12 Vdc max, programmable pull-up/down per input to +5 Vdc/ground, MAX3096, Vcc = 3.3 Vdc			
[IN5~8,14~17]	SE: Vin-LO ≤ 2.3 Vdc, Vin-HI ≥ 2.7 Vdc, VH = 45 mV typ, DIFF: Vin-LO ≤ 200 mVdc, Vin-HI ≥ 200 mVdc, VH = 45 mV typ			
[IN9,18]	Digital, opto-isolated, single-ended, ±15~30 Vdc compatible, bi-polar, 2 groups of 4, each with a common terminal			
	Rated impulse ≥ 800 V, Vin-LO ≤ 6.0 Vdc, Vin-HI ≥ 10.0 Vdc, Input current ±3.6 mA @ ±24 Vdc, typical			
Functions	Default as motor overtemp inputs on feedback connectors, 12 Vdc max, 74HC2G14, Vcc = 5 Vdc, 330 μs RC filter, 4.99k pullup to +5 Vdc, Vt+ = 2.5~3.5 Vdc, VT- = 1.3~2.2 Vdc, VH = 0.7~1.5 Vdc			
	All inputs are programmable, [IN1 & IN10] default to drive axes A & B Enable function and are programmable			
ANALOG INPUTS				
Number	2			
[AIN1~2]	Differential, ±10 Vdc, 5 kΩ input impedance, 12-bit resolution			
SAFE TORQUE OFF (STO)				
Function	PWM outputs are inactive and current to the motor will not be possible when the STO function is asserted			
Standard	Designed to IEC-61508-1, IEC-61508-2, IEC-61800-5-2, ISO-13849-1			
Safety Integrity Level	SIL 3, Category 3, Performance level d			
Inputs	2 two-terminal: STO-IN1+, STO-IN1-, STO-IN2+, STO-IN2-			
Type	Opto-isolators, 24V compatible, Vin-LO ≤ 6.0 Vdc or open, Vin-HI ≥ 15.0 Vdc,			
Input current (typical)	STO-IN1: 9.0 mA, STO-IN2: 4.5 mA			
Response time	2 ms from Vin ≤ 6.0 Vdc to interruption of energy supplied to motor			
Reference	Complete information and specifications are in the 16-01338 Accelnet & Stepmet Plus Panels STO Manual			
DIGITAL OUTPUTS				
Number	7			
[OUT1~5]	Opto-isolated SSR, two-terminal, 300 mA max, 24 V tolerant, Rated impulse ≥ 800 V, series 1 Ω resistor			
[OUT6~7]	Opto-isolated MOSFET, default as motor brake control, current-sinking, 1 Adc max, flyback diodes to +24 V external power supply for driving inductive loads			
	Programmable for other functions if not used for brake			
RS-232 PORT				
Signals	RxD, TxD, Gnd in 6-position, 4-contact RJ-11 style modular connector, non-isolated, common to Signal Ground			
Mode	Full-duplex, DTE serial communication port for drive setup and control, 9,600 to 115,200 Baud			
Protocol	Binary and ASCII formats			
ETHERCAT PORTS				
Format	Dual RJ-45 receptacles, 100BASE-TX			
Protocol	EtherCAT, CANopen application protocol over EtherCAT (CoE), CiA-402 for motion control devices			



NOTES:

1) Heatsink or forced-air required for continuous current rating

GENERAL SPECIFICATIONS

DC POWER OUTPUTS

Number: Ratings
Connections

2: +5 Vdc, 500 mA max each output, thermal and short-circuit protected
Axis A: J1-17, J1-32, J7-6, J7-17; combined current from these pins cannot exceed 500 mA
Axis B: J1-23, J1-38, J8-6, J8-17; combined current from these pins cannot exceed 500 mA

INDICATORS

AMP Bicolor LED, drive state indicated by color, and blinking or non-blinking condition
RUN Green LED, status of EtherCAT state-machine (ESM)
ERR Red LED, shows errors due to time-outs, unsolicited state changes, or local errors
L/A Green LED, Link/Act, shows the state of the physical link and activity on the link (EtherCAT connection)
RUN, ERR, and L/A LED colors and blink codes conform to ETG.1300 S(R) V1.1.0

PROTECTIONS

HV Overvoltage	+HV > 90 Vdc	Drive outputs turn off until +HV < 90 Vdc (See Input Power for HV _{max})
HV Undervoltage	+HV < +14 Vdc	Drive outputs turn off until +HV > +14 Vdc
Drive over temperature	Heat plate > 70°C.	Drive outputs turn off
Short circuits	Output to output, output to ground, internal PWM bridge faults	
I ² T Current limiting	Programmable: continuous current, peak current, peak time	
Motor over temperature	Digital inputs programmable to detect motor temperature switch	
Feedback Loss	Inadequate analog encoder amplitude or missing incremental encoder signals	

MECHANICAL & ENVIRONMENTAL

Size IN [MM]	6.78 x 4.70 x 1.74 [172.1 x 119.3 x 44.1] without heatsink 6.78 x 4.70 x 3.14 [172.1 x 119.3 x 79.8] with heatsink
Weight LB[KG]	1.5 [0.68] without heatsink, 2.75 [1.25] with heatsink
Ambient temperature	0 to +45C operating, -40 to +85C storage
Humidity	0 to 95%, non-condensing
Vibration	2 g peak, 10~500 Hz (sine), IEC60068-2-6
Shock	10 g, 10 ms, half-sine pulse, IEC60068-2-27
Contaminants	Pollution degree 2
Environment	IEC 68-2
Cooling	Heat sink and/or forced air cooling required for continuous power output

AGENCY STANDARDS CONFORMANCE

Standards and Directives

Functional Safety

IEC 61508-1, IEC 61508-2, IEC 61508-3, IEC 61508-4 (SIL 3)
Directive 2006/42/EC (Machinery)
ISO 13849-1 (Cat 3, PL d)
IEC 61800-5-2 (SIL3)

Product Safety

Directive 2014/35/EU (Low Voltage)
IEC 61800-5-1

EMC

Directive 2014/30/EU (EMC)
IEC 61800-3

Restriction of the Use of Certain Hazardous Substances (RoHS)

Directive 2011/65/EU (RoHS II)

Approvals

UL and cUL recognized component to:
UL 61800-5-1, 1st Ed.

TÜV SÜD Functional Safety to:

IEC 61508-1, IEC 61508-2, IEC 61508-3, IEC 61508-4 (SIL 3)
ISO 13849-1 (Cat 3, PL d)



DANGER

Refer to the 16-01338 Accelnet & Stepnet Plus Panels STO Manual

The information provided in the 16-01338 Accelnet & Stepnet Plus Panels STO Manual must be considered for any application using the drive's STO feature.

FAILURE TO HEED THIS WARNING CAN CAUSE EQUIPMENT DAMAGE, INJURY, OR DEATH.

FEEDBACK: BE2 MODELS

FEEDBACK

Incremental:

Digital Incremental Encoder	Quadrature signals, (A, /A, B, /B, X, /X), differential (X, /X Index signals not required) 5 MHz maximum line frequency (20 M counts/sec)
Analog Incremental Encoder	Sin/cos format (sin+, sin-, cos+, cos-), differential, 1 V _{peak-peak} , ServoTube motor compatible, BW > 300 kHz, 121 Ω terminating resistor between complementary inputs Digital Index (X, /X) input

Absolute: Two absolute encoders, one per axis are supported. Dual absolute encoders on one axis are not supported.

SSI	Clock (X, /X), Data (S, /S) signals, 4-wire, clock output from BE2, data returned from encoder
EnDAT	Clock (X, /X), Data (S, /S), sin/cos (sin+, sin-, cos+, cos-) signals
Absolute A	Tamagawa Absolute A, Panasonic Absolute A Format, Sanyo Denki Absolute A SD+, SD- (S, /S) signals, 2.5 or 4 MHz, 2-wire half-duplex communication Position feedback: 13-bit resolution per rev, 16 bit revolution counter (29 bit absolute position data) Status data for encoder operating conditions and errors
BISS (B&C)	MA+, MA- (X, /X), SL+, SL- (S, /S) signals, 4-wire, clock output from BE2, data returned from encoder

Terminators, Digital Encoders	A~/A, B~/B inputs: 121 Ω X~/X inputs: 130 Ω S~/S inputs: 221 Ω X, S inputs: 1 kΩ pull-up to +5V /X, /S inputs: 1 kΩ pull-down to ground
-------------------------------	---

DIGITAL HALLS

Type	Digital, single-ended, 120° electrical phase difference between U-V-W signals, Schmitt trigger, 1 μs RC filter, 24 Vdc compatible, programmable pull-up/down to +5 Vdc/ground, V _{t+} = 2.5~3.5 Vdc, V _{t-} = 1.3~2.2 Vdc, V _H = 0.7~1.5 Vdc
Inputs	10 kΩ pullups to +5 Vdc, 1 μs RC filter to Schmitt trigger inverters

MULTI-MODE ENCODER PORT

As Input	Digital quadrature encoder (A, /A, B, /B, X, /X), 5 MHz maximum line frequency (20 M counts/sec), MAX3097 line receiver, 1.5 kΩ pull-ups to +5V on X & S inputs, 1.5 kΩ pull-downs to Sgnd on /X & /S inputs Digital absolute encoder (Clk, /Clk, Dat, /Dat) half or full-duplex operation, S & X inputs are used for absolute encoder interface
As Emulated Output	Quadrature encoder emulation with programmable resolution to 4096 lines (16,384 counts) per rev from analog sin/cos encoders or absolute encoders
As Buffered Output	A, /A, B, /B, from MAX3032 differential line driver, X, /X, S, /S from MAX3362 differential line driver Digital A/B/X encoder feedback signals from primary quad encoder are buffered (see line drives above)
Number: Ratings Connections	2: +5 Vdc, 500 mA max each output, thermal and short-circuit protected Axis A: J1-17, J1-32, J7-6, J7-17; combined current from these pins cannot exceed 500 mA Axis B: J1-23, J1-38, J8-6, J8-17; combined current from these pins cannot exceed 500 mA

FEEDBACK: BE2-R MODELS

RESOLVER

Type	Brushless, single-speed, 1:1 to 2:1 programmable transformation ratio
Resolution	14 bits (equivalent to a 4096 line quadrature encoder)
Reference frequency	8.0 kHz
Reference voltage	2.8 Vrms, auto-adjustable by the drive to maximize feedback
Reference maximum current	100 mA
Maximum RPM	10,000+
Sin/Cos inputs	Differential, 54k ±1% differential impedance, 2.0 Vrms, BW ≥ 300 kHz

DIGITAL HALLS

Type	Digital, single-ended, 120° electrical phase difference between U-V-W signals, Schmitt trigger, 1 μs RC filter, 24 Vdc compatible, programmable pull-up/down to +5 Vdc/ground, V _{t+} = 2.5~3.5 Vdc, V _{t-} = 1.3~2.2 Vdc, V _H = 0.7~1.5 Vdc
Inputs	10 kΩ pullups to +5 Vdc, 1 μs RC filter to Schmitt trigger inverters

MULTI-MODE ENCODER PORT

As Input	Digital quadrature encoder (A, /A, B, /B, X, /X), 121 Ω terminating resistors between A & /A, B & /B inputs 18 M-counts/sec, post-quadrature (4.5 M-lines/sec). Digital absolute encoder (Clk, /Clk, Dat, /Dat) half or full-duplex operation, 121 Ω terminating resistors (See above for listing of absolute encoder types. EnDat Sin/Cos signals are not supported)
As Emulated Output	Quadrature encoder emulation with programmable resolution to 4096 lines (65,536 counts) per rev from resolver, A, /A, B, /B, outputs from MAX3032 differential line driver, X, /X, S, /S outputs from MAC3362 drivers

ENCODER POWER SUPPLIES

Number: Ratings Connections	2: +5 Vdc, 500 mA max each output, thermal and short-circuit protected Axis A: J1-17, J1-32, J7-6, J7-17; combined current from these pins cannot exceed 500 mA Axis B: J1-23, J1-38, J8-6, J8-17; combined current from these pins cannot exceed 500 mA
--------------------------------	--

BE2 Models	BE2-R Models
BE2-090-06	BE2-090-06-R
BE2-090-14	BE2-090-14-R
BE2-090-20	BE2-090-20-R

ETHERCAT COMMUNICATIONS

EtherCAT is the open, real-time Ethernet network developed by Beckhoff based on the widely used 100BASE-TX cabling system. EtherCAT enables high-speed control of multiple axes while maintaining tight synchronization of clocks in the nodes.

Data protocol is CANopen application protocol over EtherCAT (CoE) based on DSP-402 for motion control devices. More information on EtherCAT can be found on this web-site: <http://ethercat.org/default.htm>

ETHERCAT CONNECTIONS

Dual RJ-45 sockets accept standard Ethernet cables. The IN port connects to a master, or to the OUT port of a device that is 'upstream', between the Accelnet and the master.

The OUT port connects to 'downstream' nodes. If Accelnet is the last node on a network, only the IN port is used. No terminator is required on the OUT port.

ETHERCAT LEDS (ON RJ-45 CONNECTORS)

RUN Green: Shows the state of the ESM (EtherCAT State Machine)
 Off = Init
 Blinking = Pre-operational
 Single-flash = Safe-operational
 On = Operational

ERR Red: Shows errors such as watchdog timeouts and unsolicited state changes in the BE2 due to local errors.
 Off = EtherCAT communications are working correctly
 Blinking = Invalid configuration, general configuration error
 Single Flash = Local error, slave has changed EtherCAT state autonomously
 Double Flash = PDO or EtherCAT watchdog timeout, or an application watchdog timeout has occurred

L/A Green: Shows the state of the physical link and activity on the link.
 A green LED indicates the state of the EtherCAT network:

LED	Link	Activity	Condition
ON	Yes	No	Port Open
Flickering	Yes	Yes	Port Open with activity
Off	No	(N/A)	Port Closed

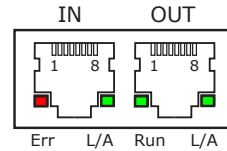

J4: EtherCAT PORTS
 RJ-45 receptacles,
 8 position, 4 signals

EtherCAT DEVICE ID (STATION ALIAS)

In an EtherCAT network, slaves are automatically assigned consecutive addresses based on their position on the network. But when the device must have a positive identification that is independent of cabling, a Device ID is used. In the BE2, this is provided by two 16-position rotary switches with hexadecimal encoding. These can set the Device ID of the drive from 0x00~0xFF (0~255 decimal). The chart shows the decimal values of the hex settings of each switch.

Example 1: Find the switch settings for decimal Device ID 107:

- Find the highest number in the x10 column that is less than 107 and set x10 to the hex value in the same row:
 $96 < 107$ and $112 > 107$, so $x10 = 96 = \text{Hex } 6$
- Subtract 96 from the desired Device ID to get the decimal value for the switch x1 and set it to the Hex value in the same row:
 $x1 = (107 - 96) = 11 = \text{Hex } B$
- Result: $X10 = 6$, $X1 = B$, Alias = $0x6B$ (107)

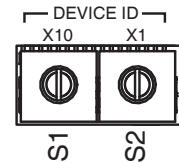

EtherCAT Device ID Switch Decimal values

Set	x10	x1	Set	x10	x1
Hex	Dec		Hex	Dec	
0	0	0	8	128	8
1	16	1	9	144	9
2	32	2	A	160	10
3	48	3	B	176	11
4	64	4	C	192	12
5	80	5	D	208	13
6	96	6	E	224	14
7	112	7	F	240	15

INDICATORS: DRIVE STATE

Two bi-color LEDs give the state of the BE2 drive. Colors do not alternate, and can be solid ON or blinking. When multiple conditions occur, only the top-most condition will be displayed. When that condition is cleared the next one below will shown.

- Red/Blinking = Latching fault. Operation will not resume until drive is Reset.
- Red/Solid = Transient fault condition. Drive will resume operation when the condition causing the fault is removed.
- Green/Double-Blinking = STO circuit active, drive outputs are Safe-Torque-Off
- Green/Slow-Blinking = Drive OK but NOT-enabled. Will run when enabled.
- Green/Fast-Blinking = Positive or Negative limit switch active. Drive will only move in direction not inhibited by limit switch.
- Green/Solid = Drive OK and enabled. Will run in response to reference inputs or EtherCAT commands.

Latching Faults

- Defaults
- Short circuit (Internal or external)
 - Drive over-temperature
 - Motor over-temperature
 - Feedback Error
 - Following Error
- Optional (programmable)
- Over-voltage
 - Under-voltage
 - Motor Phasing Error
 - Command Input Fault

AMP LEDS & DEVICE ID SWITCHES

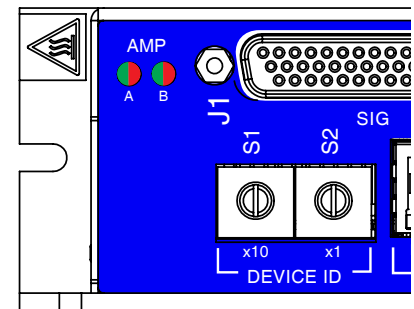

COMMUNICATIONS: RS-232 SERIAL

BE2 is configured via a three-wire, full-duplex DTE RS-232 port that operates from 9600 to 115,200 Baud, 8 bits, no parity, and one stop bit. Signal format is full-duplex, 3-wire, DTE using RxD, TxD, and Gnd. Connections to the BE2 RS-232 port are through J4, an RJ-11 connector. The BE2 Serial Cable Kit (SER-CK) contains a modular cable, and an adapter that connects to a 9-pin, Sub-D serial port connector (COM1, COM2, etc.) on PC's and compatibles.

After power-on, reset, or transmission of a Break character, the Baud rate will be 9,600. Once communication has been established at this speed, the Baud rate can be changed to a higher rate (19,200, 57,600, 115,200).

SER-CK SERIAL CABLE KIT

The SER-CK provides connectivity between a D-Sub 9 male connector and the RJ-11 connector on the BE2. It includes an adapter that plugs into the COM1 (or other) port of a PC and uses common modular cable to connect to the BE2. The connections are shown in the diagram below.

J5: RS-232 PORT

RJ-11 receptacle, 6 position, 4 contact

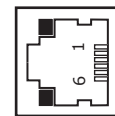
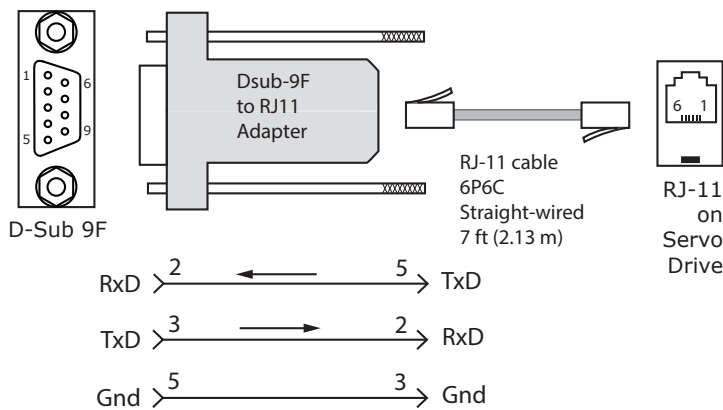

PIN	SIGNAL
2	RxD
3,4	* Gnd
5	TxD

* Signal Ground



Don't forget to order a Serial Cable Kit SER-CK when placing your order for a BE2!

USB TO RS-232 ADAPTERS

These may or may not have the speed to work at the 115,200 Baud rate which gives the best results with CME. Users have reported that adapters using the FTDI chipset work well with CME

ASCII COMMUNICATIONS

The Copley ASCII Interface is a set of ASCII format commands that can be used to operate and monitor these drives over an RS-232 serial connection. For instance, after basic drive configuration values have been programmed using CME, a control program can use the ASCII Interface to:

- Enable the drive in Programmed Position mode.
- Home the axis.
- Issue a series of move commands while monitoring position, velocity, and other run-time variables.

The Baud rate defaults to 9,600 after power-on or reset and is programmable up to 115,200 thereafter.

After power-on, reset, or transmission of a Break character, the Baud rate will be 9,600. Once communication has been established at this speed, the Baud rate can be changed to a higher rate (19,200, 57,600, 115,200).

ASCII parameter 0x90 holds the Baud rate data. To set the rate to 115,200 enter this line from a terminal:

```
s r0x90 115200 <enter>
```

Then, change the Baud rate in the computer/controller to the new number and communicate at that rate.

Additional information can be found in the ASCII Programmers Guide on the Copley website:

<http://www.copleycontrols.com> > Support > Manuals > ASCII Programmer's Guide

SAFE TORQUE OFF (STO)

The Safe Torque Off (STO) function is defined in IEC 61800-5-2. Two channels are provided which, when de-energized, prevent the upper and lower devices in the PWM outputs from being operated by the digital control core.

This provides a positive OFF capability that cannot be overridden by the control firmware, or associated hardware components. When the opto-couplers are energized (current is flowing in the input diodes), the control core will be able to control the on/off state of the PWM outputs.

INSTALLATION



Refer to the 16-01338 Accelnet & Stepnet Plus Panels STO Manual

The information provided in the 16-01338 Accelnet & Stepnet Plus Panels STO Manual must be considered for any application using the drive's STO feature.

FAILURE TO HEED THIS WARNING CAN CAUSE EQUIPMENT DAMAGE, INJURY, OR DEATH.



DANGER

STO BYPASS (MUTING)

In order for the PWM outputs of the BE2 to be activated, current must be flowing through all of the opto-couplers that are connected to the STO-IN1 and STO-IN2 terminals of J6, and the drive must be in an ENABLED state. When the opto-couplers are OFF, the drive is in a Safe Torque Off (STO) state and the PWM outputs cannot be activated by the control core to drive a motor.

This diagram shows connections that will energize all of the opto-couplers from an internal current-source. When this is done the STO feature is overridden and control of the output PWM stage is under control of the digital control core.

If not using the STO feature, these connections must be made in order for the BE2 to be enabled.

FUNCTIONAL DIAGRAM



Current must flow through all of the opto-couplers before the drive can be enabled

* STO bypass connections on the BE2 and Xenus XEL-XPL models are different. If both drives are installed in the same cabinet, the diode should be wired as shown to prevent damage that could occur if the STO bypass connectors are installed on the wrong drive. The diode is not required for STO bypass on the BE2 and can be replaced by a wire between pins 7 and 9.

STO BYPASS CONNECTIONS

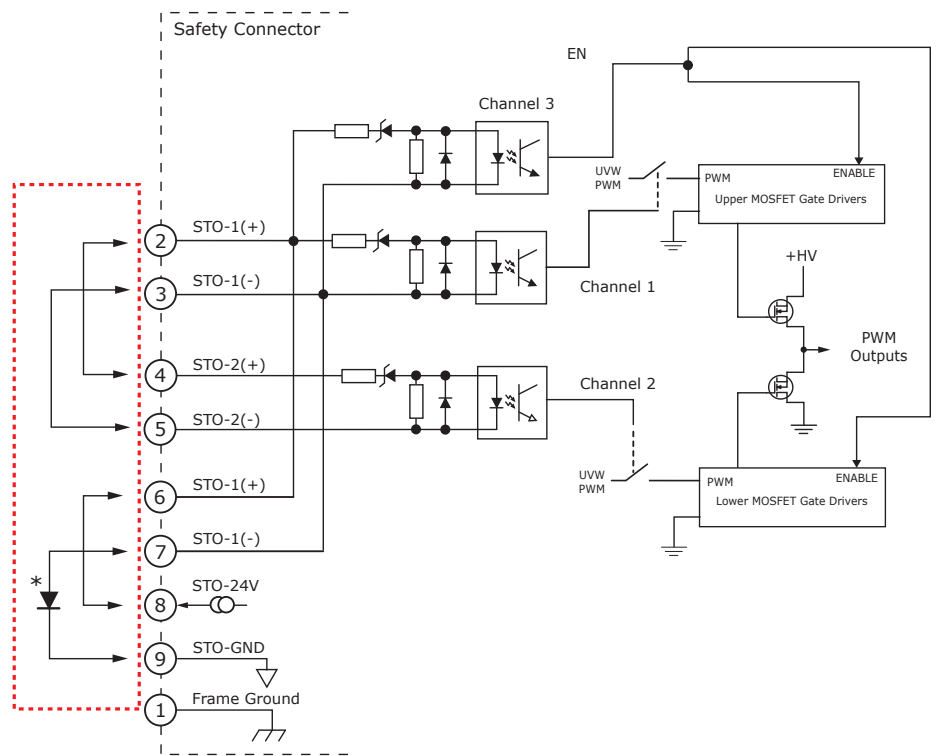

SAFETY CONNECTOR J6

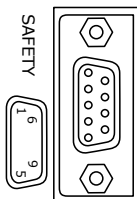

CONNECTIONS

PIN	SIGNAL	PIN	SIGNAL
1	Frame Gnd	6	STO-1(+)
2	STO-1(+)	7	STO-1(-)
3	STO-1(-)	8	STO-24V
4	STO-2(+)	9	STO-GND
5	STO-2(-)		

DIGITAL COMMAND INPUTS: POSITION

POSITION COMMAND INPUTS

Single-ended digital position commands must be sourced from devices with active pull-up and pull-down to take advantage of the high-speed inputs.

For differential commands, the A & B channels of the multi-mode encoder ports are used.

SINGLE-ENDED PULSE & DIRECTION

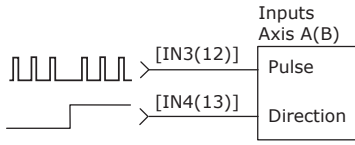

DIFFERENTIAL PULSE & DIRECTION

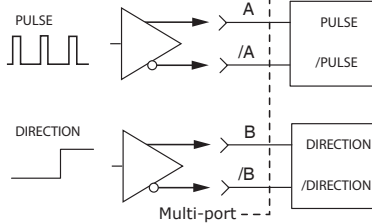

SINGLE-ENDED: IN3, 4, 12, 13

Signal	Axis A	Axis B
[IN3(12)] Pls, CU, Enc A	J1-9	J1-14
[IN4(13)] Dir, CD, Enc B	J1-10	J1-15
Signal Ground	J1-6,16,22,31,37,44	
Frame Ground	J1-1	

SINGLE-ENDED CU/CD

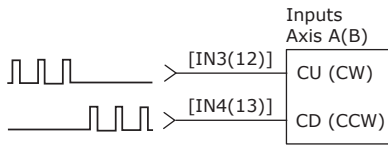

DIFFERENTIAL CU/CD

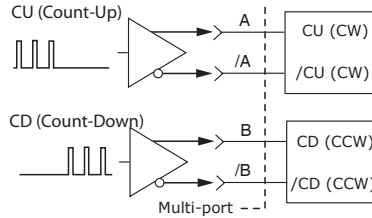

DIFFERENTIAL: MULTI-PORT A, /A, B, /B

Signal	Axis A	Axis B
[Enc A] Pls, CU, Enc A	J1-36	J1-42
[Enc /A] /Pls, /CU, Enc /A	J1-21	J1-27
[Enc B] Dir, CD, Enc B	J1-35	J1-41
[Enc /B] /Dir, /CD, Enc /B	J1-20	J1-26
Signal Ground	J1-6,16,22,31,37,44	
Frame Ground	J1-1	

QUAD A/B ENCODER SINGLE-ENDED

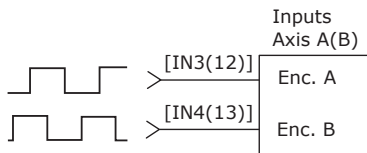

QUAD A/B ENCODER DIFFERENTIAL

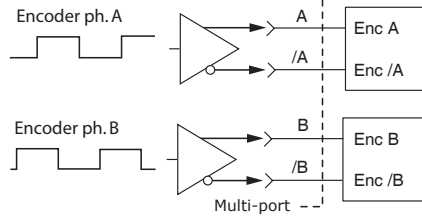

DIGITAL COMMAND INPUTS: VELOCITY, TORQUE

Single-ended digital torque or velocity commands must be sourced from devices with active pull-up and pull-down to take advantage of the high-speed inputs.

For differential commands, the A & B channels of the multi-mode encoder ports are used.

SINGLE-ENDED PWM & DIRECTION

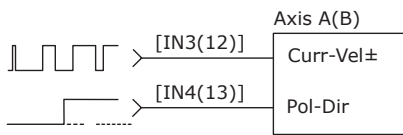

DIFFERENTIAL PWM & DIRECTION

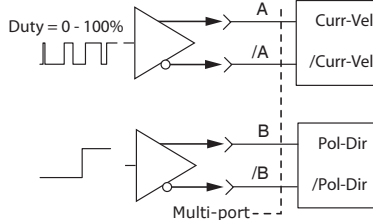

SINGLE-ENDED: IN3, 4, 12, 13

Signal	Axis A	Axis B
[IN3(12)] Curr-Vel±	J1-9	J1-14
[IN4(13)] / Curr-Vel±	J1-10	J1-15
Signal Ground	J1-6,16,22,31,37,44	
Frame Ground	J1-1	

SINGLE-ENDED 50% PWM

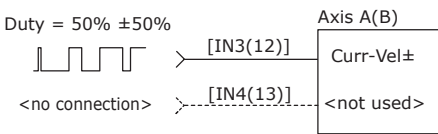

DIFFERENTIAL 50% PWM

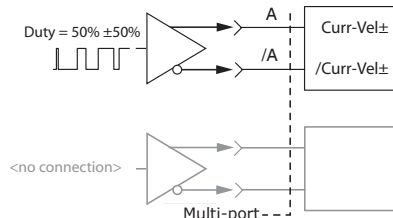

DIFFERENTIAL: MULTI-PORT A, /A, B, /B

Signal	Axis A	Axis B
[Enc A] Curr-Vel±	J1-36	J1-42
[Enc /A] /Curr-Vel±	J1-21	J1-27
[Enc B] Pol-Dir	J1-35	J1-41
[Enc /B] /Pol-Dir	J1-20	J1-26
Signal Ground	J1-6,16,22,31,37,44	
Frame Ground	J1-1	

MULTI-MODE PORT AS AN INPUT

INPUT TYPES

POSITION COMMAND INPUTS: DIFFERENTIAL

- Pulse & Direction
- CW & CCW (Clockwise & Counter-Clockwise)
- Encoder Quad A & B
- Camming Encoder A & B input

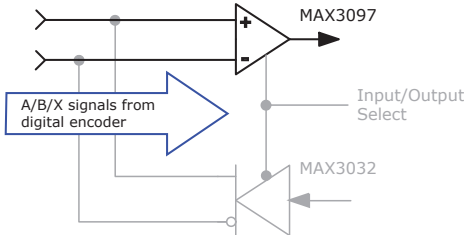

CURRENT or VELOCITY COMMAND INPUTS: DIFFERENTIAL

- Current or Velocity & Direction
- Current or Velocity (+) & Current or Velocity (-)

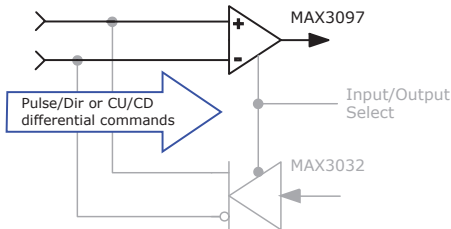

SECONDARY FEEDBACK: INCREMENTAL

- Quad A/B/X incremental encoder

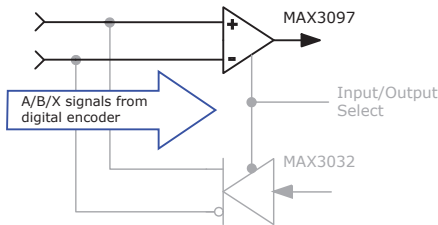

SECONDARY FEEDBACK: ABSOLUTE

- S channel: Absolute A encoders (2-wire)
The S channel first sends a Clock signal and then receives Data from the encoder in half-duplex mode.
- S & X channels: SSI, BiSS, EnDat encoders (4-wire)
The X channel sends the Clock signal to the encoder, which initiates data transmission from the encoder on the S-channel in full-duplex mode

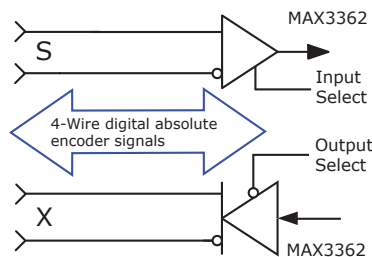
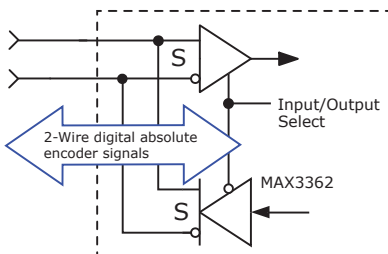

SIGNALS & PINS

Signal	Axis A J1	Axis B J1
Pulse, CW, Encoder A	36	42
/Pulse, /CW, Encoder /A	21	27
Direction, CCW, Encoder B	35	41
/Direction, /CCW, Encoder /B	20	26
Quad Enc X, Absolute Clock	34	40
Quad Enc /X, /Absolute Clock	19	25
Enc S, Absolute (Clock) Data	33	39
Enc /S, / Absolute (Clock) Data	18	24
Signal Ground	6, 16, 22, 31, 37, 44	
Frame Ground	1	

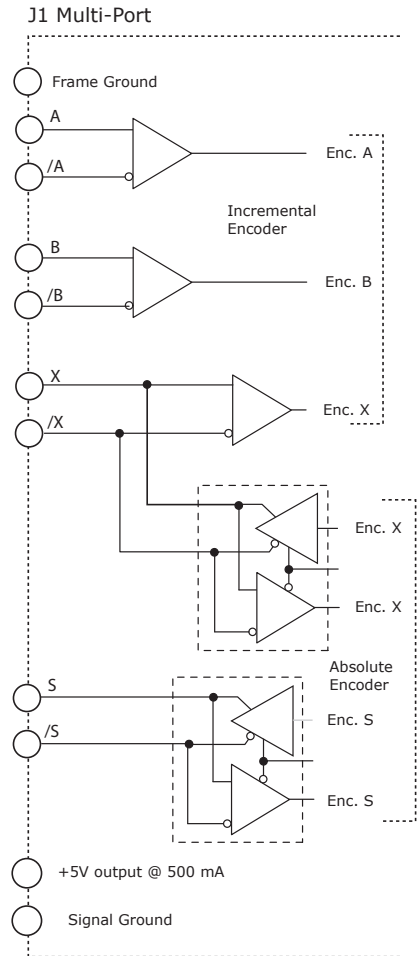

MULTI-MODE PORT AS AN OUTPUT

OUTPUT TYPES

BUFFERED FEEDBACK OUTPUTS: DIFFERENTIAL

- Encoder Quad A, B, X channels
- Direct hardware connection between quad A/B/X encoder feedback and differential line drivers for A/B/X outputs

EMULATED FEEDBACK OUTPUTS: DIFFERENTIAL

Firmware produces emulated quad A/B signals from feedback data from the following devices:

- Absolute encoders
- Resolvers (-R option)
- Analog Sin/Cos incremental encoders

SIGNALS & PINS

Signal	Axis A J1	Axis B J1
Encoder A	36	42
Encoder /A	21	27
Encoder B	35	41
Encoder /B	20	26
Encoder X	34	40
Encoder /X	19	25
Encoder S	33	39
Encoder /S	18	24
Signal Ground	6, 16, 22, 31, 37, 44	
Frame Ground	1	

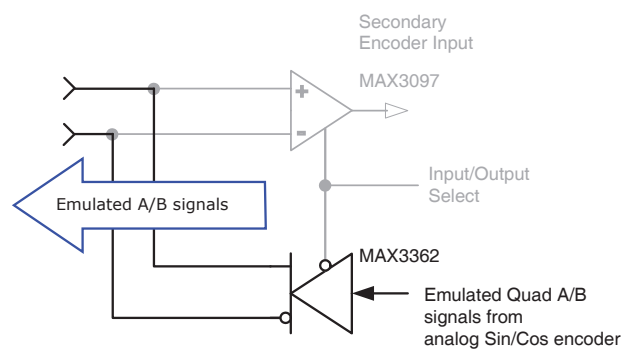
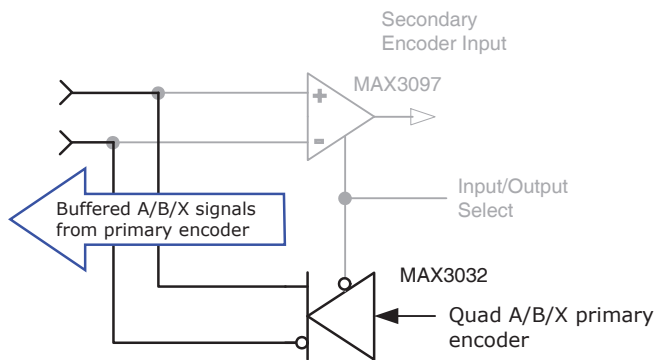
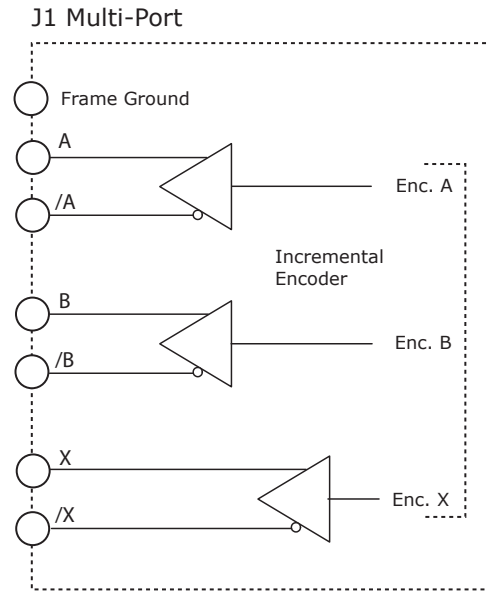

HIGH SPEED INPUTS: IN1, IN2, IN10, IN11

- Digital, non-isolated, high-speed
- Programmable pull-up/pull-down
- 24V Compatible
- Programmable functions

SPECIFICATIONS

Input	Data	Notes
Input Voltages	HI	$V_{T+} \geq 3.5 \text{ Vdc}$
	LO	$V_{T-} \leq 1.0 \text{ Vdc}$
	VH^1	$VH \leq \pm 1.5 \text{ Vdc}$
	Max	+30 Vdc
	Min	0 Vdc
Pull-up/down	R1	15 k Ω
Low pass filter	R2	15 k Ω
	C1	100 pF
Input Current	24V	1.3 mA _{dc}
	0V	-0.33 mA _{dc}
Time constant	RC ²	1.5 μ s

CONNECTIONS

Input	Pin
IN1	J1-7
IN2	J1-8
IN10	J1-12
IN11	J1-13
Sgnd	J1-6, 16, 22, 31, 37, 44

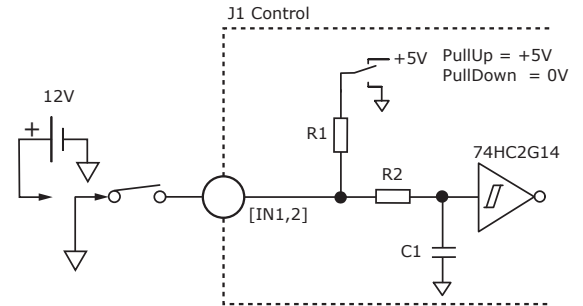

Notes:

- 1) VH is hysteresis voltage (V_{T+}) - (V_{T-})
- 2) The $R2 \cdot C2$ time constant applies when input is driven by active HI/LO devices

SINGLE-ENDED/DIFFERENTIAL INPUTS: IN3, IN4, IN12, IN13

- Digital, non-isolated, high-speed
- Programmable pull-up/pull-down
- 12V Compatible
- Single-ended or Differential
- Programmable functions

SPECIFICATIONS

Input	Data	Notes
Input Voltages Single-ended	HI	$V_{in} \geq 2.7 \text{ Vdc}$
	LO	$V_{in} \leq 2.3 \text{ Vdc}$
	VH^1	45 mVdc typ
Input Voltages Differential ³	HI	$V_{diff} \geq +200 \text{ mVdc}$
	LO	$V_{diff} \leq -200 \text{ mVdc}$
	VH	$\pm 45 \text{ mVdc typ}$
Common mode	V_{cm}	0 to +12 Vdc
Pull-up/down	R1	10 k Ω
Low pass filter	R2	1 k Ω
	C1	100 pF
Time constant	RC ²	100 ns

CONNECTIONS

S.E.	DIFF	Pin
IN3	IN3+	J1-9
IN4	IN3-	J1-10
IN12	IN12+	J1-14
IN13	IN12-	J1-15
Sgnd		J1-6, 16, 22, 31, 37, 44

Notes:

- 1) VH is hysteresis voltage IN2 - IN3 or IN12 - IN13
- 2) The $R2 \cdot C2$ time constant applies when input is driven by active HI/LO devices
- 3) $V_{diff} = AINn(+)$ - $AINn(-)$
n = 1 for Axis A, 2 for Axis B

SINGLE-ENDED

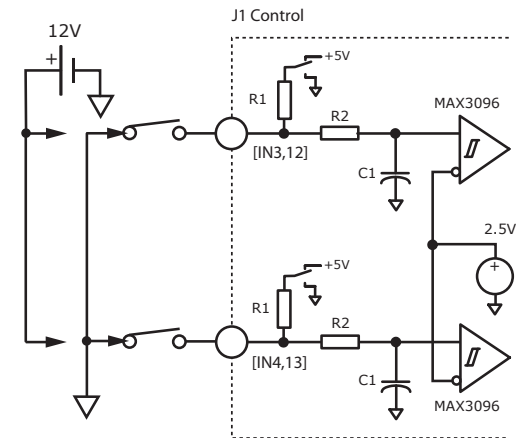

DIFFERENTIAL

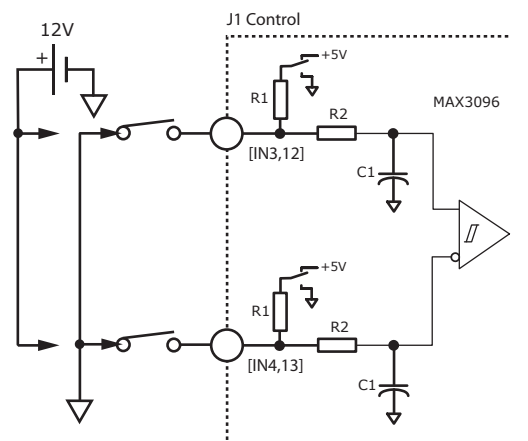

MOTOR OVERTEMP INPUTS: IN9, IN18

- Digital, non-isolated
- Motor overtemp inputs
- 12V Compatible
- Programmable functions

SPECIFICATIONS

Input	Data	Notes
Input Voltages	HI	$V_{in} \geq 3.5 \text{ Vdc}$
	LO	$V_{in} \leq 0.7 \text{ Vdc}$
	Max	+12 Vdc
	Min	0 Vdc
Pull-up/down	R1	4.99 k Ω
Input Current	12V	1.4 mA _{dc}
	0V	-1.0 mA _{dc}
Low pass filter	R2	10 k Ω
	C1	33 nF
Time constant	Te	330 μs *

* RC time constant applies when inputs are driven by active high/low devices

CONNECTIONS

Input	Pin
IN9	J7-7
IN18	J8-7
Sgnd	J7,8-5, 16, 25, 26

MOTOR OVER TEMP INPUT

The 4.99k pull-up resistor works with PTC (positive temperature coefficient) thermistors that conform to BS 4999:Part 111:1987, or switches that open/close indicating a motor over-temperature condition. The active level is programmable.

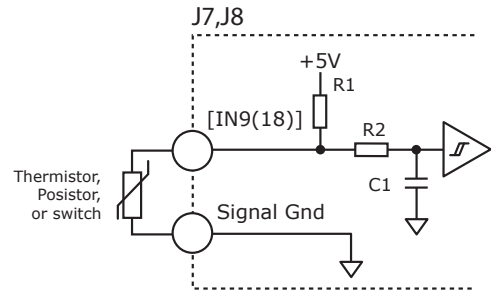

BS 4999:PART 111:1987

Property	Ohms
Resistance in the temperature range 20°C to +70°C	60~750
Resistance at 85°C	≤1650
Resistance at 95°C	≥3990
Resistance at 105°C	≥12000

OPTO-ISOLATED INPUTS: IN5, IN6, IN7, IN8, IN14, IN15, IN16, IN17

- Digital, opto-isolated
- 2 Groups of four, each with own Common terminal
- Works with current sourcing or sinking drivers
- 24V Compatible
- Programmable functions

SPECIFICATIONS

Input	Data	Notes
Input Voltages	HI	$V_{in} \geq \pm 10.0 \text{ Vdc}$ *
	LO	$V_{in} \leq \pm 6 \text{ Vdc}$ *
	Max	$\pm 30 \text{ Vdc}$ *
Input Current	$\pm 24\text{V}$	$\pm 3.6 \text{ mA}_{dc}$
	0V	0 mA _{dc}

* Vdc Referenced to ICOM terminals.

CONNECTIONS

Signal	Pins	Signal	Pins
IN5	J2-2	IN14	J2-7
IN6	J2-3	IN15	J2-8
IN7	J2-4	IN16	J2-9
IN8	J2-5	IN17	J2-18
ICOM1	J2-6	ICOM2	J2-17

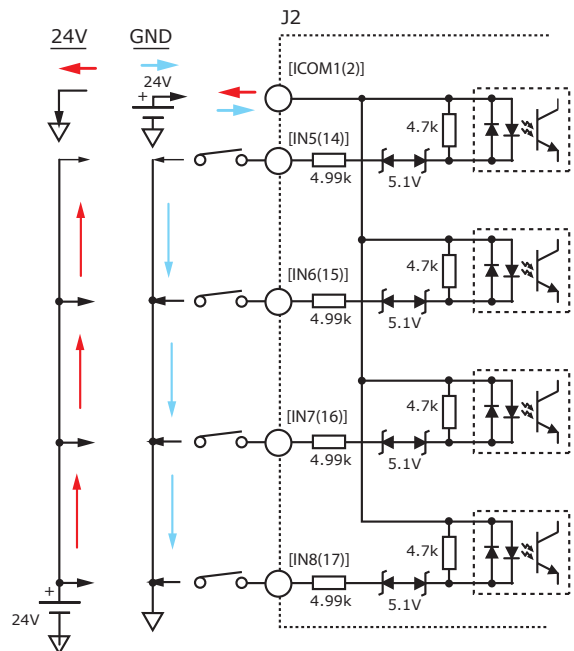

ANALOG INPUTS: AIN1, AIN2

- ±10 Vdc, differential
- 12-bit resolution
- Programmable functions

The analog inputs have a ±10 Vdc range at 12-bit resolution. As reference inputs they can take position/velocity/torque commands from a controller. If not used as command inputs, they can be used as general-purpose analog inputs.

SPECIFICATIONS

Spec	Data	Notes
Input Voltage	Vref	±10 Vdc
Input Resistance	Rin	5.05 kΩ

CONNECTIONS

Signal	Pins	
	Axis A	Axis B
AIN(+)	J1-3	J1-5
AIN(-)	J1-2	J1-4
Sgnd	J1-6, 16, 22, 31, 37, 44	

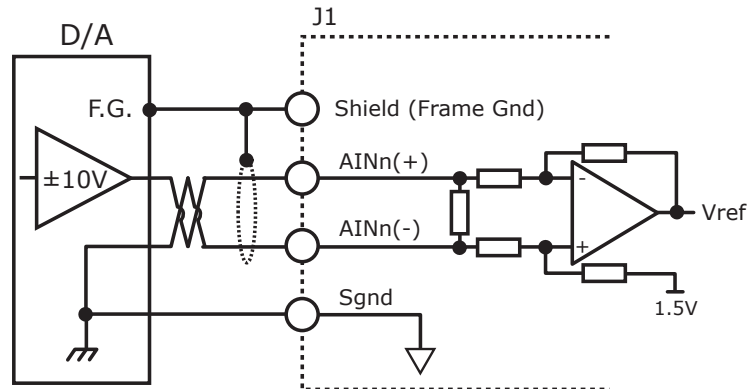

OPTO-ISOLATED OUTPUTS: OUT1, OUT2, OUT3, OUT4, OUT5

- Digital, opto-isolated
- MOSFET output SSR, 2-terminal
- Flyback diodes for inductive loads
- 24V Compatible
- Programmable functions

SPECIFICATIONS

Output	Data	Notes
ON Voltage OUT(+) - OUT(-)	Vdc	0.85V @ 300 mA _{dc}
Output Current	I _{out}	300 mA _{dc} max

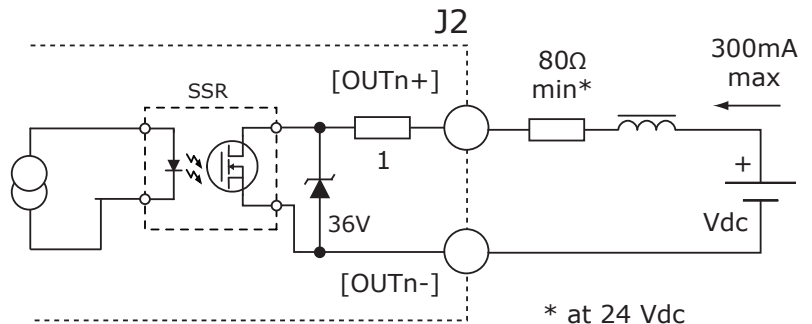

HI/LO DEFINITIONS: OUTPUTS

Input	State	Condition
OUT1~5	HI	Output SSR is ON, current flows
	LO	Output SSR is OFF, no current flows

CONNECTIONS

Signal	(+)	(-)
OUT1	J2-19	J2-10
OUT2	J2-20	J2-11
OUT3	J2-21	J2-12
OUT4	J2-22	J2-13
OUT5	J2-23	J2-14

OPTO-ISOLATED MOTOR BRAKE OUTPUTS: OUT6, OUT7

- Brake outputs
- Opto-isolated
- Flyback diodes for inductive loads
- 24V Compatible
- Connection for external 24V power supply
- Programmable functions

SPECIFICATIONS

Output	Data	Notes
Voltage Range	Max	+30 Vdc
Output Current	Ids	1.0 Adc

HI/LO DEFINITIONS: OUTPUTS

Input	State	Condition
BRK-A,B OUT6,7	HI	Output transistor is OFF Brake is un-powered and locks motor Motor cannot move Brake state is Active
	LO	Output transistor is ON Brake is powered, releasing motor Motor is free to move Brake state is NOT-Active

CME Default Setting for Brake Outputs [OUT6,7] is "Brake - Active HI"

Active = Brake is holding motor shaft (i.e. the *Brake is Active*)
Motor cannot move

No current flows in coil of brake
CME I/O Line States shows Output 6 or 7 as HI
BRK Output voltage is HI (24V), MOSFET is OFF
Servo drive output current is zero
Servo drive is disabled, PWM outputs are off

Inactive = Brake is not holding motor shaft (i.e. the *Brake is Inactive*)
Motor can move

Current flows in coil of brake
CME I/O Line States shows Output 6 or 7 as LO
BRK output voltage is LO (~0V), MOSFET is ON
Servo drive is enabled, PWM outputs are on
Servo drive output current is flowing

*

There should be only one conductor in each position of the J3 connector. If brakes are to be wired directly to J3 for their 24V power, use a double wire ferrule for J3-4. Information for ferrules can be found on page 27.

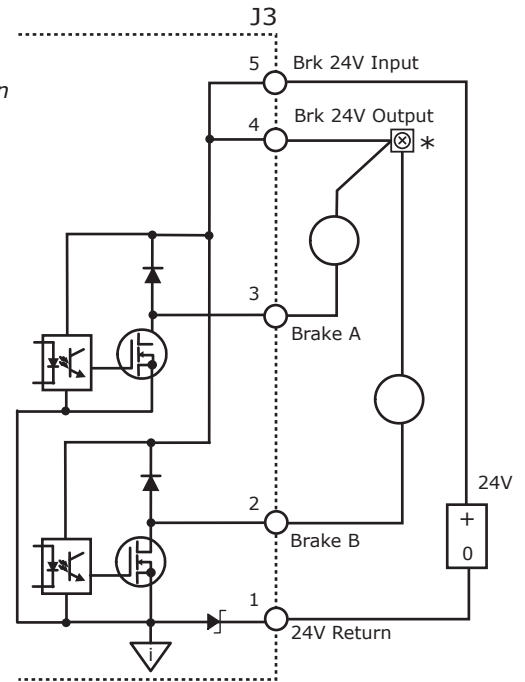

The brake circuits are optically isolated from all drive circuits and frame ground.

CONNECTIONS

Pin	Signal
5	Brk 24V Input
4	Brk 24V Output
3	Brake A [OUT6]
2	Brake B [OUT7]
1	24V Return

This diagram shows the connections to the drive that share a common ground in the driver. If the brake 24V power supply is separate from the DC supply powering the drive, it is important that it connects to an earth or common grounding point with the HV power supply.

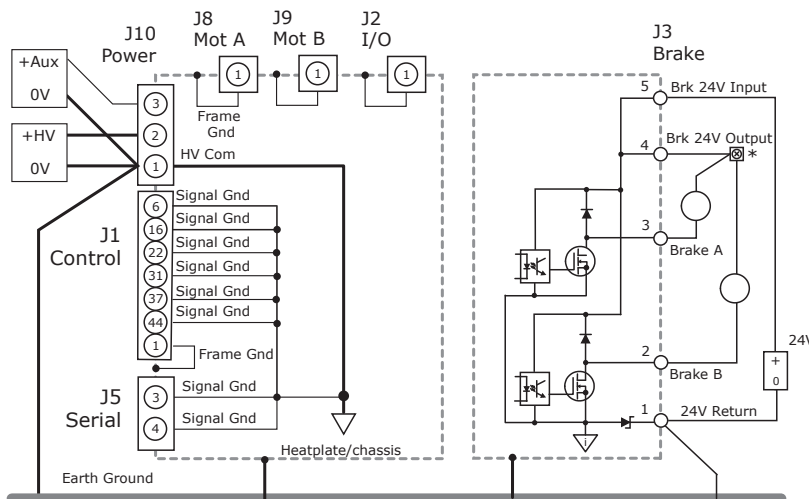

Earthing connections for power supplies should be as close as possible to eliminate potential differences between power supply 0V terminals.

FEEDBACK CONNECTIONS

QUAD A/B/X ENCODER WITH SIGNAL LOSS DETECTION

Encoders with differential line-driver outputs are required (single-ended encoders are not supported) and provide incremental position feedback via the A/B signals and the optional index signal (X) gives a once per revolution position mark. The MAX3097 receiver has differential inputs with fault protections for the following conditions:

Condition	Example
Line-line shorts	A shorted to /A
Open-circuits:	A disconnected, /A connected. Terminator resistor pulls A & /A together for a short-circuit fault
Low-voltage	$V_a - V_b \leq 200 \text{ mV}$, or $\geq -200 \text{ mV}$ Encoder power loss, cabling, etc.

QUAD ENCODER WITH INDEX

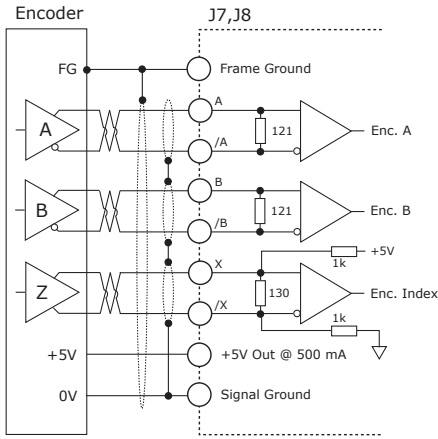

A/B/X SIGNALS

Signal	J7,J8 Pin
Enc A	13
Enc /A	12
Enc B	11
Enc /B	10
Enc X	9
Enc /X	8
+5V	6, 17
Sgnd	5, 16, 25, 26
F.G.	1

Sgnd = Signal Ground
F.G. = Frame Gnd

SIGNAL LOSS DETECTION LOGIC

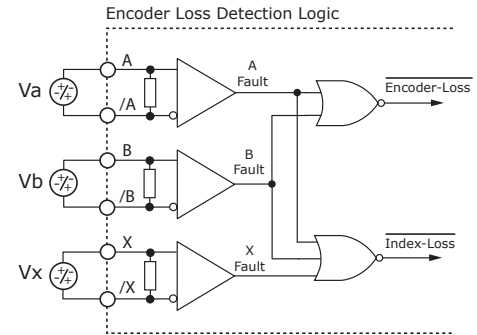

ANALOG SIN/COS INCREMENTAL ENCODER

The sin/cos inputs are analog differential with 121 Ω terminating resistors and accept 1 Vp-p signals in the format used by incremental encoders with analog outputs, or with *ServoTube* motors. The index input is digital, differential.

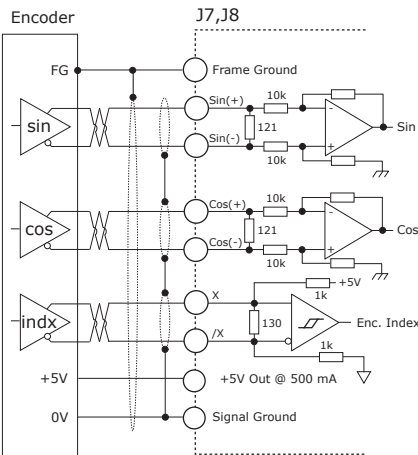

SIN/COS SIGNALS

Signal	J7,J8 Pin
Sin(+)	19
Sin(-)	18
Cos(+)	21
Cos(-)	20
X	9
/X	8
+5V	6, 17
Sgnd	5, 16, 25, 26
F.G.	1

Sgnd = Signal Ground
F.G. = Frame Gnd

RESOLVER (-R OPTION)

Connections to the resolver should be made with double-shielded cable that uses three twisted-pairs plus an outer shield. Once connected, resolver set up, motor phasing, and other commissioning adjustments are made with CME software. There are no hardware adjustments.

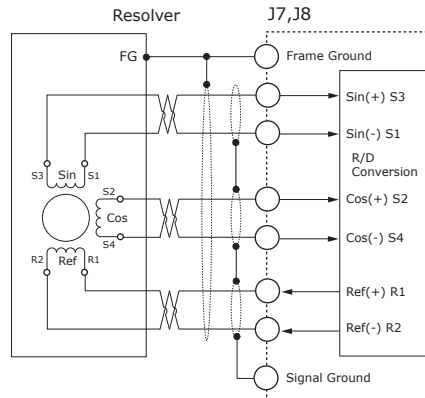

RESOLVER SIGNALS

Signal	J7,J8 Pin
Sin(+)	S3 19
Sin(-)	S1 18
Cos(+)	S2 21
Cos(-)	S4 20
Ref(+)	R1 23
Ref(-)	R2 22
Sgnd	5,16 25, 26
F.G.	1

Sgnd = Signal Ground
F.G. = Frame Gnd

FEEDBACK CONNECTIONS

SSI ABSOLUTE ENCODER

The SSI (Synchronous Serial Interface) is an interface used to connect an absolute position encoder to a motion controller or control system. The XEL drive provides a train of clock signals in differential format to the encoder which initiates the transmission of the position data on the subsequent clock pulses. The polling of the encoder data occurs at the current loop frequency (16 kHz). The number of encoder data bits and counts per motor revolution are programmable.

The hardware bus consists of two signals: SCLK and SDATA. Data is sent in 8 bit bytes, LSB first. The SCLK signal is only active during transfers. Data is clocked out on the falling edge and clock in on the rising edge of the Master.

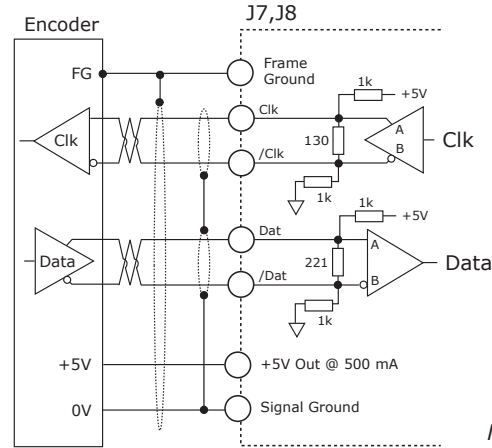

SSI, BiSS SIGNALS

SSI	BiSS	J7, J8 Pin
Clk	MA+	9
/Clk	MA-	8
Data	SL+	15
/Data	SL-	14
+5V		6, 17
Signal Ground		5, 16, 25, 26
Frame Gnd		1

Note: Single (outer) shields should be connected at both ends (motor and drive frame grounds). Inner shields should only be connected to Signal Ground on the drive.

BiSS ABSOLUTE ENCODER

BiSS is an - Open Source - digital interface for sensors and actuators. BiSS refers to principles of well known industrial standards for Serial Synchronous Interfaces like SSI, AS-Interface® and Interbus® with additional options.

- Serial Synchronous Data Communication
- Cyclic at high speed
- 2 unidirectional lines Clock and Data
- Line delay compensation for high speed data transfer
- Request for data generation at slaves
- Safety capable: CRC, Errors, Warnings
- Bus capability incl. actuators
- Bidirectional
- BiSS B-protocol: Mode choice at each cycle start
- BiSS C-protocol: Continuous mode

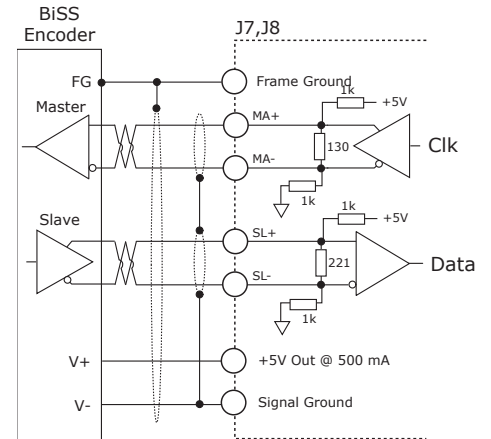

ENDAT ABSOLUTE ENCODER

The EnDat interface is a Heidenhain interface that is similar to SSI in the use of clock and data signals, but which also supports analog sin/cos channels from the same encoder. The number of position data bits is programmable as is the use of sin/cos channels. Use of sin/cos incremental signals is optional in the EnDat specification.

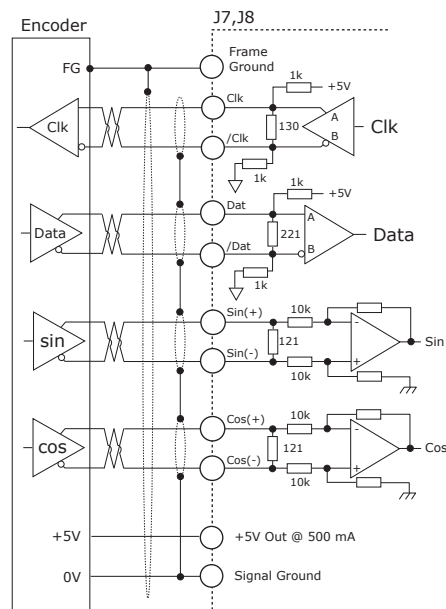

ENDAT SIGNALS

Signal	J7, J8 Pin
Clk	9
/Clk	8
Data	15
/Data	14
Sin(+)	19
Sin(-)	18
Cos(+)	21
Cos(-)	20
+5V	6, 17
Sgnd	5, 16, 25, 26
F.G.	1

Sgnd = Signal Ground
F.G. = Frame Gnd

ABSOLUTE-A ENCODER

The Absolute A interface is a serial, half-duplex type that is electrically the same as RS-485. Note the battery which must be connected. Without it, the encoder will produce a fault condition.

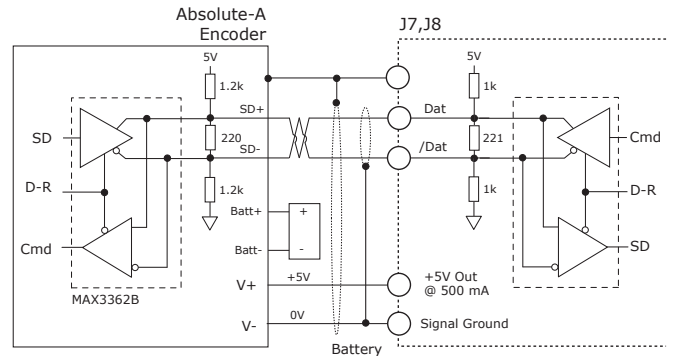

ABSOLUTE-A SIGNALS

Signal	J7, J8 Pin
Data	15
/Data	14
+5V	6, 17
Sgnd	5, 16, 25, 26
F.G.	1

Sgnd = Signal Ground
F.G. = Frame Gnd

MOTOR CONNECTIONS

MOTOR PHASE CONNECTIONS

The drive outputs are three-phase PWM inverters that convert the DC buss voltage (+HV) into three sinusoidal voltage waveforms that drive the motor phase-coils. Cable should be sized for the continuous current rating of the motor. Motor cabling should use twisted, shielded conductors for CE compliance, and to minimize PWM noise coupling into other circuits. Further details on motor connections can be found on page 24.

MOTOR SIGNALS

Signal	J9,J10 Pin
Mot U	4
Mot V	3
Mot W	2
Frame Gnd	1

* MOT W not used for DC brush motors

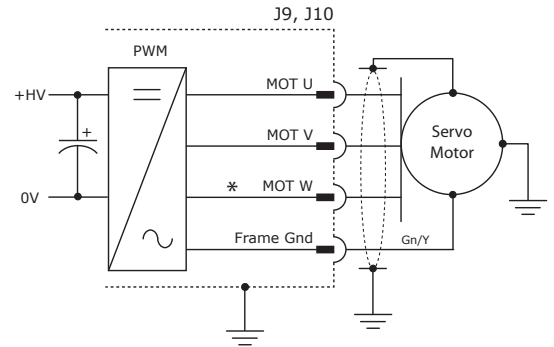

DIGITAL HALL SIGNALS

Hall signals are single-ended signals that provide absolute feedback within one electrical cycle of the motor. There are three of them (U, V, & W) and they may be sourced by magnetic sensors in the motor, or by encoders that have Hall tracks as part of the encoder disc. They typically operate at much lower frequencies than the motor encoder signals, and are used for commutation-initialization after startup, and for checking the motor phasing after the drive has switched to sinusoidal commutation.

HALL SIGNALS

Signal	J7,J8 Pin
Hall U	2
Hall V	3
Hall W	4
+5V	6, 17
Sgnd	5, 16, 25, 26
Frame Gnd	1

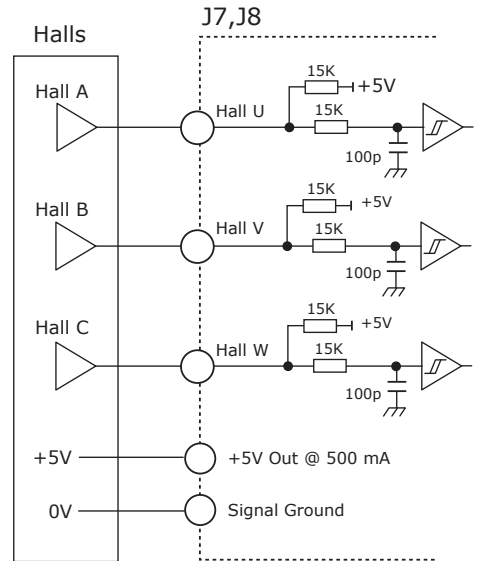

MOTOR OVER TEMP INPUT

The 4.99k resistor works with PTC (positive temperature coefficient) thermistors that conform to BS 4999:Part 111:1987 (table below), or switches that open/close indicating a motor over-temperature condition. The active level is programmable. These inputs are programmable for other functions if not used as Motemp inputs. And, other inputs are programmable for the Motemp function.

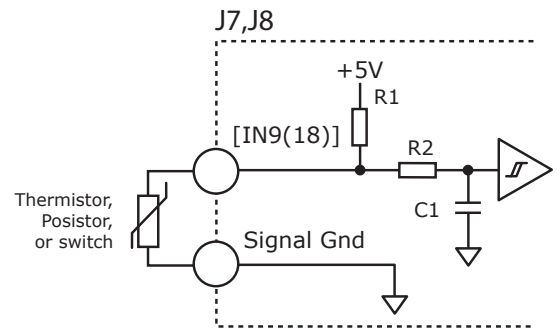

MOTEMP SIGNALS

Signal	Pin
Motemp A	J7-7
Motemp B	J8-7
J7,J8 Signal Ground	5,10
Frame Gnd	12

BS 4999 SENSOR

Property	Ohms
Resistance in the temperature range 20°C to +70°C	60~750
Resistance at 85°C	≤1650
Resistance at 95°C	≥3990
Resistance at 105°C	≥12000

MOTOR CONNECTIONS: DIGITAL QUAD A/B ENCODER

The connections shown may not be used in all installations

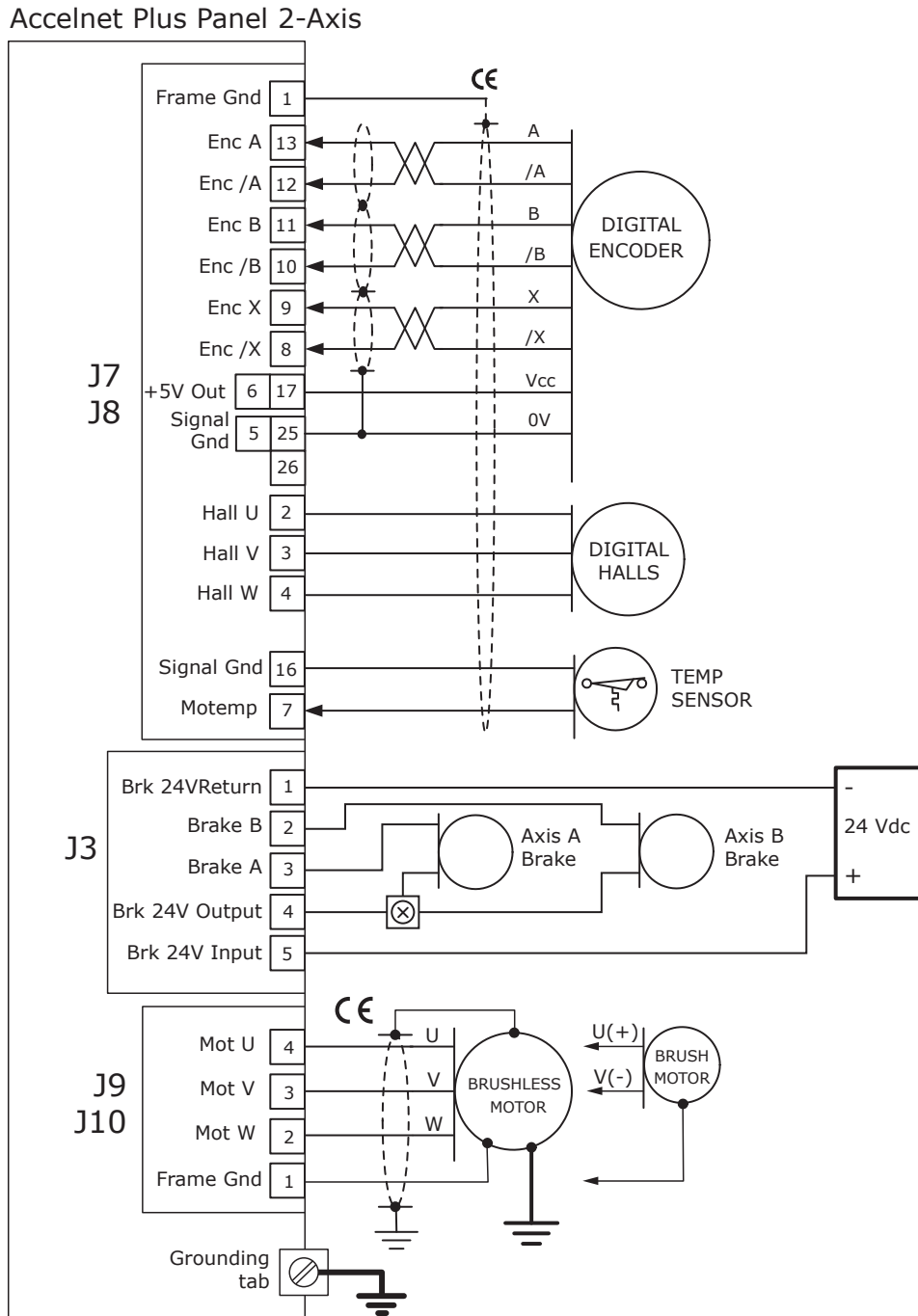

NOTES:

- 1) The +5VOut1 on J1-17,32 and J7-6, 17 is rated for 500 mA
The +5VOut2 on J1-23,38 and J8-6, 17 is rated for 500 mA
These are two independent power supplies, each with a 500 mA max output from all pins
- 2) CE symbols indicate connections required for CE compliance.

MOTOR CONNECTIONS: ANALOG SIN/COS ENCODER

The connections shown may not be used in all installations

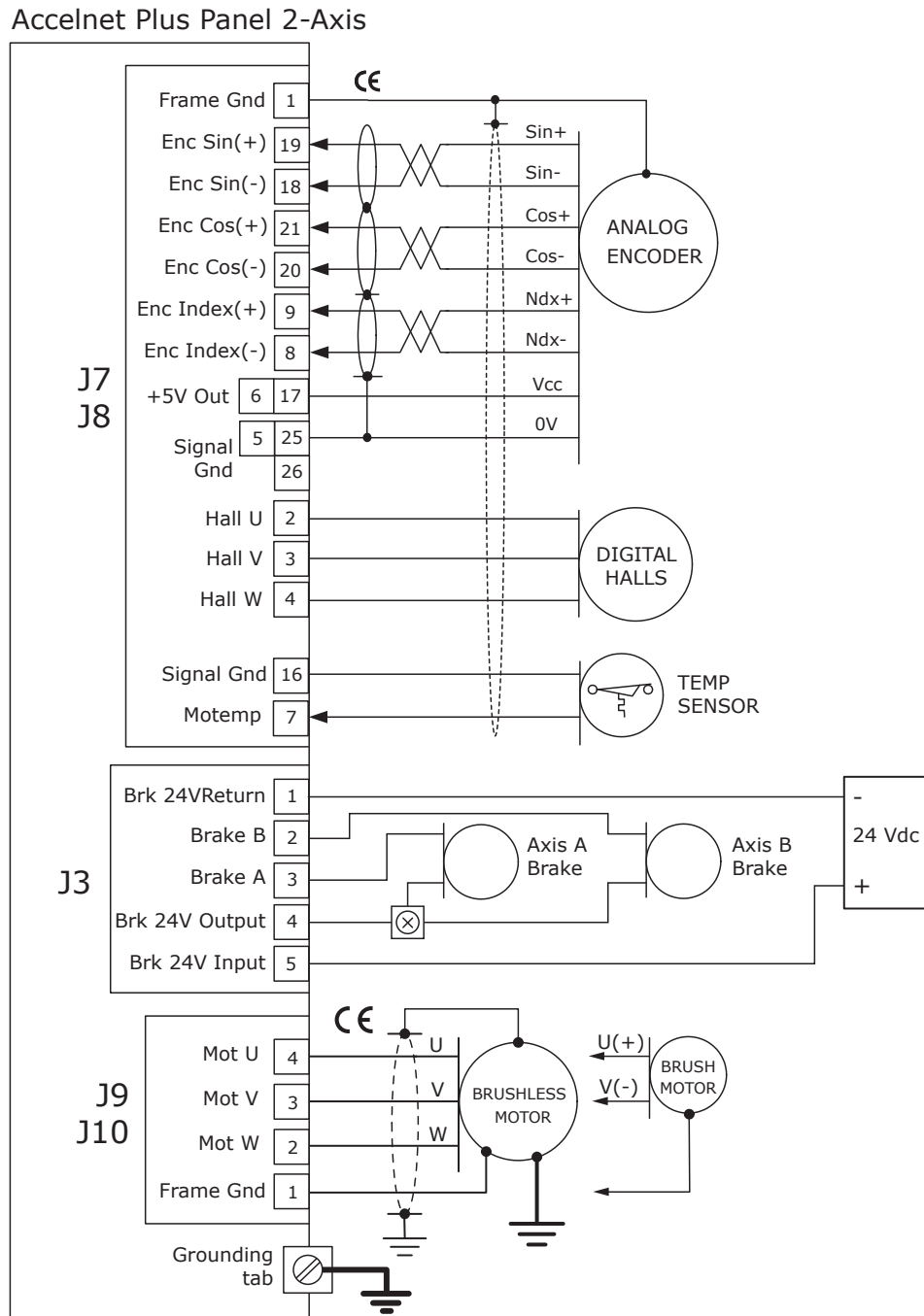

NOTES:

- 1) The +5VOut1 on J1-17,32 and J7-6, 17 is rated for 500 mA
The +5VOut2 on J1-23,38 and J8-6, 17 is rated for 500 mA
These are two independent power supplies, each with a 500 mA max output from all pins
- 2) CE symbols indicate connections required for CE compliance.

MOTOR CONNECTIONS: RESOLVERS (-R OPTION)

The connections shown may not be used in all installations.
Hall signals are not generally used with resolver feedback but are shown here because they function if needed for resolver operation.

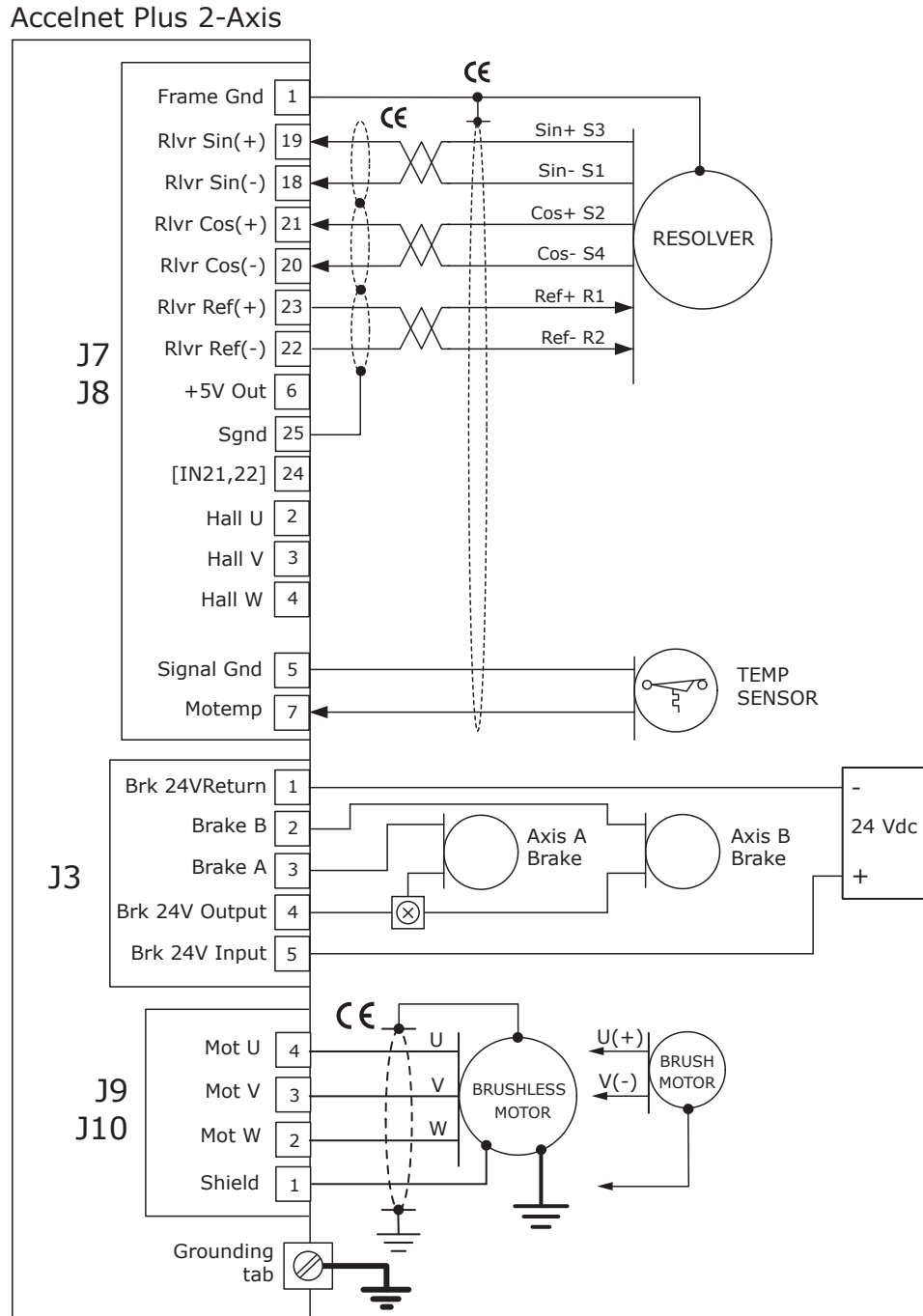

NOTES:

- 1) The +5VOut1 on J1-17,32 and J7-6, 17 is rated for 500 mA
The +5VOut2 on J1-23,38 and J8-6, 17 is rated for 500 mA
These are two independent power supplies, each with a 500 mA max output from all pins
- 2) CE symbols indicate connections required for CE compliance.

DEVICE STRUCTURE & ISOLATION

This graphic shows the electrical structure of the drive, detailing the elements that share a common circuit common (Signal Ground, HV Com) and circuits that are isolated and have no connection to internal circuits. Note that there is no connection between the heatplate (Chassis, Frame Ground) and any drive circuits.

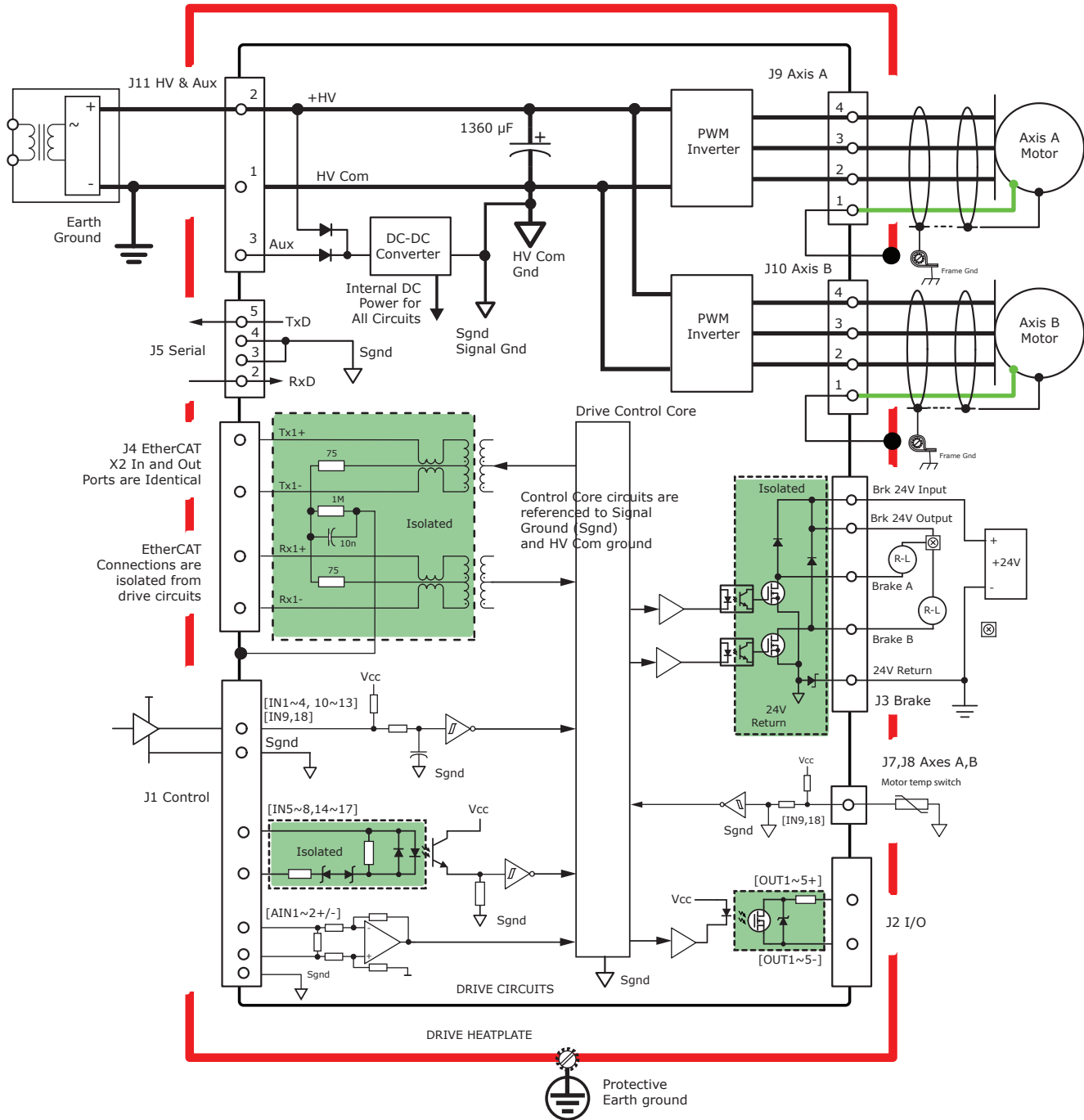

POWER & GROUNDING CONNECTIONS

DC POWER CONNECTIONS

- DC power must be provided by transformers that are galvanically isolated and provide reinforced insulation from the mains. *Auto-transformers cannot be used.*
- The (-) terminal of the power supply is not grounded at the power supply. It is grounded near each drive.
- Cabling to multiple drives for the +HV and 0V is best done in a "star" configuration, and not a "daisy-chain".
- The 0V, or return terminal of the DC power should be connected to frame ground near the drive power connector. From that point, a short wire can connect to the drive HV Ground.
- Cabling to the drive +HV and 0V terminals must be sized to carry the expected continuous current of the drive in the user's installation.
- DC power cabling should be shielded, twisted-pair for best EMI reduction. The shield should connect to the power supply frame ground on one end, and to the drive frame ground on the other. Adding a pigtail and ring-lug, as short as possible will provide a good connection of the shield at the drive.
- Motor cabling typically includes a green/yellow conductor for protective bonding of the motor frame. Connect as shown in the Motor Connections diagram on the following page.
- Motor cable conductors should be twisted and shielded for best EMI suppression.
- If a green/yellow grounding wire connects the motor to the drive's PE terminal, the shield pigtail and ring-lug may connect to one of the screws that mount the drive to the panel. A P-clip to ground the shield as near as possible to the drive will increase the EMI suppression of the shield. On the motor-end, the shield frequently connects to the connector shell. If the motor cable is a flying-lead from the motor, the shield may be connected to the motor frame internally.
- Braided cable shields are more effective for EMI reduction than foil shields. Double-shielded cables typically have a braided outer shield and foil shields for the internal twisted pairs. This combination is effective for both EMI reduction and signal quality of the feedback signals from analog encoders or resolvers.
- Motor cable shielding is not intended to be a protective bonding conductor unless otherwise specified by the motor manufacturer.
- For feedback cables, double-shielded cable with a single outer shield and individual shielded twisted pair internal shields gives the best results with resolvers, or analog sin/cos encoders.
- In double-shielded cables, the internal shielding should connect to the drive's Signal Ground on one end, and should be unconnected on the motor end.
- Single-shield feedback cables connect to the drive frame on one end, and to the motor frame on the other. Depending on the construction of the motor, leaving the feedback cable shield disconnected on the motor but connected on the drive end may give better results.
- The drive should be secured to the equipment frame or panels using the mounting slots. This ensures a good electrical connection for optimal EMI performance. The drive chassis is electrically conductive.

DC POWER WIRING

P-clips secure cables to a panel and provide full contact to the cable shields after the insulation has been stripped. This should be done as close to the drive as possible for best EMI attenuation.

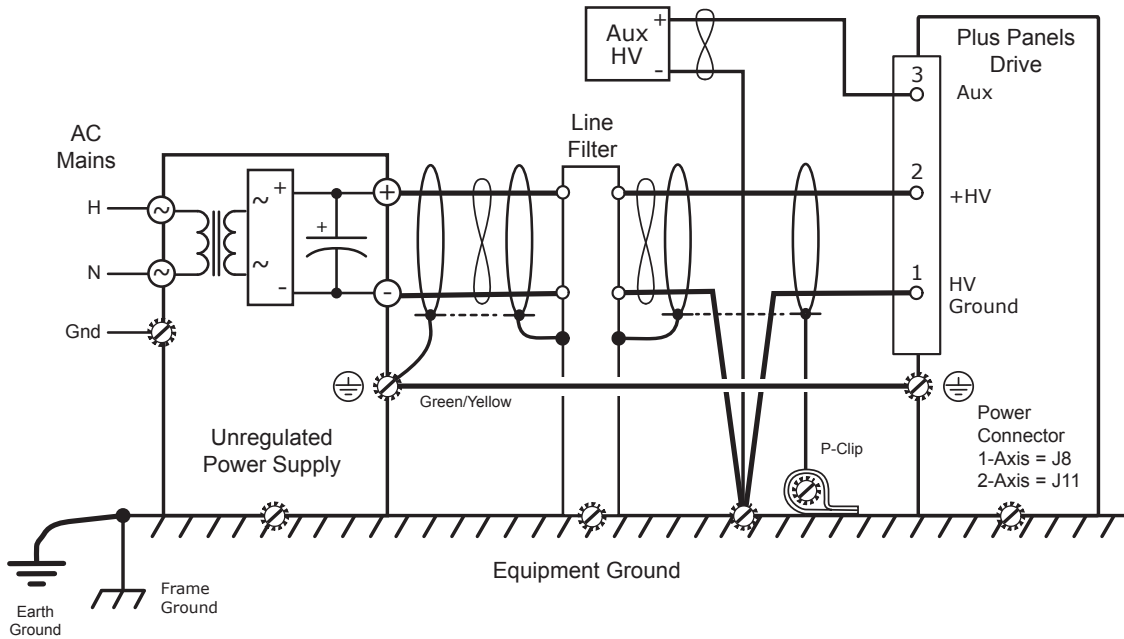

+HV POWER SUPPLY REQUIREMENTS

Regulated Power Supplies

- Must be over-voltage protected to 100 Vdc max when the STO (Safe Torque Off) feature of the drive is used.
- Require a diode and external capacitor to absorb regenerative energy.
- The VA rating should be greater than the actual continuous output power of the drives connected to the power supply, and adequate for the transient output power due to acceleration of motor loads.
- Must handle the internal capacitance of the drives on startup.

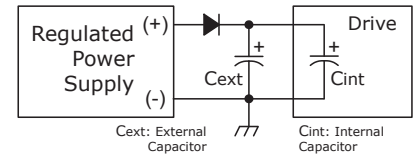

Unregulated Power Supplies

- No-load, high-line output voltage must not exceed 90 Vdc.
- Power supply internal capacitance adds to the drive's internal capacitance for absorption of regenerative energy.
- The VA (Volts & Amps) rating at the power supply's AC input is typically 30~40% greater than the total output power of the drives.

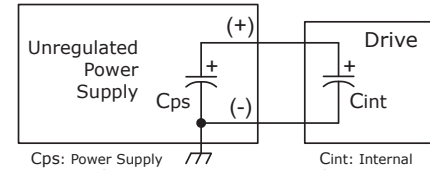

AUXILIARY HV POWER

- Aux HV is power that can keep the drive communications and feedback circuits active when the PWM output stage has been disabled by removing the main +HV supply.
- Useful during EMO (Emergency Off) conditions where the +HV supply must be removed from the drive and powered-down to ensure operator safety.
- Voltage range is the same as +HV.
- Powers the DC/DC converter that supplies operating voltages to the drive DSP and control circuits.
- Aux HV draws no current when the +HV voltage is greater than the Aux HV voltage.

MOTOR CONNECTIONS

- Motor cable shield connects to motor frame, is grounded with a P-clip near the drive and terminates in a ring-lug that is screwed to the drive chassis by a mounting screw to the panel
- If provided, a green/yellow grounding wire from the motor connects to the F.G. terminal of the motor connector.

FEEDBACK CONNECTIONS

- Cable shield connects to motor frame and to the F.G. terminal of the feedback connector.
- When double-shielding is used, the inner shields connect to the Signal Ground at the drive, and is not connected at the motor end.
- If not provided by the motor manufacturer, feedback cables rated for RS-422 communications are recommended for digital encoders.

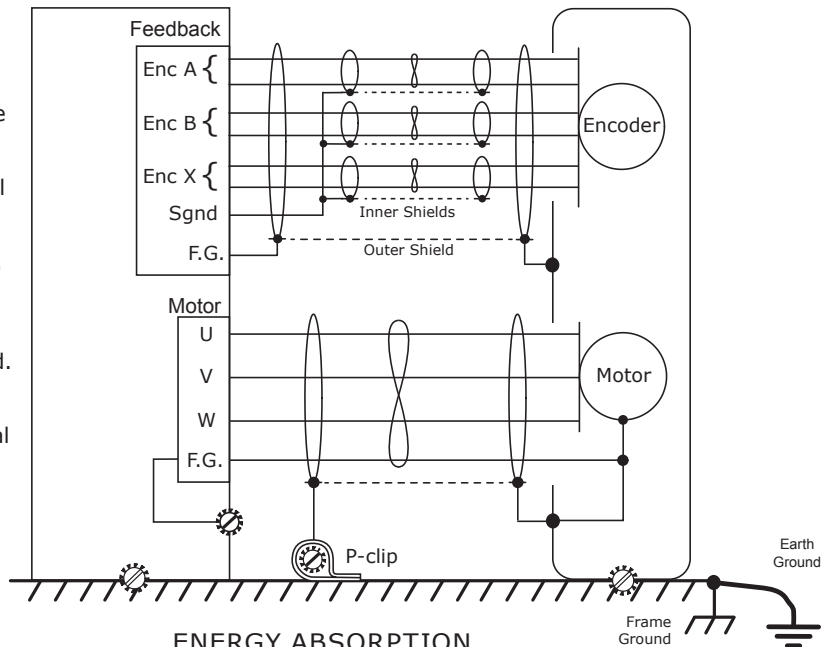

REGENERATION

This chart shows the energy absorption in W-s for the drive operating at some typical DC voltages. It is based on the internal 1360 uF capacitance and would be increased by the capacitance of the external DC power supply. When the load mechanical energy is greater than these values an external regenerative energy dissipater is required, or the DC power supply capacitance can be increased to absorb the regen energy.

ENERGY ABSORPTION

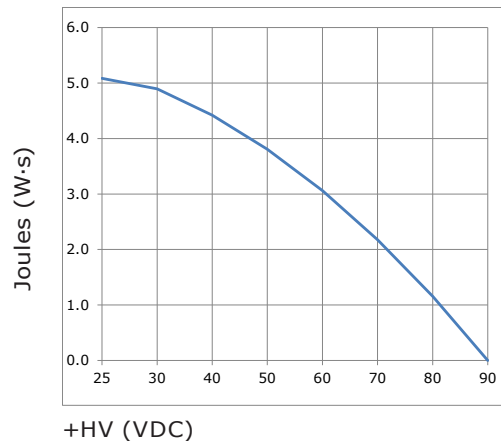

CONNECTORS & SIGNALS: FRONT PANEL

J6 SAFETY (SAFETORQUE OFF)

PIN	SIGNAL	PIN	SIGNAL
1	Frame Gnd	6	STO-1(+)
2	STO-1(+)	7	STO-1(-)
3	STO-1(-)	8	STO-24V
4	STO-2(+)	9	STO-GND
5	STO-2(-)		

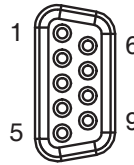

J6 BE2 CONNECTOR:

Dsub DB-09F, 9 position female receptacle

J6 CABLE CONNECTOR:

Dsub DB-09M, 9 position

Details on the cable connectors shown here can be found in the BE2-CK listing under the Accessories section of the last page

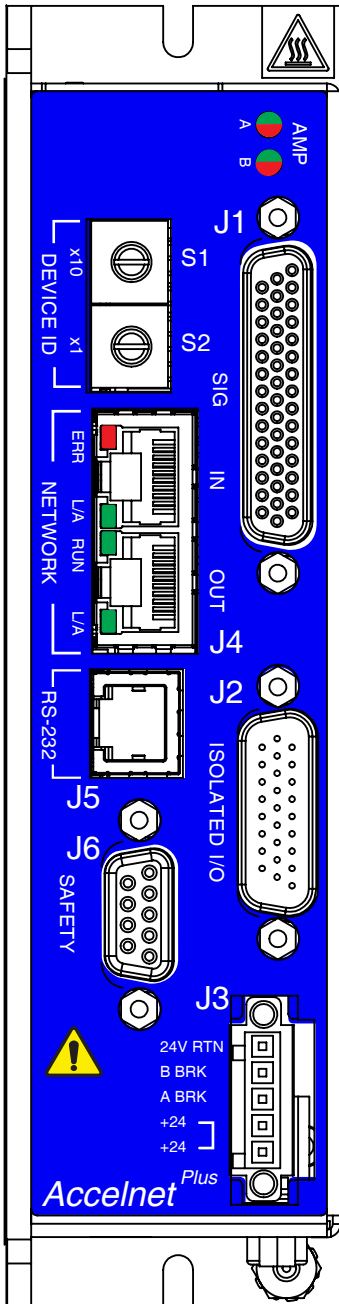

J1: CONTROL SIGNAL

PIN	SIGNAL	PIN	SIGNAL	PIN	SIGNAL
44	Signal Gnd	30	N/C	15	[IN13] Diff2(-)
43	N/C	29	N/C	14	[IN12] Diff2(+)
42	B-MultiEnc A	28	N/C	13	[IN11]
41	B-MultiEnc B	27	B-MultiEnc /A	12	[IN10]
40	B-MultiEnc X	26	B-MultiEnc /B	11	N/C
39	B-MultiEnc S	25	B-MultiEnc /X	10	[IN4] Diff1(-)
38	B +5Vdc Out2	24	B-MultiEnc /S	9	[IN3] Diff1(+)
37	Signal Gnd	23	B +5Vdc Out2	8	[IN2]
36	A-MultiEnc A	22	Signal Gnd	7	[IN1]
35	A-MultiEnc B	21	A-MultiEnc /A	6	Signal Gnd
34	A-MultiEnc X	20	A-MultiEnc /B	5	[AIN2+]
33	A-MultiEnc S	19	A-MultiEnc /X	4	[AIN2-]
32	A +5Vdc Out1	18	A-MultiEnc /S	3	[AIN1+]
31	Signal Gnd	17	A +5Vdc Out1	2	[AIN1-]
		16	Signal Gnd	1	Frame Gnd

J1: DRIVE CONNECTOR

High-Density Dsub DB-44F, female receptacle, 44 Position

J2: CABLE CONNECTOR

High-Density Dsub DB-44M, male plug, 44 Position

J2: ISOLATED I/O

PIN	SIGNAL	1PIN	SIGNAL	PIN	SIGNAL
19	[OUT1+] GPI	10	[OUT1-] GPI	1	Frame Ground
20	[OUT2+] GPI	11	[OUT2-] GPI	2	[IN5] GPI
21	[OUT3+] GPI	12	[OUT3-] GPI	3	[IN6] GPI
22	[OUT4+] GPI	13	[OUT4-] GPI	4	[IN7] GPI
23	[OUT5+] GPI	14	[OUT5-] GPI	5	[IN8] GPI
24	N/C	15	N/C	6	COM1 [IN5~8]
25	N/C	16	N/C	7	[IN14] GPI
26	N/C	17	COM2 [IN14~17]	8	[IN15] GPI
		18	[IN17] GPI	9	[IN16] GPI

J2: DRIVE CONNECTOR

High-Density Dsub DB-26M, male plug, 26 Position

J2: CABLE CONNECTOR

High-Density Dsub DB-26F, female receptacle, 26 Position

J3: BRAKE

CONNECTORS & SIGNALS: FRONT PANEL

J3: BRAKE

Pin	Signal
1	24V Return
2	Brake B [OUT7]
3	Brake A [OUT6]
4	Brk 24V Output
5	Brk 24V Input

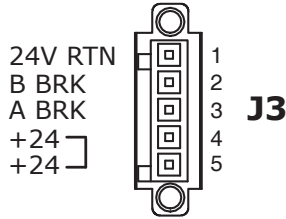

J3: DRIVE CONNECTOR

Euro-style 3.5 mm male receptacle, 5-position
Wago: MCS-MINI, 734-165/108-000

J3: CABLE CONNECTOR

Wago MCS-MINI 734-105/107-000
or 734-105/107-000

WAGO CONNECTOR TOOL

Contact opener: 734-231 operating tool

CONNECTORS & SIGNALS: END PANEL

J7, J8: AXIS A, B FEEDBACK

PIN	SIGNAL	PIN	SIGNAL	PIN	SIGNAL
1	Frame Gnd	10	A(B) Enc /B	19	A(B) Sin(+)
2	A(B) Hall U	11	A(B) Enc B	20	A(B) Cos(-)
3	A(B) Hall V	12	A(B) Enc /A	21	A(B) Cos(+)
4	A(B) Hall W	13	A(B) Enc A	22	N/C
5	Signal Gnd	14	A(B) Enc /S	23	N/C
6	A(B) +5VOut1(2)	15	A(B) Enc S	24	N/C
7	[IN9(18)] A(B) Motemp	16	Signal Gnd	25	Signal Gnd
8	A(B) Enc /X	17	A(B) +5VOut1(2)	26	Signal Gnd
9	A(B) Enc X	18	A(B) Sin(-)		

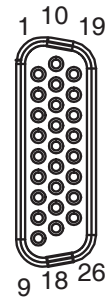

J7, J8

J7, J8: FEEDBACK

J7, J8: BE2 CONNECTOR
High-Density Dsub DB-26F,
female receptacle, 26 Position

J7, J8: CABLE CONNECTOR
High-Density Dsub DB-26M,
male plug, 26 Position

J9, J10

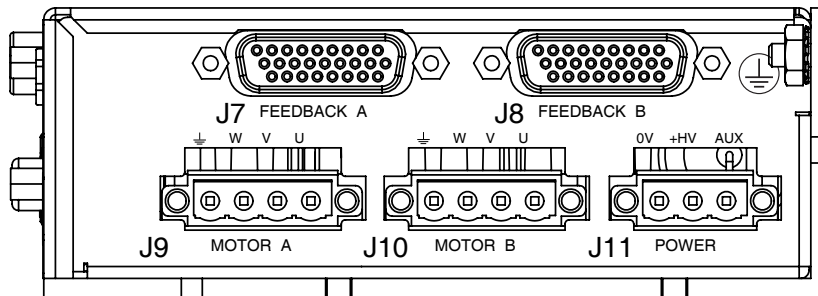
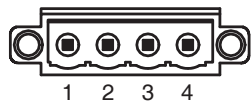

J11

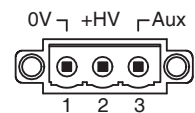

J9, J10: MOTOR OUTPUTS

Signal	Pin
Frame Ground	1
Motor Phase W	2
Motor Phase V	3
Motor Phase U	4

J9, J10: DRIVE CONNECTORS

Euro-style 5.08 mm male receptacle, 4-position
Wago: MCS-MIDI, 231-564/108-000

J9, J10 CABLE CONNECTORS

Wago MCS-MIDI Classic 231-304/107-000

WAGO CONNECTOR TOOL

Contact opener: 231-159 operating tool

J11: +HV & AUX POWER

Signal	Pin
HV Ground	1
HV	2
Aux HV	3

J11: DRIVE CONNECTOR

Euro-style 5.08 mm male receptacle, 3-position
Wago: MCS-MIDI, 231-563/108-000

J11: CABLE CONNECTOR

Wago MCS-MIDI, 231-303/107-000

WAGO CONNECTOR TOOL

Contact opener: 231-159 operating tool

CONNECTORS & SIGNALS: END PANEL (-R MODELS WITH RESOLVER FEEDBACK)

J7, J8: AXIS A, B FEEDBACK

PIN	SIGNAL	PIN	SIGNAL	PIN	SIGNAL
1	Frame Gnd	10	N.C.	19	A(B) Sin(+) S3
2	A(B) Hall U	11	N.C.	20	A(B) Cos(-) S4
3	A(B) Hall V	12	N.C.	21	A(B) Cos(+) S2
4	A(B) Hall W	13	N.C.	22	A(B) Ref(-) R2
5	Signal Gnd	14	N.C.	23	A(B) Ref(+) R1
6	A(B) +5VOut1(2)	15	N.C.	24	N/C
7	[IN9(18)] A(B) Motemp	16	Signal Gnd	25	Signal Gnd
8	N.C.	17	A(B) +5VOut1(2)	26	Signal Gnd
9	N.C.	18	A(B) Sin(-) S1		

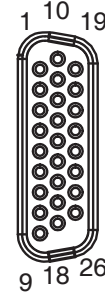

J7, J8

J7, J8: FEEDBACK

J7, J8: BE2 CONNECTOR
High-Density Dsub DB-26F,
female receptacle, 26 Position

J7, J8: CABLE CONNECTOR
High-Density Dsub DB-26M,
male plug, 26 Position

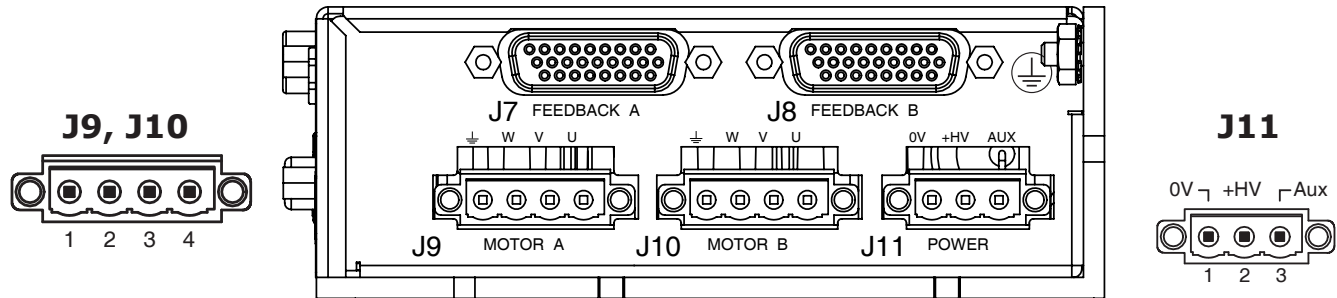

J9, J10

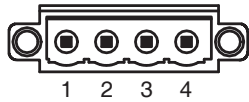

J9, J10: MOTOR OUTPUTS

Signal	Pin
Frame Ground	1
Motor Phase W	2
Motor Phase V	3
Motor Phase U	4

J9, J10: DRIVE CONNECTORS

Euro-style 5.08 mm male receptacle, 4-position
Wago: MCS-MIDI, 231-564/108-000

J9, J10 CABLE CONNECTORS

Wago MCS-MIDI Classic 231-304/107-000

WAGO CONNECTOR TOOL

Contact opener: 231-159 operating tool

J11: +HV & AUX POWER

Signal	Pin
HV Ground	1
HV	2
Aux HV	3

J11: DRIVE CONNECTOR

Euro-style 5.08 mm male receptacle, 3-position
Wago: MCS-MIDI, 231-563/108-000

J11: CABLE CONNECTOR

Wago MCS-MIDI, 231-303/107-000

WAGO CONNECTOR TOOL

Contact opener: 231-159 operating tool

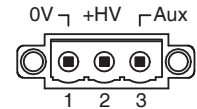

WIRING

24V & BRAKE: J3

Wago MCS-MINI: 735-105/107-000, female connector; with screw flange, 5-pole; pin spacing 3.5 mm / 0.138 in

Conductor capacity

Bare stranded:

Insulated ferrule:

Stripping length:

Operating tool:

AWG 28~16 [0.08~1.5 mm²]

AWG 24~16 [0.25~1.5 mm²]

0.24~0.28 in [6~7 mm]

Wago MCS-MINI: 734-231

J3

Tool



FERRULE PART NUMBERS: SINGLE WIRE INSULATED

AWG	mm ²	Color	Mfgr	PNUM	A	B	C	D	E	SL
18	1.0	Red	Wago	216-223	12.0 (.47)	6.0 (.24)	1.4 (.06)	3.0 (.12)	3.5 (.14)	8 (.31)
20	0.75	Gray	Wago	216-222	12.0 (.47)	6.0 (.24)	1.2 (.05)	2.8 (.11)	3.3 (.13)	8 (.31)
22	0.5	White	Wago	216-221	12.0 (.47)	6.0 (.24)	1.0 (.04)	2.6 (.10)	3.1 (.12)	7.5 (.30)

FERRULE PART NUMBERS: DOUBLE WIRE INSULATED

AWG	mm ²	Color	Mfgr	PNUM	A	B	C	D	E	SL
2 x 18	2 x 1.0	Red	Altech	2776.0	15.4 (.61)	8.2 [.32]	2.4 (.09)	3.2 (.13)	5.8 (.23)	11.0 (.43)
2 x 18	2 x 1.0	Gray	Altech	2775.0	14.6 (.57)	8.2 (.32)	2.0 (.08)	3.0 (.12)	5.5 (.22)	11.0 (.43)
2 x 20	2 x 0.75	White	Altech	2794.0	14.6 (.57)	8.2 (.32)	1.7 (.07)	3.0 (.12)	5.0 (.20)	11.0 (.43)
2 x 20	2 x 0.75	Gray	TE	966144-2	15.0 (.59)	8.0 (.31)	1.70 (.07)	2.8 (.11)	5.0 (.20)	10 (.39)
2 x 22	2 x 0.50	White	TE	966144-1	15.0 (.59)	8.0 (.31)	1.40 (.06)	2.5 (.10)	4.7 (.19)	10 (.39)

SINGLE WIRE

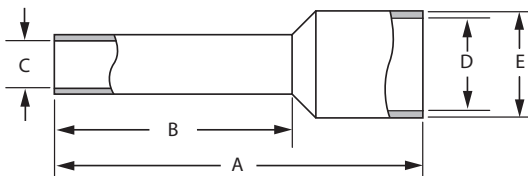

DOUBLE WIRE

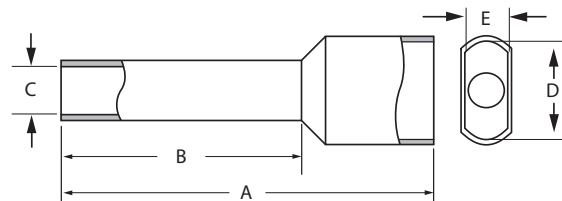

MOTOR OUTPUTS AND HV/AUX POWER: J9, J10, J11

Wago MCS-MIDI Classic: 231-304/107-000 (J9, J10), 231-303/107-000 (J11), female connector; with screw flange; 3-pole; pin spacing 5.08 mm / 0.2 in

Conductor capacity

Bare stranded:

Insulated ferrule:

Stripping length:

Operating Tool:

AWG 28~14 [0.08~2.5 mm²]

AWG 24~16 [0.25~1.5 mm²]

8~9 mm

Wago MCS-MIDI Classic: 231-159

J9, J10

J11

Tool



FERRULE PART NUMBERS: SINGLE WIRE INSULATED

AWG	mm ²	Color	Mfgr	PNUM	A	B	C	D	E	SL
14	2.5	Blue	Wago	216-206	15.0 (0.59)	8.0 (0.31)	2.05 (.08)	4.2 (0.17)	4.8 (0.19)	10 (0.39)
16	1.5	Black	Wago	216-204	14.0 (0.59)	8.0 (0.31)	1.7 (.07)	3.5 (0.14)	4.0 (0.16)	10 (0.39)
18	1.0	Red	Wago	216-223	12.0 (.47)	6.0 (.24)	1.4 (.055)	3.0 (.12)	3.5 (.14)	8 (.31)
20	0.75	Gray	Wago	216-222	12.0 (.47)	6.0 (.24)	1.2 (.047)	2.8 (.11)	3.3 (.13)	8 (.31)
22	0.5	White	Wago	216-221	12.0 (.47)	6.0 (.24)	1.0 (.039)	2.6 (.10)	3.1 (.12)	7.5 (.30)

NOTES

PNUM = Part Number

SL = Stripping length

Dimensions: mm (in)

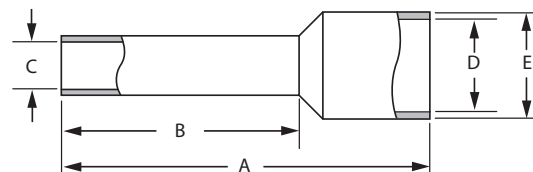

THERMALS: POWER DISSIPATION

The top chart on this page shows the internal power dissipation for one axis of the BE2 under differing power supply and output current conditions. The +HV values are for the average DC voltage of the drive power supply. The lower chart shows the temperature rise vs. power dissipation under differing mounting and cooling conditions.

TOTAL POWER DISSIPATION

Use this chart to find the total power dissipation for both axes.

Example:

Power supply HV = 65 Vdc
 Axis 1 current = 7.5 A, axis 2 = 9.0 A
 Total current = 16.5 A
 Total dissipation = 19 Watts

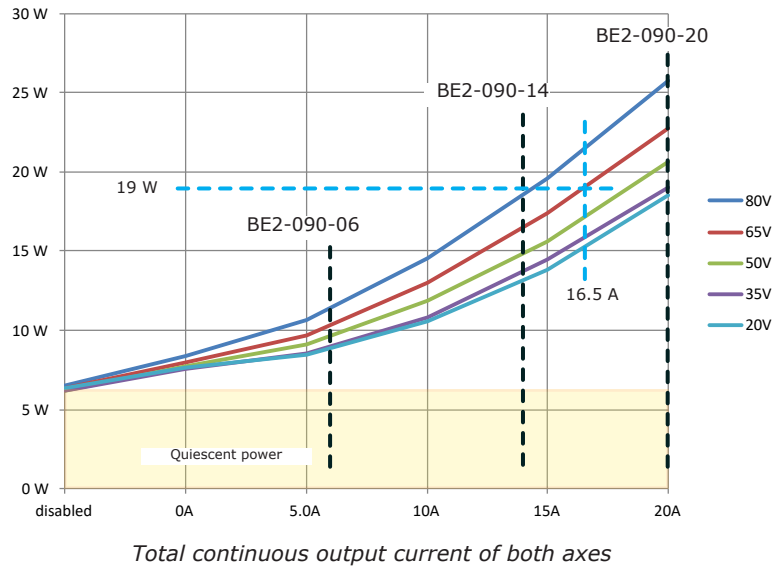

THERMALS: MAXIMUM OPERATING TEMPERATURE VS. DISSIPATION

Use this chart to find the maximum operating temperature of the drive under differing mounting and cooling conditions.

Example:

Using the 19 W value from the calculations above, draw a vertical line. This shows that 24 C is the maximum operating temperature for NHSNF, and that any of the other mounting/cooling options will be sufficient for operation up to the maximum ambient temperature of 45 C.

- HSF = Heat Sink (with) Fan
- NHSF = No Heat Sink (with) Fan
- HSNF = Heat Sink No Fan
- NHSNF = No Heat Sink No Fan

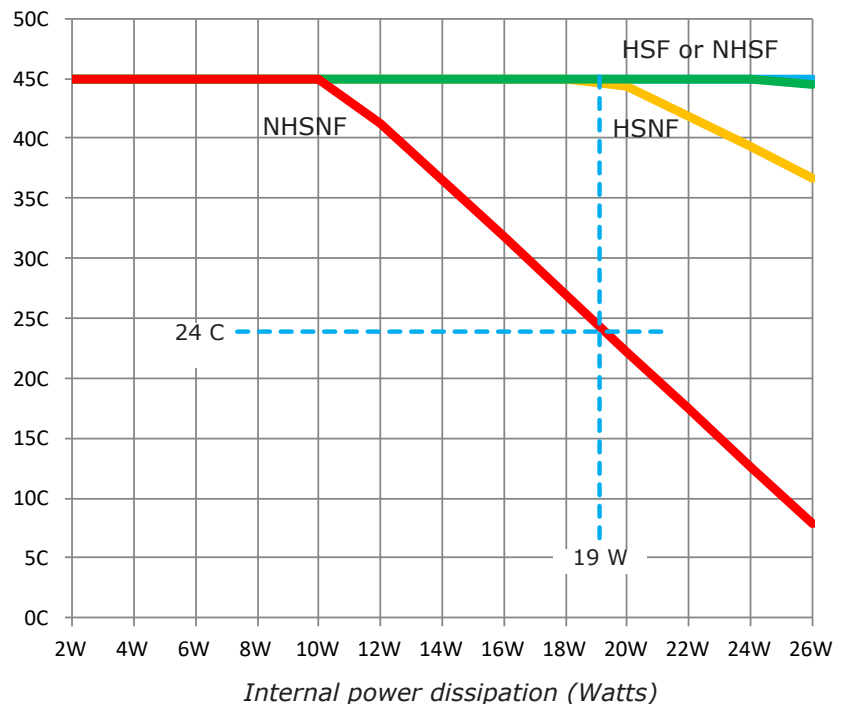

THERMALS: MOUNTING & THERMAL RESISTANCE

MOUNTING

Thermal data for convection-cooling with a heatsink assumes a vertical mounting of the drive on a thermally non-conducting surface. Heatsink fins run parallel to the long axis of the drive. When fan-cooling is used vertical mounting is not necessary to guarantee thermal performance of the heatsink.

THERMAL RESISTANCE

Thermal resistance is a measure of the temperature rise of the drive heatplate due to power dissipation in the drive. It is expressed in units of °C/W where the degrees are the temperature rise above ambient.

E.g., an drive dissipating 16 W mounted with no heatsink or fan would see a temperature rise of 38.2C above ambient based on the thermal resistance of 2.39C/W. Using the drive maximum heatplate temperature of 70C and subtracting 38.2C from that would give 31.7C as the maximum ambient temperature the drive in which the drive could operate before going into thermal shutdown. To operate at higher ambient temperatures a heatsink or forced-air would be required.

TOP VIEWS VERTICAL MOUNTING

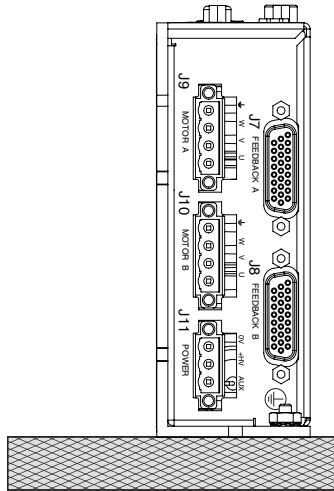

NO HEATSINK, NO FAN	°C/W
CONVECTION	2.32

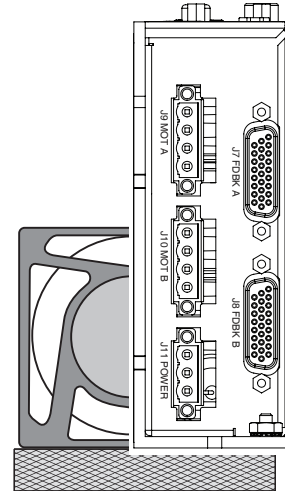

NO HEATSINK + FAN	°C/W
FORCED-AIR, 300 LFM	0.98

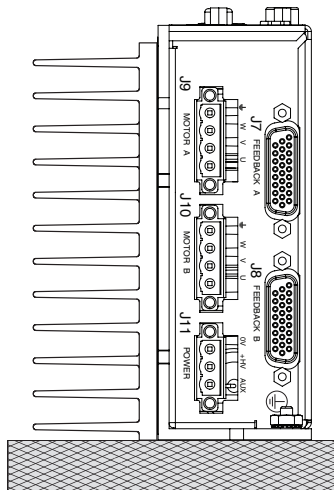

HEATSINK, NO FAN	°C/W
CONVECTION	1.28

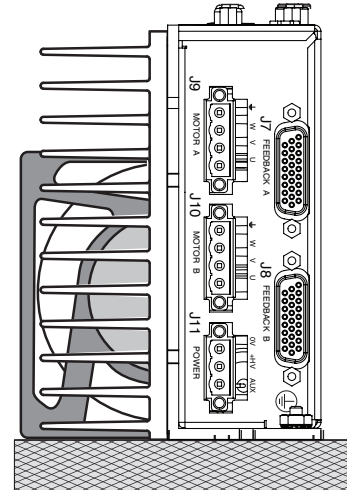

HEATSINK + FAN	°C/W
FORCED-AIR, 300 LFM	0.61

HEATSINK KIT INSTALLATION

- Standard heatsink for Accelnet Plus Panel BE2
- Complete kit for user installation of the heatsink

DESCRIPTION

The BE2-HK is a kit containing a heatsink and mounting hardware for field installation of a standard heatsink onto a BE2 model servo drive.

BE2-HK HEATSINK KIT PART LIST

Qty	Description	
1	Heatsink, standard, BE2-HS	
1	Thermal material, 4x4 in.	
1	Kit, Heatsink Hardware, BE2	
	4	Washer, flat, #8
	4	Screw, PAN, SEMS, #8-32 x 1/2 in

INSTALLATION

- 1) Place the heatsink fins-down on a work surface. Orient the heatsink so that the edge with part number is away from you. The hole for the BE2 grounding lug should be to your left.
- 2) Remove the clear protective film from the thermal material and discard it. Place the thermal material onto the heatsink in the placement area which is marked with four white "L". Apply light pressure to ensure that the thermal material is flat.
- 3) Peel the white protective layer away from the thermal material. Do this slowly from one corner so as not to lift the thermal material from the heatsink.
- 4) Align the BE2 as shown and lower onto the heatsink. If needed to adjust the position, lift it away from the thermal material and lower onto the heatsink again.
- 5) Install the four mounting screws with flat washers and tighten evenly. Torque to 17.8 lb-in (2.0 Nm) maximum.

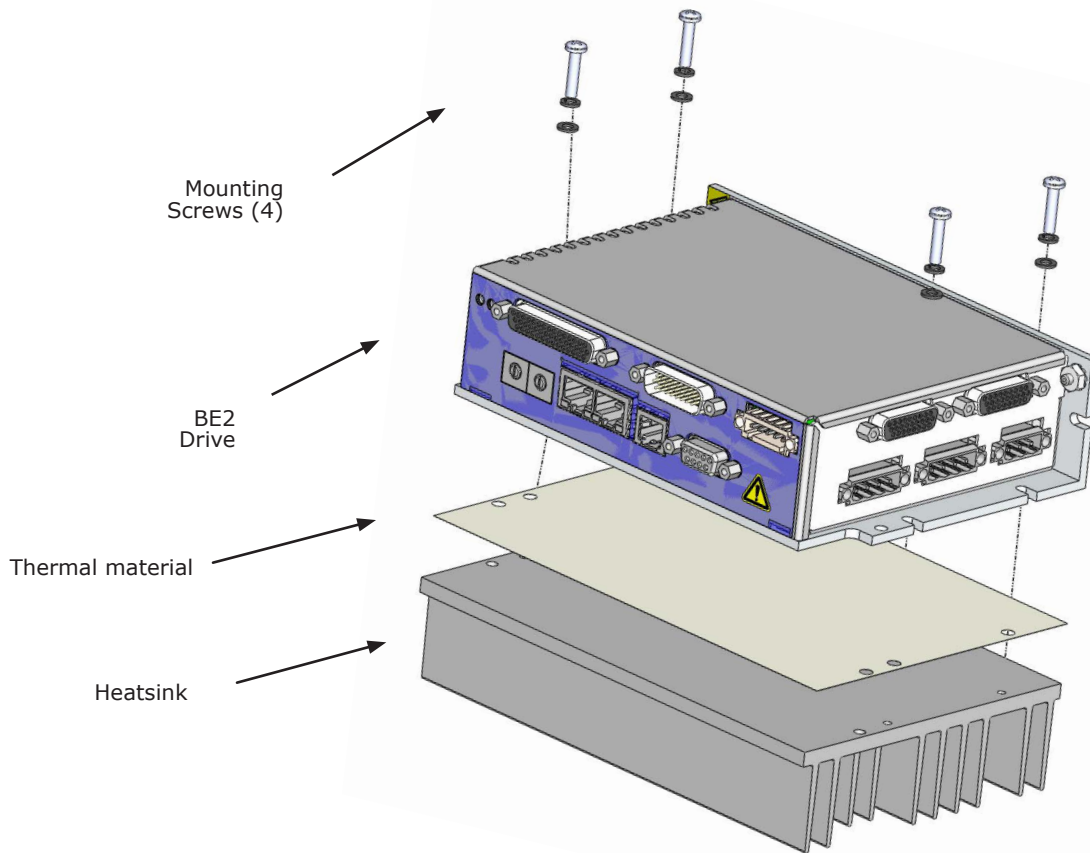

DIMENSIONS: IN (MM)

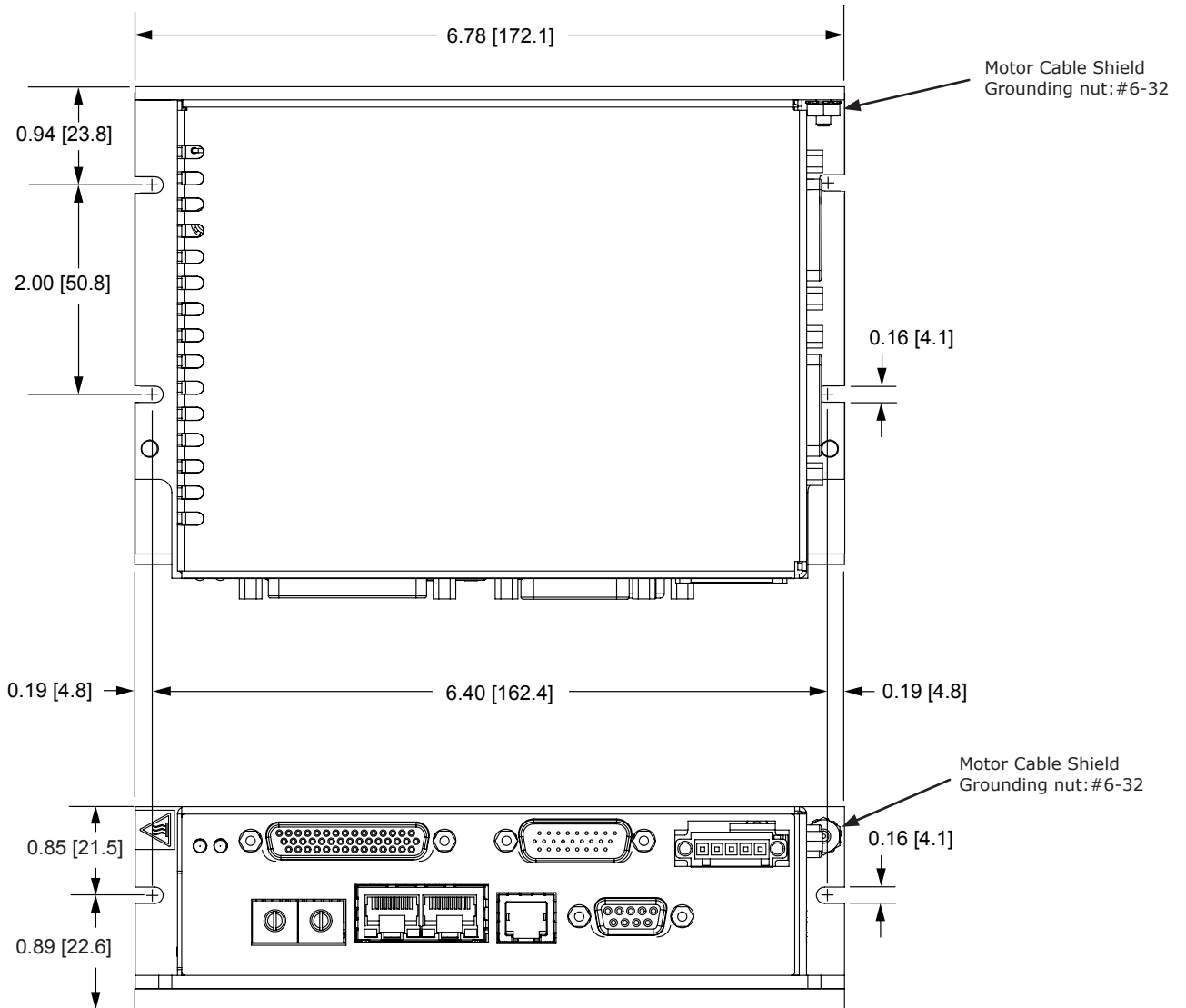

Mounting screws:
#6-32, or 3.5 mm

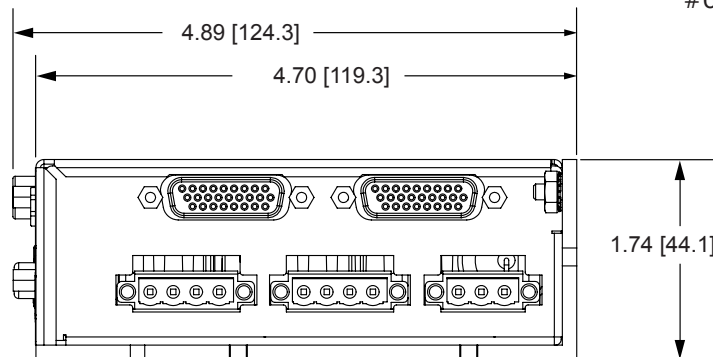

DIMENSIONS: IN (MM)

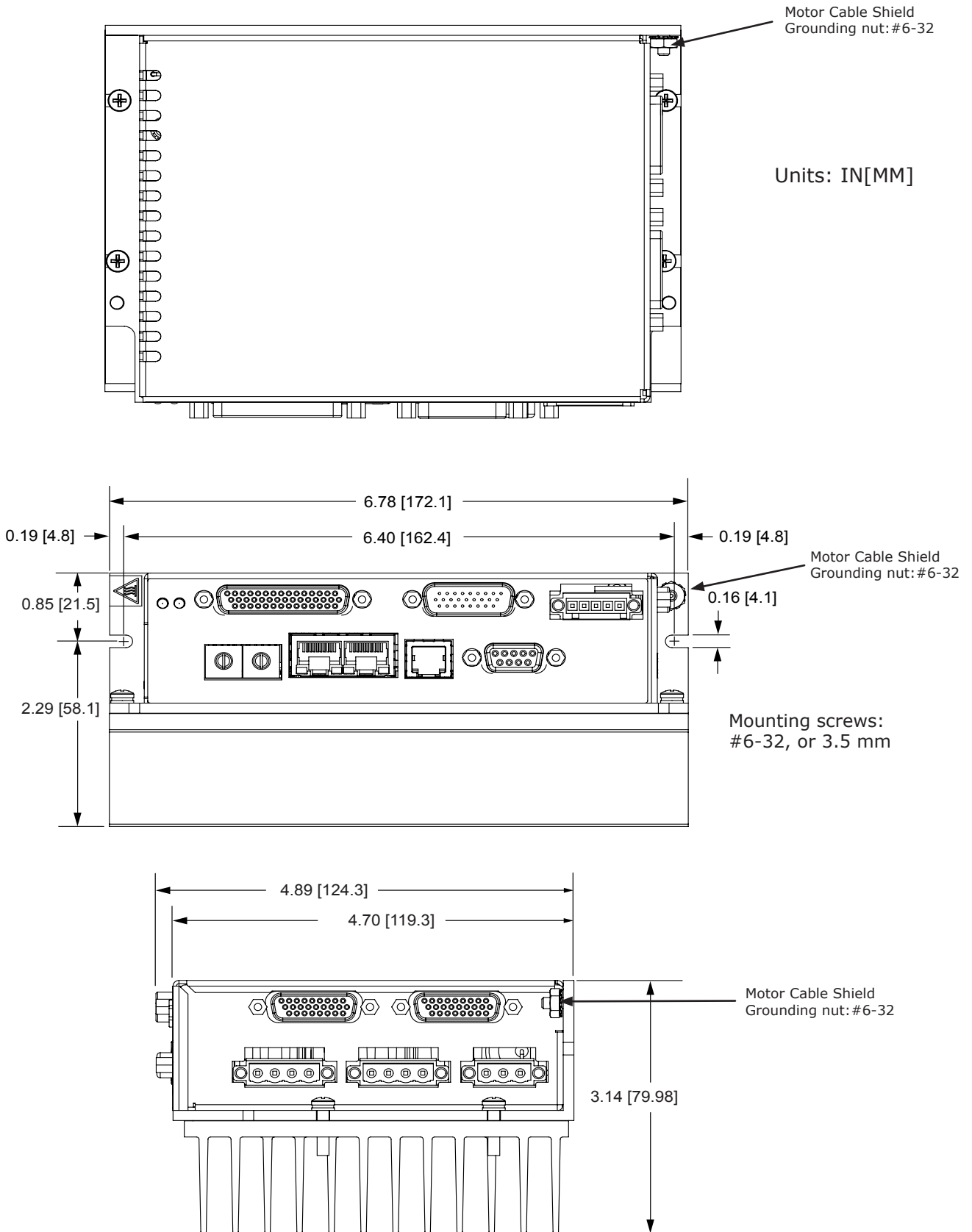

INSTALLATION

The graphic below shows the recommended mounting for multiple drives. The clearances shown are minimums.

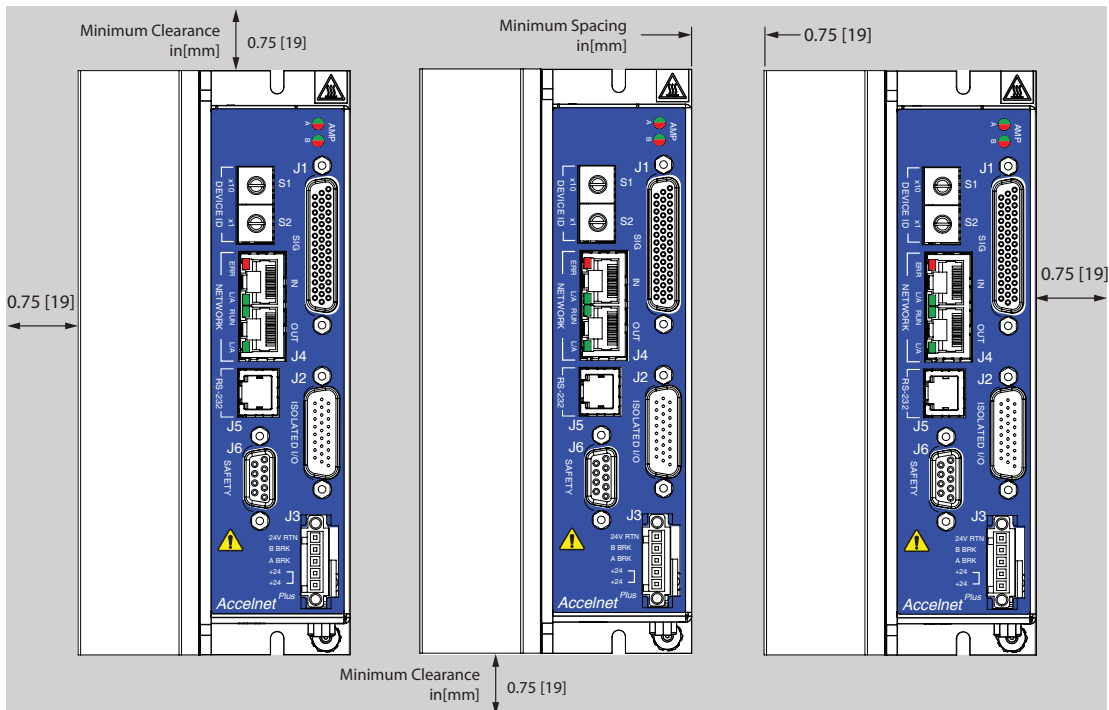
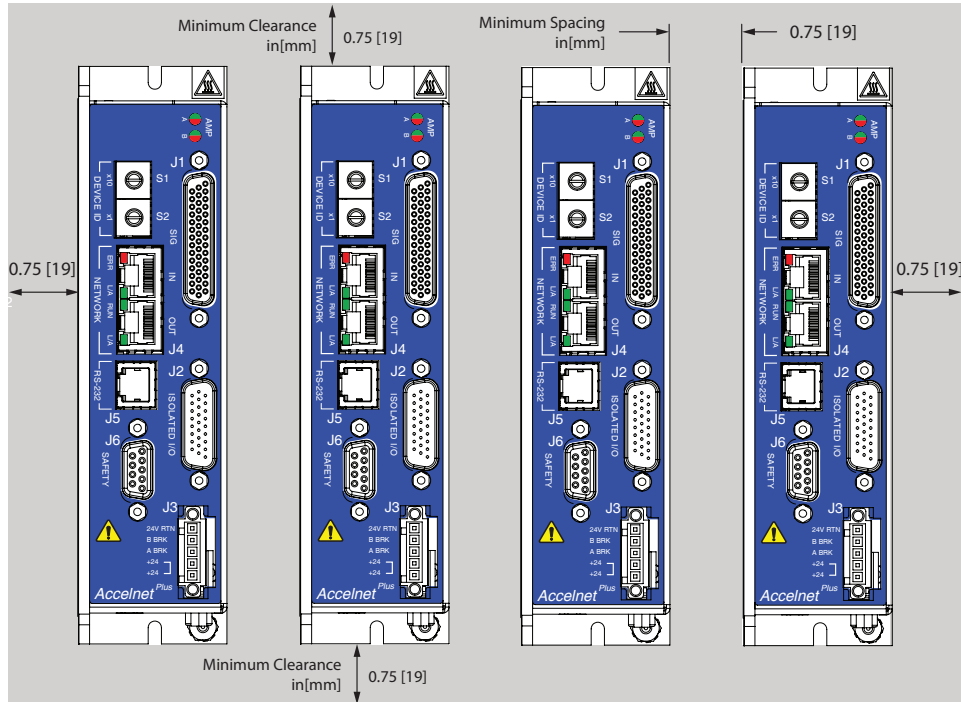

ORDERING GUIDE

BE2-090-06	Accelnet Plus 2-Axis Panel EtherCAT servo drive, 3/6 A, 90 Vdc
BE2-090-14	Accelnet Plus 2-Axis Panel EtherCAT servo drive, 7/14 A, 90 Vdc
BE2-090-20	Accelnet Plus 2-Axis Panel EtherCAT servo drive, 10/20 A, 90 Vdc



Add -R to model number for resolver feedback option (Example: BE2-090-14-R)

Example: Order one Accelnet Plus BE2 drive, 7/14 A, resolver option, with connector kit, serial cable kit:

Qty	Item	Remarks
1	BE2-090-14-R	Accelnet Plus BE2 2-axis servo drive, resolver option
1	BE2-CK	BE2 Connector Kit
1	SER-CK	Serial Cable Kit

ACCESSORIES

	Qty	Ref	Name	Description	Manufacturer P/N
BE2-CK Connector Kit	1	J11	DC HV	Plug, 3 position, 5.08 mm, female	Wago: 231-303/107-000 (Note 1)
	1			Strain relief, snap-on, 5.08 mm, 3 position, orange	Wago: 232-633
	2	J9, J10	Motor	Plug, 4 position, 5.08 mm, female	Wago: 231-304/107-000 (Note 1)
	2			Strain relief, snap-on, 5.08 mm, 4 position, orange	Wago: 232-634
	1	J9~J11	Tool	Tool, wire insertion & extraction, 231 series	Wago: 231-159
	1	J3	Brake	Plug, 5 position, 3.5 mm, female	Wago: 734-105/107-000 (Note 1)
	1			Strain relief, snap-on, 3.5 mm, 5 position, grey	Wago: 734-605
	1		Tool	Tool, wire insertion & extraction, 734 series	Wago: 734-231
	1	J6 Note 2	Safety	Connector, DB-9M, 9-position, standard, male	TE/AMP: 205204-4
	9			AMPLIMITE HD-20 Crimp-Snap contacts, 24-20AWG, AU flash	TE/AMP: 66506-9
	1			Metal Backshell, DB-9, RoHS	3M: 3357-9209
	4			Jumper, with pins crimped on both ends	Copley: 10-75177-01
	1	J1	Control	Connector, high-density DB-44M, 44 position, male, solder cup	Norcomp: 180-044-103L001
	1			Metal Backshell, DB-25, RoHS	3M: 3357-9225
	1	J2	I/O	Connector, high-density DB-26F, 26 position, female, solder cup	Norcomp: 180-026-203L001
	2	J7, J8	Feed-back	Connector, high-density DB-26M, 26 position, male, solder cup	Norcomp: 180-026-103L001
	3	J2, J7, J8		Metal Backshell, DB-15, RoHS	3M: 3357-9215
	SER-CK	1	J5	RS-232	Serial Cable Kit
BE2-NC-10	1	J8	Network	EtherCAT® network cable, 10 ft (3 m)	
BE2-NC-01	1			EtherCAT® network cable, 1 ft (0.3 m)	

Note 1: For RoHS compliance, append "/RN01-0000" to the Wago part numbers listed above

Note 2: Insertion/extraction tool for J6 contacts is AMP/Tyco 91067-2 (not included in BE2-CK)

16-01440 Document Revision History

Revision	Date	Remarks
00	March 27, 2017	Initial released version
01	July 3, 2018	Corrections to J-numbering, updated agency standards
02	June 30, 2020	Corrections to resolver signals on p. 16, updated agency standards
03	November 5, 2020	Correction to pin numbering on brake connector J3
04	August 17, 2021	Page 40 changed KFE-632-8ET to KFE-440-4ET Update with new front panel label to show brake signals

EtherCAT is a registered trademark and patented technology, licensed by Beckhoff Automation GmbH, Germany.

Note: Specifications subject to change without notice