FEATURES

- **CE Compliance to 89/336/EEC**
- **Recognized Component to UL 508C**
- **Complete torque (current) mode functional block**
- **Single supply voltage: 18-55VDC**
- **5A continuous, 10A peak more than double the power output of servo chip sets**
- **Fault protections:**
Short-circuits from output to output, output to ground
Over/under voltage
Over temperature
Self-reset or latch-off
- **2.5kHz bandwidth**
- **Wide load inductance range 0.2-40 mH.**
- **Separate continuous, peak and peak-time current limits**
- **Surface mount technology**

APPLICATIONS

- **X-Y stages**
- **Robotics**
- **Automated assembly machinery**
- **Component insertion machines**

THE OEM ADVANTAGE

- **NO POTS: Internal component header configures amplifier for custom applications**
- **Conservative design for high MTBF**
- **Low cost solution for small brush motors to 1/3 HP**

±50 Volts output at ±10A Peak, ±5A Continuous



PRODUCT DESCRIPTION

Model 403 is a complete PWM servoamplifier for applications using DC brush motors in torque (current) mode. It provides a full complement of features for motor control. These include remote inhibit/enable, directional enable inputs for connection to limit switches, and protection for both motor and amplifier.

/Enable input has selectable active level (+5V or gnd) to interface with most control cards. /Pos and /Neg enable inputs use fail-safe (ground to enable) logic.

Power delivery is four-quadrant for bi-directional acceleration and deceleration of motors. Model 403 features 500W peak power output in a compact package using SMT technology.

An internal header socket holds components which configure the various gain and current limit settings to customize the 403 for different loads and applications.

Separate peak and continuous current limits allow high acceleration without sacrificing protection against continuous overloads.

Peak current time limit is settable to match amplifier to motor thermal limits.

Header components permit compensation over a wide range of load inductances to maximize bandwidth with different motors.

Package design places all connectors along one edge for easy connection and adjustment while minimizing footprint inside enclosures. High quality components and conservative ratings insure long service life and high reliability in industrial installations.

A differential amplifier buffers the reference voltage input to reject common-mode noise resulting from potential differences between controller and amplifier grounds.

Output short circuits and heatplate overtemperature cause the amplifier to latch into shutdown. Grounding the reset input will enable an auto-reset from such conditions when this feature is desired.

Model 403 DC Brush Servo Amplifier

FUNCTIONAL DIAGRAM

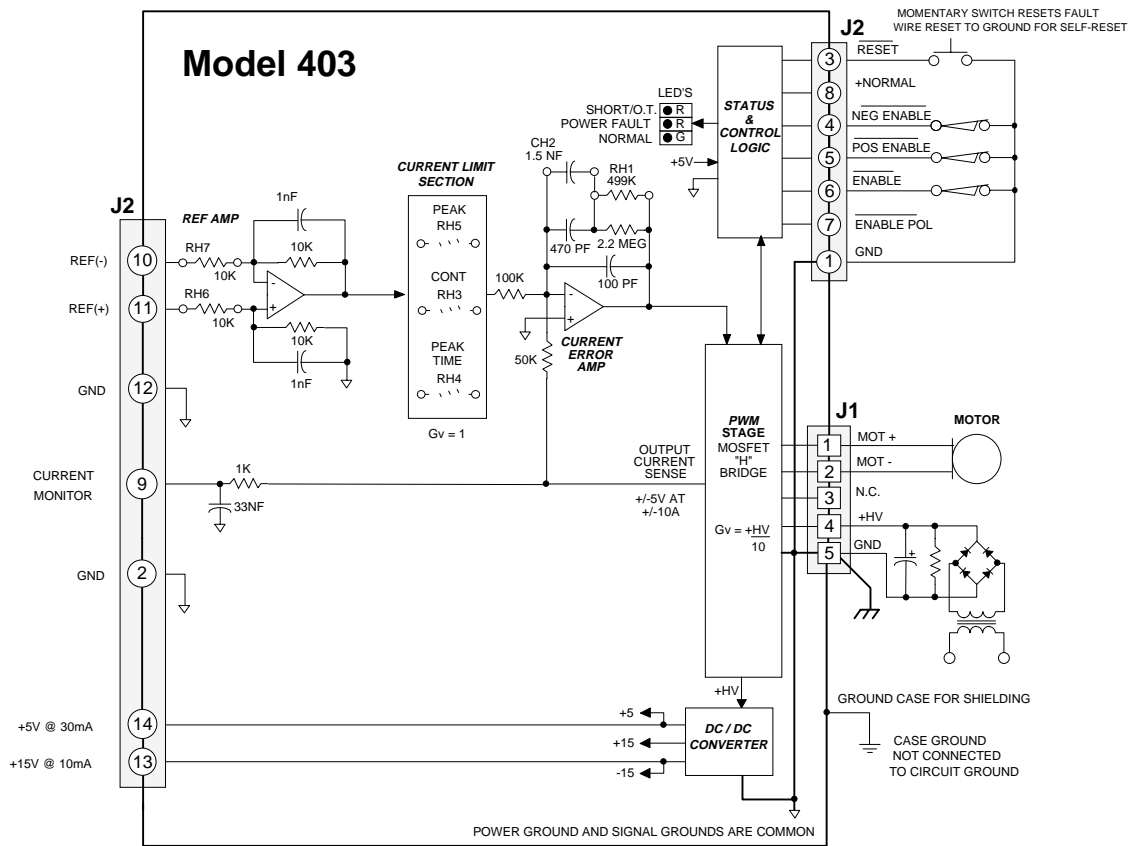

TYPICAL CONNECTIONS

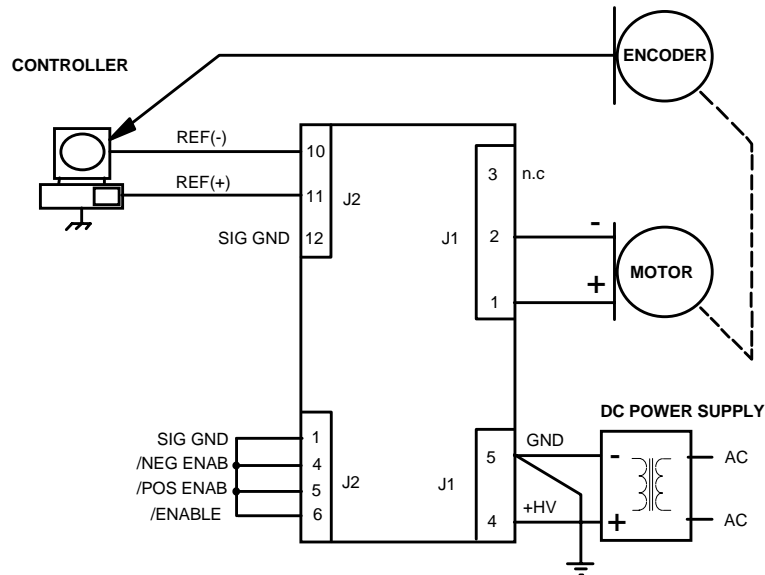

APPLICATION INFORMATION (CONT'D)

COMPONENT HEADER

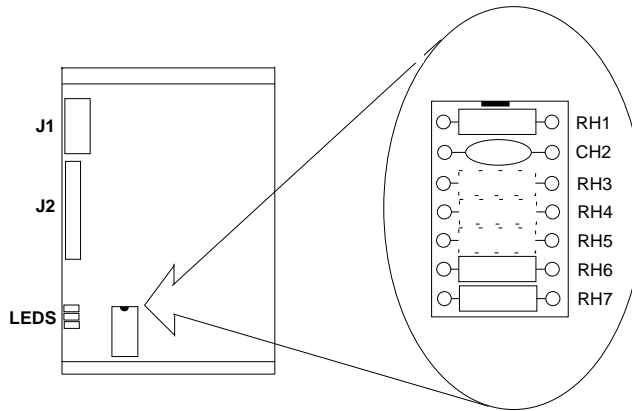

WARNING!
DISCONNECT POWER WHEN CHANGING HEADER COMPONENTS. REPLACE COVER BEFORE APPLYING POWER TO PREVENT CONTACT WITH LIVE PARTS.

- RH1] LOAD INDUCTANCE SETTING
- CH2]
- RH3] CONTINUOUS CURRENT LIMIT
- RH4] PEAK CURRENT TIME LIMIT
- RH5] PEAK CURRENT LIMIT
- RH6] REFERENCE GAIN SETTING
- RH7]

NOTE: Components in dotted lines are not installed at factory

LOAD INDUCTANCE SETTING (RH1 & CH2) Note 1

Load (mH)	RH1	CH2
0.2	49.9 k	1.5 nF
1	150 k	1.5 nF
3	499 k	1.5 nF *
10	499 k	3.3 nF
33	499 k	6.8 nF
40	499 k	10 nF

Notes:

* **Standard values installed at factory are shown in italics.**

1. Bandwidth and values of RH1, CH2 are affected by supply voltage and load inductance. Final selection should be based on customer tests using actual motor at nominal supply voltage.
2. Peak current setting should always be greater than continuous current setting.
3. Peak times will double when current changes polarity. Peak times decrease as continuous current increases.

PEAK CURRENT LIMIT (RH5) Note 2

I _{peak} (A)	RH5 (Ω)
10	open *
8	12k
6	4.7k
4	2k
2	750

CONTINUOUS CURRENT LIMIT (RH3):

I _{cont} (A)	RH3 (Ω)
5	open *
4	20k
3	8.2k
2	3.9k
1	1.5k

PEAK CURRENT TIME-LIMIT (RH4) Note 3

T _{peak} (s)	RH4 (M)
0.5	open *
0.4	10 M
0.2	3.3 M
0.1	1 M

Times shown are for 10A step from 0A

Model 403

DC Brush Servo Amplifier

TECHNICAL SPECIFICATIONS

Typical specifications @ 25°C ambient, +HV = +55VDC. Load = 200µH. in series with 1 ohm unless otherwise specified.

OUTPUT POWER

Peak power	
Unidirectional	±10A @ 50V for 0.5 second, 500W
After direction change	±10A @ 50V for 1 second, 500W
Continuous power	±5A @ 50V, 250W

OUTPUT VOLTAGE

$$V_{out} = (0.97)(HV) - (0.4)(I_{out})$$

MAXIMUM CONTINUOUS OUTPUT CURRENT

Convection cooled, no conductive cooling	±2A @ 35°C ambient
Mounted on narrow edge, on steel plate, fan-cooled 400 ft/min	±5A @ 55°C

LOAD INDUCTANCE

Selectable with components on header socket	200 µH to 40mH (Nominal, for higher inductances consult factory)
---	--

BANDWIDTH

Small signal	-3dB @ 2.5kHz with 200µH load
Note: actual bandwidth will depend on supply voltage, load inductance, and header component selection	

PWM SWITCHING FREQUENCY

25kHz

ANALOG INPUT CHARACTERISTICS

Reference	Differential, 20K between inputs with standard header values
-----------	--

GAINS

Input differential amplifier	X1 as delivered. Adjustable via header components RH6, RH7
PWM transconductance stage	1 A/V (output vs. input to current limit stage)

OFFSET

Output offset current (0 V at inputs)	20 mA max. (0.2% of full-scale)
Input offset voltage	20 mV max (for 0 output current and RH6,7 = 10KΩ)

LOGIC INPUTS

Logic threshold voltage	HI: ≥ 2.5V , LO: ≤ 1.0V, +5V Max on all logic inputs
/Enable	LO enables amplifier (/Enable Pol open) , HI inhibits; 50 ms turn-on delay
/POS enable, /NEG enable	LO enables positive/negative output currents, HI inhibits
/Reset	LO resets latching fault condition, ground for self-reset every 50 ms.
/Enable Pol (Enable Polarity)	LO reverses logic of /Enable input only (HI enables unit, LO inhibits) /POS and /NEG enable not affected by /Enable Pol selection

LOGIC OUTPUTS

+Normal	HI when unit operating normally, LO if overtemp, output short, disabled, or power supply (+HV) out of tolerance HI output voltage = 2.4V min at -3.2 mA max., LO output voltage = 0.5V max at 2 mA max. Note: Do not connect +Normal output to devices that operate >+5V
---------	--

INDICATORS (LED's)

Normal (green)	ON = Amplifier enabled, no shorts or overtemp, power within limits
Power fault (red)	ON = Power fault: +HV < 18V OR +HV > 55V
Short/Overtemp (red)	ON = Output short-circuit or over-temperature condition

CURRENT MONITOR OUTPUT

±5V @ ±10A (2A/volt), 10kΩ, 3.3nF R-C filter

DC POWER OUTPUTS (Total power from +5V and +15V outputs not to exceed 200mW)

+5VDC	30mA max.
+15VDC	10mA max

PROTECTION

Output short circuit (output to output, output to ground)	Latches unit OFF (self-reset if /RESET input grounded)
Overtemperature	Shutdown at 70°C on heatplate (Latches unit OFF)
Power supply voltage too low (Undervoltage)	Shutdown at +HV < 18VDC (operation resumes when power >18VDC)
Power supply voltage too high (Overvoltage)	Shutdown at +HV > 55VDC (operation resumes when power <55VDC)

POWER REQUIREMENTS

DC power (+HV)	18-55 VDC @ 10A peak.
Minimum power consumption	2.5 W
Power dissipation at 5A output, 55VDC supply	10W
Power dissipation at 10A output, 55VDC supply	40W

THERMAL REQUIREMENTS

Storage temperature range	-30 to +85°C
Operating temperature range	0 to 70°C baseplate temperature

MECHANICAL

Size	3.27 x 4.75 x 1.28 in. (83 x 121 x 33mm)
Weight	0.52 lb (0.24 kg.)

CONNECTORS

Power & motor	Weidmuller: BL-125946; Phoenix: MSTB 2.5/5-ST-5.08
Signal	Molex: 22-01-3147 housing with 08-50-0114 pins

APPLICATION INFORMATION

To use the model 403 set up the internal header with the components that configure the transconductance, current limits, and load inductance. Current-limits and load inductance set up the amplifier for your particular motor, and the transconductance defines the amplifiers overall response in amps / volt that is required by your system.

SETUP BASICS

1. Set RH1 and CH2 for motor load inductance (see following section).
2. Set RH3, 4, & 5 if current limits below standard values is required.
3. Set transconductance with RH6,7.
4. Ground the /Enable (/Enable Pol open), /Pos Enable, and /Neg Enable inputs to signal ground.
5. Connect J1-4,5 to a transformer-isolated source of DC power, 18-55V.

COMPONENT HEADER SETTINGS

Use the tables provided to select values for your load and system. We recommend that you use these values as starting points, adjusting them later based on tests of the amplifier in your application.

1. LOAD INDUCTANCE (RH1,CH2)

Maximizes the bandwidth with your motor and supply voltage. First replace CH2 with a jumper (short). Adjust the value of RH1 using a step of 1A or less so as not to experience large signal slew-rate limiting. Select RH1 for the best transient response (lowest risetime with minimal overshoot). Once RH1 has been set. choose the smallest value of CH2 that does not cause additional overshoot or degradation of the step response.

2. CURRENT LIMITS (RH3, 4, & 5)

The amplifier operates at the 5A continuous, 10A peak limits as delivered. To reduce the limit settings, choose values from the tables as starting points, and test with your motor to determine final values. Limit action can be seen on current monitor when output current no longer changes in response to input signals. Separate control over peak, continuous, and peak time limits provides protection for motors, while permitting higher currents for acceleration.

3. TRANSCONDUCTANCE (RH6,7)

The transconductance of the 403 is the ratio of output current to input voltage. It is equal to $10\text{k}\Omega/\text{RH6}$ (Amps / Volt). RH6, and RH7 should be the same value and should be 1% tolerance metal film type for good common-mode noise rejection.

4. ENABLE INPUTS

/Enable, /Pos Enable and /Neg enable must all be grounded for the amplifier to operate. If your system outputs +5V to turn the amplifier on, then wire /Enable Pol to ground. This will invert the /Enable input only. /Pos and /Neg enable must still be grounded to run.

5. GROUNDING & POWER SUPPLIES

Power ground and signal ground are common (internally connected) in this amplifier. These grounds are isolated from the amplifier case which can then be grounded for best shielding while not affecting the power circuits. Currents flowing in the power supply connections will create noise that can appear on the amplifier grounds. This noise will be rejected by the differential amplifier at the reference input, but will appear at the digital inputs. While these are filtered, the lowest noise system will result when the power-supply capacitor is left floating, and each amplifier is grounded at its power ground terminal. In multiple amplifier configurations, always use separate cables to each amplifier, twisting these together for lowest noise emission. Twisting motor leads will also reduce radiated noise from PWM outputs. If amplifiers are more than 1m. from power supply capacitor, use a small (200-500 μF .) capacitor across power inputs for local bypassing.

ENABLE INPUT POLARITY

The active level of the /Enable input *only* can be changed from ground enables to +5V enables by grounding the / Enable Pol pin (J2-7). This permits use with control cards that output +5V to turn-on the amplifier, and ground to inhibit it. Note that this does not affect the /Pos and /Neg enable inputs. These must be grounded to enable output currents in their respective polarities (+5V or open will inhibit pos/neg currents).

NORMAL OUTPUT

This is a +5V logic level signal that will be HI (+5V) when the amplifier is operating normally, and will go LO (ground) if there is a fault condition, or if the amplifier is disabled (inhibited).

It can source or sink 2mA, which can then be used to drive an optocoupler, if isolation for the signal is desired.

The illustrations below show an optocoupler used to make either a LO or HI active Normal signal.

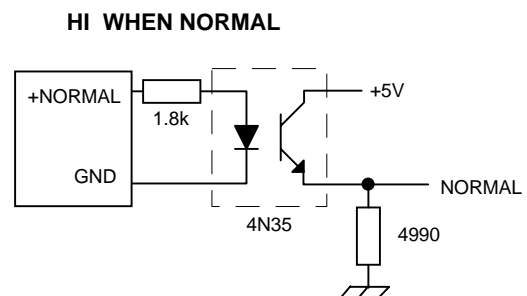
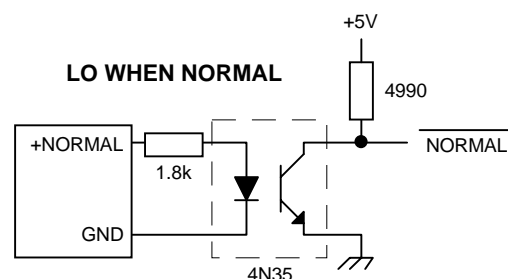

Model 403 DC Brush Servo Amplifier

If a FAULT signal is required, then reversing the connections to the input led of the optocoupler will provide it, as shown below.

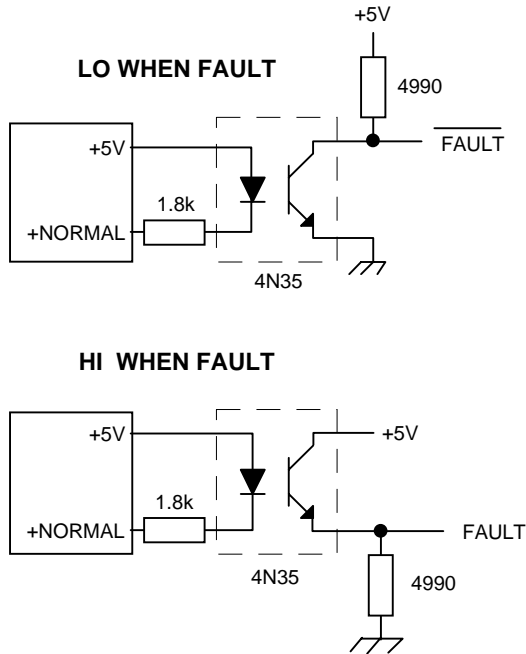

OUTLINE DIMENSIONS

Dimensions in inches (mm.)

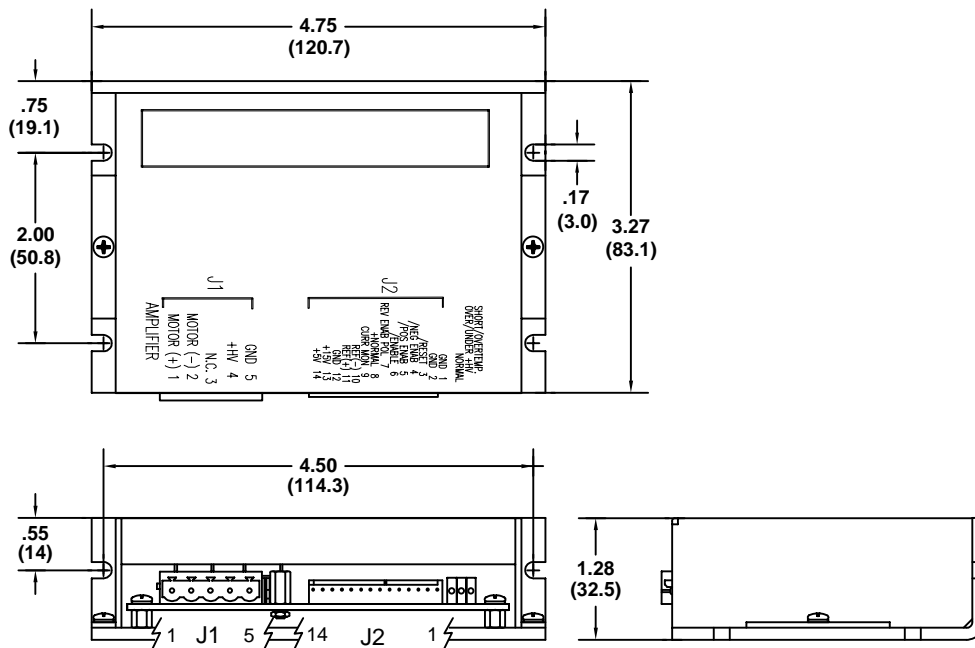

WEIGHT 0.52 lb (0.24 kg)

MATING CONNECTORS

J1: Power & motor
J2: Signal

Weidmuller: BL-125946; Phoenix: MSTB 2.5/5-ST-5.08
Molex: 22-01-3147 housing with 08-50-0114 pins

ORDERING GUIDE

Model 403	5A Continuous, 10A Peak, +18 to +55V DC Servoamplifier
-----------	--

OTHER DC SERVOAMPLIFIERS

Model 405 Same power output as 403. Adds encoder tachometer feature for velocity loop operation.

400 Series Six models covering +24 to +225VDC operation, 5-15A continuous, 10-30A peak.